

UPPER '0' SIDE CLEARANCE
BRACKET - P/N# 33163-1

SEE NOTE

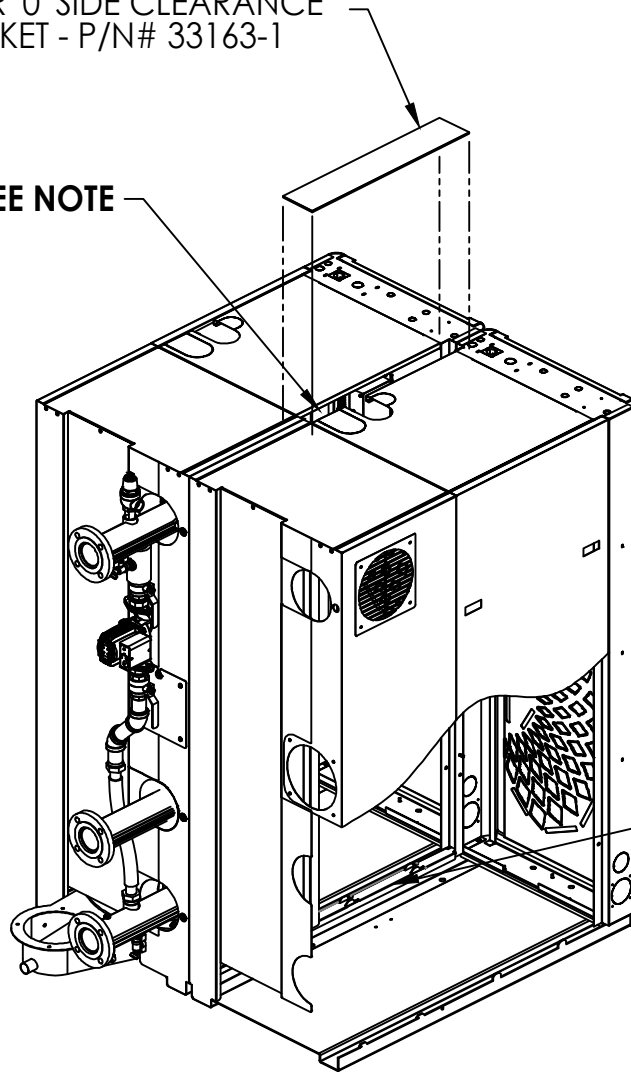

NOTE: BEFORE PLACING THE 2 UNITS SIDE-BY-SIDE
TOGETHER, REMOVE THE SIDE PANELS IN
BETWEEN FIRST.

LOWER '0' SIDE CLEARANCE
BRACKET - P/N# 33164

REAR VIEW

PARTS NOT SHOWN WERE REMOVED FOR CLARITY



A WATTS Brand

100 ORITANI DRIVE, BLAUVELT, NY 10913
aerco.com

ZERO SIDE CLEARANCE KIT
INSTALLATION

DWN.BY K.S. DATE 032425
SCALE NTS
REV.BY _____ DATE _____

SD-A-1367

REV.
A