

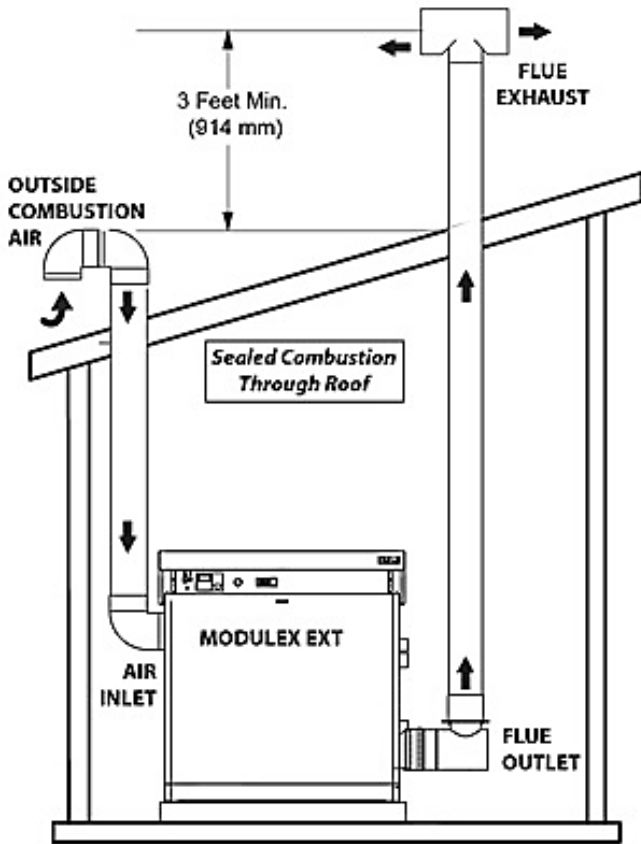

TECHNICAL APPLICATION GUIDE

Venting & Combustion Air Guide

Modulux EXT Series Boilers
Modulating Condensing Hot Water Boilers



Modulux EXT

APPLIES TO THE FOLLOWING LIGHT COMMERCIAL MODELS

- MLX EXT 321
- MLX EXT 450 / MLX EXT 481
- MLX EXT 600 / MLX EXT 641
- MLX EXT 800 / MLX EXT 802
- MLX EXT 962
- MLX EXT 1100 / MLX EXT 1123

COMMERCIAL MODELS

- MLX EXT 1500 / MLX EXT 1530
- MLX EXT 1912
- MLX EXT 2295 / MLX EXT 2300
- MLX EXT 2600 / MLX EXT 2677
- MLX EXT 3000 / MLX EXT 3060

Latest Update: 09/25/2017

Technical Support
1-800-526-0288
 (Mon-Fri, 8am-5pm EST)
www.aerco.com



DISCLAIMER:

The information contained in this manual is subject to change without notice from AERCO International, Inc. AERCO makes no warranty of any kind with respect to this material, including, but not limited to, implied warranties of merchantability and fitness for a particular application. AERCO International is not liable for errors appearing in this manual, nor for incidental or consequential damages occurring in connection with the furnishing, performance, or use of these materials

TABLE OF CONTENTS:

CHAPTER 1: CODES, SAFETY, AND VENTING SYSTEMS 3

1.1. APPLICABLE FEDERAL CODES3

1.2. GAS VENT CATAGORIES.....4

1.3. CERTIFIED VENTING MATERIALS FOR FLUE PIPE SYSTEMS4

1.3.1. OPTION 1: AL29-4C Stainless Steel5

1.3.2. OPTION 2: VP1738A Stainless Steel5

1.3.3. OPTION 3: Polypropylene5

1.3.4. OPTION 4: PVC/CPVC5

1.4. FACTORY SUPPLIED INLET AND VENT COMPONENTS 6

1.4.1. Exhaust Manifold Assembly (Supplied)6

1.4.2. European-to-American Flue Adaptor (Supplied)6

1.4.3. Flue Exhaust Piping Starter Pieces7

1.4.4. Air Intake Connector (Supplied).....8

CHAPTER 2: COMBUSTION AIR SYSTEM 9

2.1. COMBUSTION AIR REQUIREMENTS.....9

2.2. COMBUSTION AIR PIPE SIZING 12

2.3. COMMON COMBUSTION AIR PIPE SIZING..... 13

CHAPTER 3: VENT SYSTEM..... 16

3.1. VENT INSTALLATION 16

3.2. INSTALLATION PROCEDURE FOR VENTING SYSTEM THROUGH WALLS..... 22

3.3. INSTALLATION PROCEDURE FOR VERTICAL VENTING..... 24

3.4. VENT PIPING SIZE..... 25

3.5. COMMON VENT PIPING SIZE 26

CHAPTER 1: CODES, SAFETY, AND VENTING SYSTEMS

1.1. APPLICABLE FEDERAL CODES

<u>United States:</u>	
NFPA 54/ANSI Z223.1:	National Fuel Gas Code
NFPA/ANSI 211:	Chimneys, Fireplaces, Vents and Solid Fuel Burning Appliances
<u>Canada:</u>	
CAN1-B149.1:	Installation Codes for Gas-Burning Equipment
B149.2:	Installation Codes for Gas-Burning Equipment

The above listed codes contain information for gas vented appliances requiring Category II, III and IV, vent sizing, location, air space clearances to combustibles and safe installation practices. The gas vent installer must be familiar with the above codes, as well as Local Codes and Regulations.

WARNING!

All installations of boilers and venting should be done only by qualified venting systems personnel and in accordance with the manufacturer's recommendations. Installing or venting a boiler or any other gas appliance with improper methods or materials may result in serious injury or death due to fire or to asphyxiation from poisonous gases (carbon monoxide is odorless and invisible).

WARNING!

- For correct installation of vent system, read all of these instructions and refer to the vent pipe manufacturer's instructions.
- Failure to use the venting system described in this document will void the manufacturer's warranty and may result in rapid deterioration of the venting system, creating a potential health hazard.
- Faulty vent installation can allow toxic fumes to be released into living areas. This may cause serious bodily injury or property damage. Improper assembly may also affect vent performance.
- Install separate vents for forced exhaust appliances and natural draft appliances. A common vent between natural draft and forced exhaust appliances may cause toxic gases to exhaust through the natural draft appliance rather than to outside air. Breathing exhaust gases will cause serious personal injury or death.

1.2. GAS VENT CATAGORIES

WARNING!

The Modulex boiler is approved for a Category IV vent configuration as well as for sealed combustion installations. Make provisions for combustion and ventilation air in accordance with Section 5.3, (Air for Combustion and Ventilation) of the National Fuel Gas Code - ANSI Z223.1, or Sections 7.2, 7.3, or 7.4 of CAN/CGA B149, Installation Codes, or applicable provisions of the local building codes.

Federal Codes have categorized gas appliances by the vented flue gas pressure and temperature:

- **Category I**, being a gas appliance that operates with a *non-positive* vent (or natural drafted vent) connector with a flue gas pressure and temperature *at least* 140°F (60°C) above its dew point.
- **Category II**, being a gas appliance that operates with a *non-positive* vent (or natural drafted vent) connector with a flue gas pressure and temperature *less than* 140°F (60°C) above its dew point.
- **Category III**, being a gas appliance that operates with a *positive* vent (fan forced vent) connector with a flue gas pressure and temperature *at least* 140°F (60°C) above its dew point.
- **Category IV**, being a gas appliance that operates with a *positive* vent (fan forced vent) connector with a flue gas pressure and temperature *less than* 140°F (60°C) above its dew point.
- **Direct Vent**, a gas appliance is constructed and installed so that all air for combustion is derived directly from the outdoors and all flue gases are discharged to the outdoors.

1.3. CERTIFIED VENTING MATERIALS FOR FLUE PIPE SYSTEMS

Acceptable materials and manufacturers for flue vent pipe systems are listed below in Option #1 – Option #4.

WARNING!

The Vent Pipe Systems below are used for venting gas burning Category IV appliances. Do not use these vent pipe systems for venting appliances burning fuels such as wood, coal, oil or kerosene.

Maintain clearances from combustible construction for boiler, vent connector, and steam and hot-water pipes.

Do not use these vent pipe systems for incinerators of any kind.

Do not vent Modulex systems using the same vent piping as being used for either Benchmark or KC boilers.

1.3.1. OPTION 1: AL29-4C Stainless Steel

- Security Chimneys International, Secure Seal, SS, SSD, and SSID (available through AERCO)
- Flex-L International Inc., StaR 34 Vent
- Heat-Fab Inc., Saf-T Vent
- Protech System Inc., Fas N Seal Vent
- Metal-Fab Inc., Corr/Guard Vent
- Z-Flex Z-Vent

1.3.2. OPTION 2: VP1738A Stainless Steel

- Van-Packer Company, Inc., Model CS Special Gas Vent

1.3.3. OPTION 3: Polypropylene

- DuraVent, Polypro Commercial (Available through AERCO)
- Centrotherm ECO Systems, InnoFlue Single Wall Commercial

1.3.4. OPTION 4: PVC/CPVC

Use Schedule 40 or thicker, Single-Wall, Uninsulated Pipes

When using Non-Metallic (Plastic) vent systems for Canadian installations, per CSA B149.1, use vent systems that are certified to the Standard for Type BH Gas Venting Systems, ULC-S636. The plastic components, primers and glues of the certified vent system must be from a single system manufacturer and not inter-mixed with other manufacturers vent system parts.

PVC

- ASTM F891
- ASTM D2665
- ASTM D1785
- ASTM D2241

CPVC

- ASTM D2846
- ASTM F441
- ASTM F442

1.4. FACTORY SUPPLIED INLET AND VENT COMPONENTS

For installation flexibility, venting connectors are provided for left hand, right hand, and rear connections. Basic drawings of the connection components and optional assemblies are shown in Figures 1 through 4.

1.4.1. Exhaust Manifold Assembly (Supplied)

The exhaust manifold and necessary parts are supplied with the unit, and can be positioned on the right, left, or rear of the unit. Two flue exhaust opening covers with gaskets are used to cover the unused manifold openings. Assembly of the exhaust manifold is described in detail in Chapter 3. See Figure 1 for image of the exhaust manifold parts.

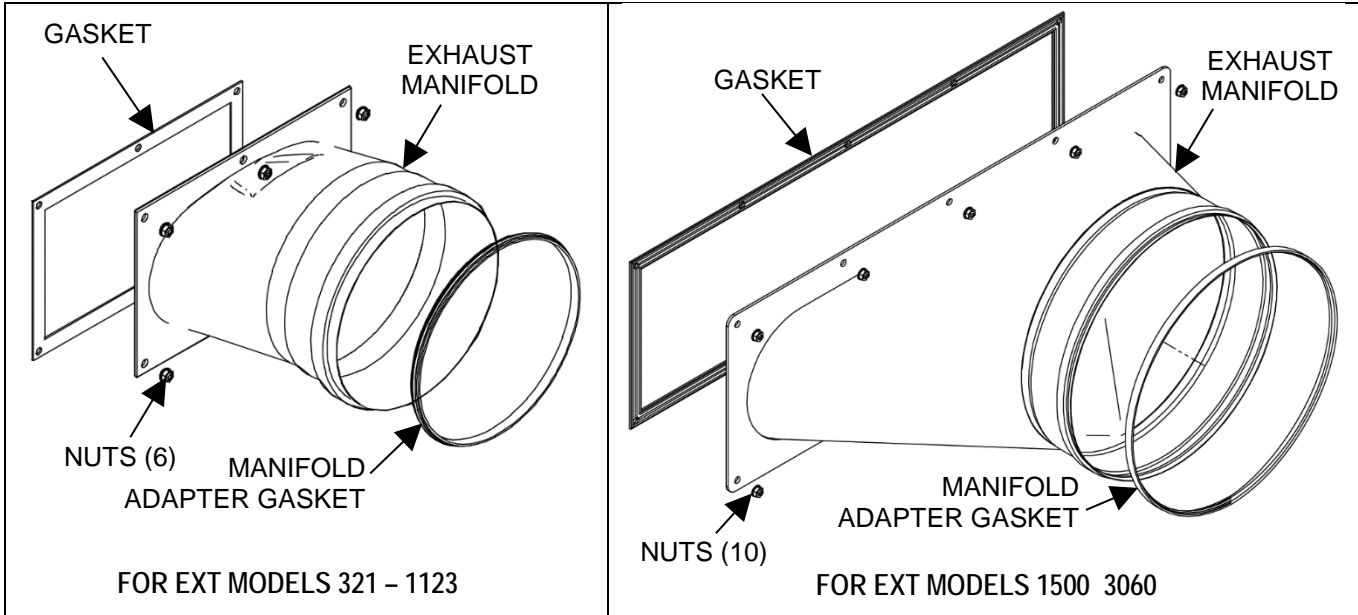

Figure 1: Exhaust Manifold Components for Exhaust Outlet (Supplied)

1.4.2. European-to-American Flue Adaptor (Supplied)

The exhaust manifold supplied with the unit requires the use of an adaptor to connect to American flue systems. This adaptor comes standard with the unit, and is pictured in Figure 2. Assembly of this adaptor is described in detail in Chapter 3.

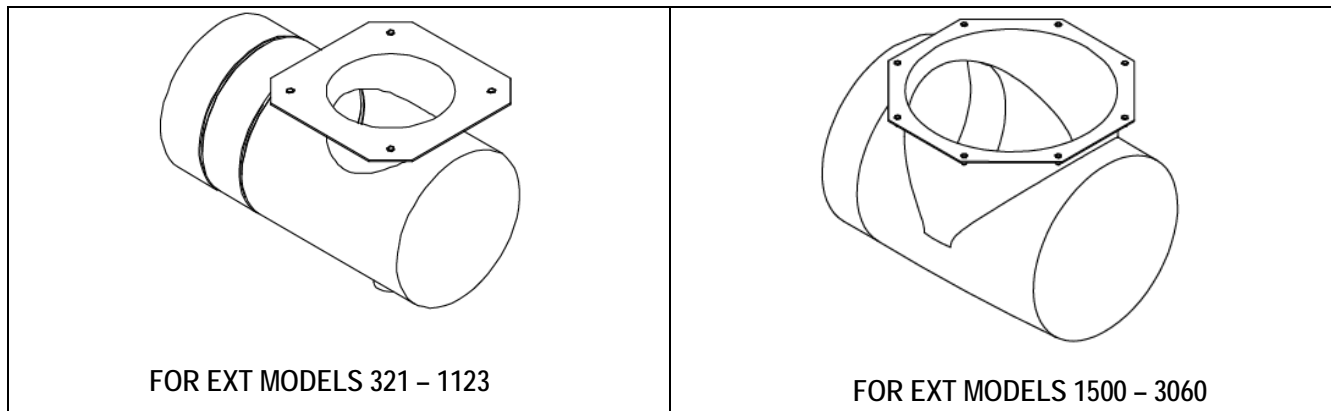

Figure 2: European-to-American Flue Adaptor (Supplied)

1.4.3. Flue Exhaust Piping Starter Pieces

Table 1 lists the exhaust vent adaptors available for each Modulex EXT model. Instructions for assembling the vent adaptors are in Chapter 3.

TABLE 1: EXT Vent Adaptors			
BOILER MODELS	DIAMETER	MATERIAL	KIT PART NUMBER
EXT 321, 450, 481	4"	Stainless Steel	Contact vent manufacturer directly
		Polypropylene	P/N 39006-1 (for Duravent PolyPro. For other brands, contact manufacturer directly.
		PVC	P/N 49051 (included)
EXT 600 – 1123	6"	Stainless Steel	Contact vent manufacturer directly
		Polypropylene	P/N 39006-2 (for Duravent PolyPro. For other brands, contact manufacturer directly.
		PVC	P/N 49050 (included)
EXT 1500, 1530, 1912	10"	Stainless	Contact vent manufacturer
		Polypropylene	Contact vent manufacturer
		PVC *	58115-1
EXT 2295 – 3060	12"	Stainless	Contact vent manufacturer
		Polypropylene	Contact vent manufacturer
		PVC *	58115-2

* While the MLX EXT 1500 – 3060 are approved for use with PVC venting, this option can be extremely heavy and expensive. AERCO strongly recommends Polypropylene or Stainless Steel venting for these models.

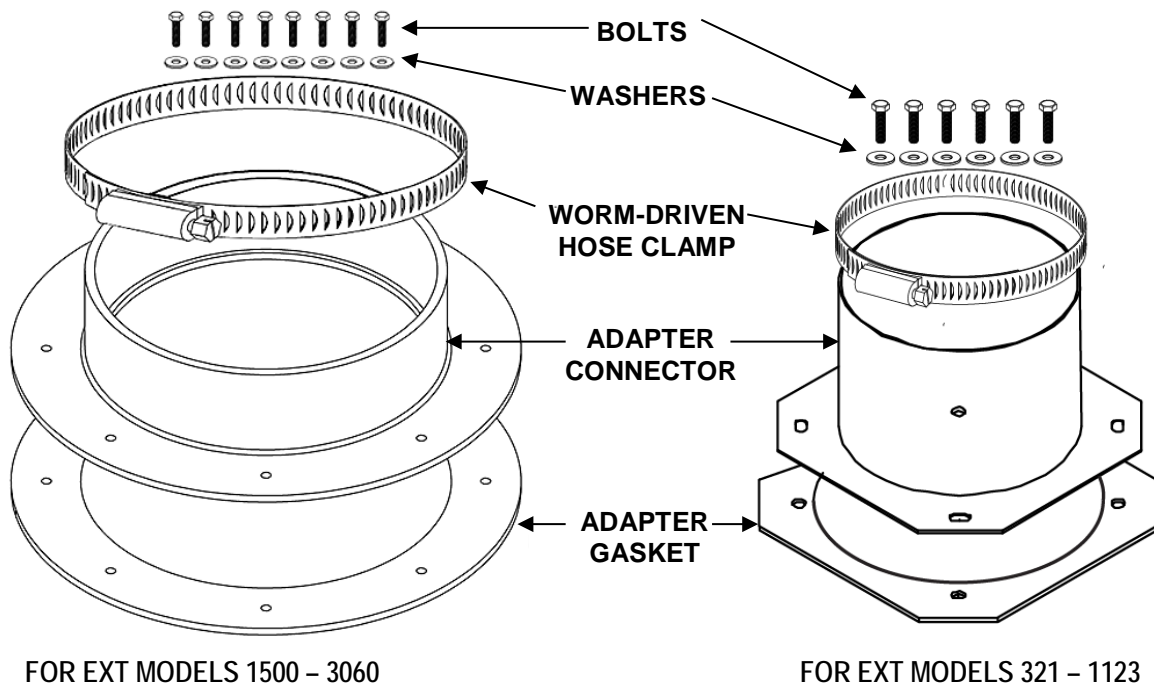

Figure 3: Flue Piping Starter Pieces

1.4.4. Air Intake Connector (Supplied)

Air is drawn into the EXT through the air inlet on the left side of the unit (Figure 4). A connector is included installed and ready to use for connecting the appropriate air intake piping for EXT 321–1123/450–1100. For EXT 1530–3060/1500–3000, the combustion air intake adapter is shipped loose. This adapter is designed for spiral ducting only. For PVC ducting, order either P/N 58115-1 or 58115-2 as per Table 1.

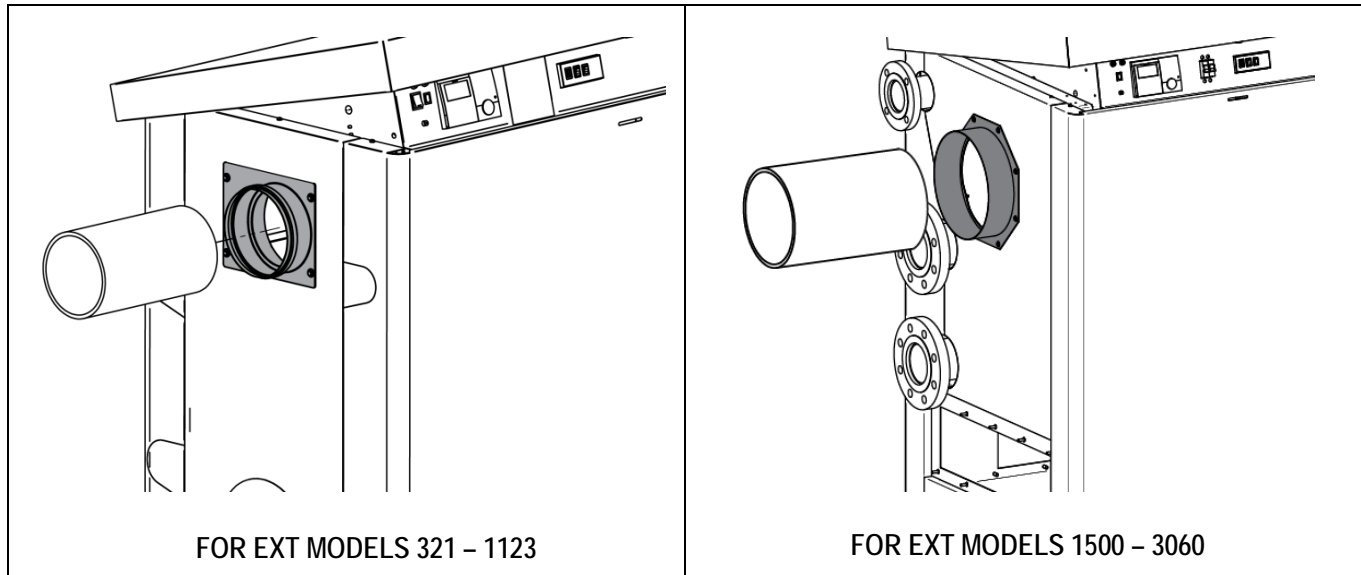

Figure 4: Air Intake Connection

NOTE:

See Chapter 3 for instructions for assembling the flue piping, including the exhaust manifold, Euro-to-USA Adaptor, and Diameter Reduction Kits.

When using sealed combustion, observe the following requirements:

- Sealed combustion is only available on the left of the unit only.
- If using side-by-side minimum installation clearances, the center facing air inlet is not available. See “Multi-Unit Installation Clearances (SD-A-968)” for further details.

Please note the following:

- EXT Models 321 – 1123 are set up for PVC inlet piping.
- EXT Models 1500 – 3060 come with an air intake adaptor for spiral ducting.

CHAPTER 2: COMBUSTION AIR SYSTEM

WARNING!

Air openings to combustion area must not be obstructed. Using Table 2, air openings may be specified so that adequate combustion air can be maintained.

2.1. COMBUSTION AIR REQUIREMENTS

WARNING!

- Non-Motorized louvers and grilles must be fixed in an open position.
- Minimum screens mesh size shall not be smaller than 1/4" (inch) mesh.

Table 2, below, shows the minimum required air openings in square inches (square centimeters) freely communicating with the outdoors for boiler room combustion and ventilation air for each boiler. For multiple boiler installations, sum the openings for the specific boiler sizes.

TABLE 2: Min. Required Air Openings Freely Communicating With the Outdoors for Boiler Room Combustion & Ventilation Air			
MODEL	TWO SEALED COMBUSTION OR VERTICAL DUCTS <u>EACH</u> HAVING AN OPENING IN SQ. IN. (SQ.CM) OF:	TWO HORIZONTAL DUCTS <u>EACH</u> HAVING AN OPENING IN SQUARE INCHES OF:	SINGLE PERMANENT OPENING
EXT 321	80 in ² (516 cm ²)	161 in ² (1039 cm ²)	107 in ² (690 cm ²)
EXT 481/450	120 in ² (774 cm ²)	241 in ² (1555 cm ²)	160 in ² (1032 cm ²)
EXT 641/600	160 in ² (1032 cm ²)	321 in ² (2071 cm ²)	214 in ² (1381 cm ²)
EXT 802/800	201 in ² (1297 cm ²)	401 in ² (2587 cm ²)	267 in ² (1723 cm ²)
EXT 962	241 in ² (1655 cm ²)	481 in ² (3103 cm ²)	321 in ² (2071 cm ²)
EXT 1123/1100	281 in ² (1813 cm ²)	562 in ² (3626 cm ²)	374 in ² (2413 cm ²)
EXT 1530/1500	383 in ² (2471 cm ²)	765 in ² (4935 cm ²)	510 in ² (3290 cm ²)
EXT 1912	478 in ² (3084 cm ²)	956 in ² (6168 cm ²)	637 in ² (4110 cm ²)
EXT 2295/2300	574 in ² (3703 cm ²)	1148 in ² (7406 cm ²)	765 in ² (4935 cm ²)
EXT 2677/2600	669 in ² (4316 cm ²)	1339 in ² (8639 cm ²)	892 in ² (5755 cm ²)
EXT 3060/3000	765 in ² (4936 cm ²)	1530 in ² (9871 cm ²)	1020 in ² (6581 cm ²)

1. The combustion air must be free of chlorine, halogenated hydrocarbons or other chemicals that can become hazardous when used in gas-fired equipment. Common sources of these compounds are swimming pools, degreasing compounds, plastic processing, and refrigerants. Whenever the environment contains these types of chemicals, combustion air **MUST** be supplied from a clean area outdoors for the protection and longevity of the equipment and warranty validation.
2. Ventilation of the boiler room must be adequate enough to provide sufficient air to properly support combustion.

3. When combustion air is brought from outside the building and the boiler room is provided with two permanent openings, one shall commence 12 inches from the top and the other shall commence within 12 inches from the bottom of the room (see Figure 5). The openings shall communicate directly, or by ducts, freely with the outdoors. One of the following methods must be made to provide adequate air for ventilation and combustion.

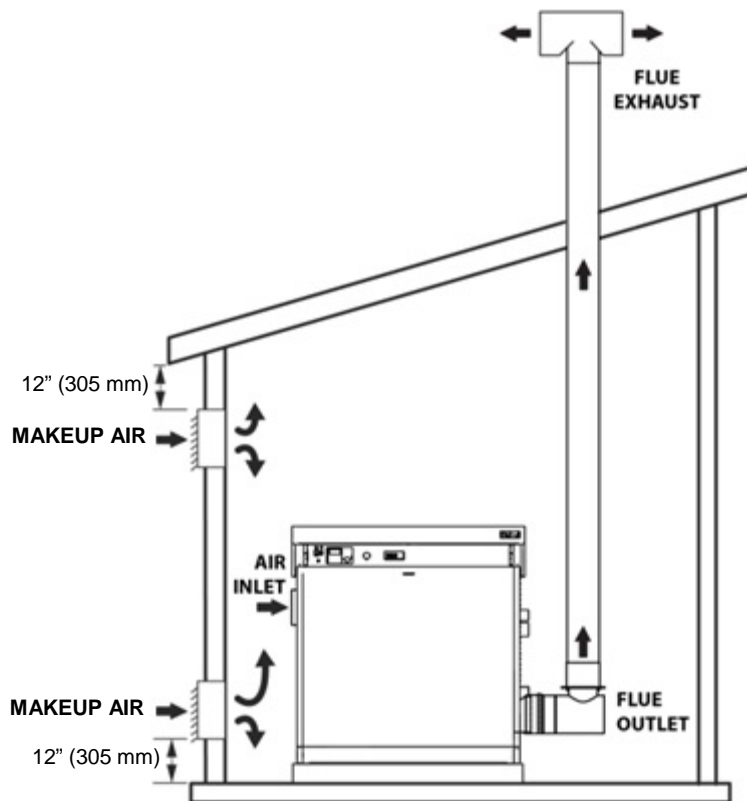

Figure 5: Combustion-Air Makeup-Air Vent Locations

- When directly communicating with the outdoors, each opening shall have a minimum free area of 1 square inch per 4,000 BTU per hour of total input rating of all equipment in the room.
 - When communicating with the outdoors by means of vertical ducts, each opening shall have a minimum free area of 1 square inch per 4,000 BTU per total input rating of all appliances in the room.
 - If horizontal ducts are used, each opening and duct shall have a minimum free area of 1 square inch per 2,000 BTU per hour of total input rating of all appliances in the room.
4. When calculating free area using louvers and grilles, the required size of the openings for combustion, ventilation, and dilution air shall be based on the total free area of each opening.
 5. If the free area through a designed louver or grille is known, it shall be used in calculating the size of the opening required to provide the free area specified.
 6. If the louver and grille design free areas are not known, the following will be assumed for wooden louvers a 25 percent free area, and for metal louvers and grilles a 75 percent free area opening.

7. When terminating the combustion air through the roof:
 - a) Combustion air inlet must be 3 ft. below any vent outlet within 10 ft. See Figures 6 and 7.
 - b) Combustion air inlet must also face away from the vent outlet. See Figure 6.

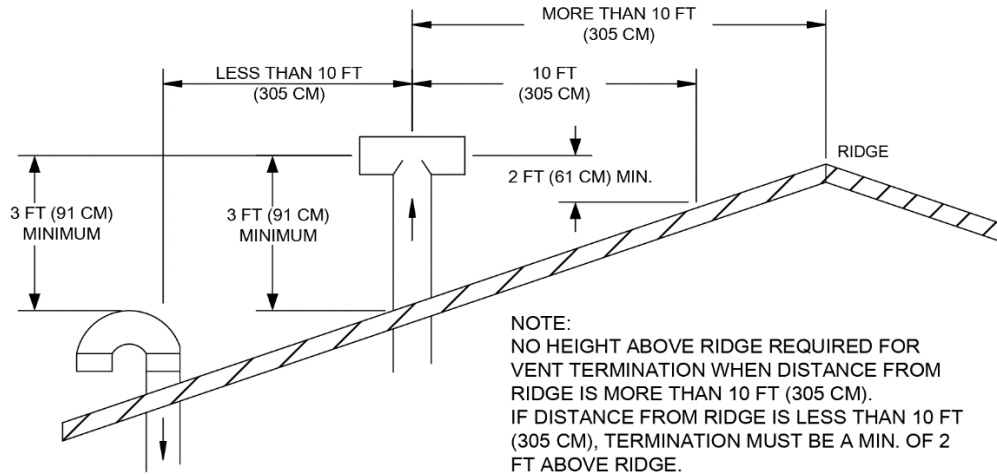

Figure 6: Combustion Air Roof Termination Locations

8. All inlet air ducts must be sealed air tight.
9. When using sealed combustion, the combustion air inlet and vent outlet must be located on the same surface (same wall, roof, etc.). See Figures 7. This is required so that equal pressure zones are acting on both the air inlet and vent outlet. This makes the installation a balanced vent system, which helps maintain stable combustion characteristics.
10. For outdoor installations, a downward facing 90° elbow should be added to the inlet air connection and covered with a bird screen. See Figure 8.

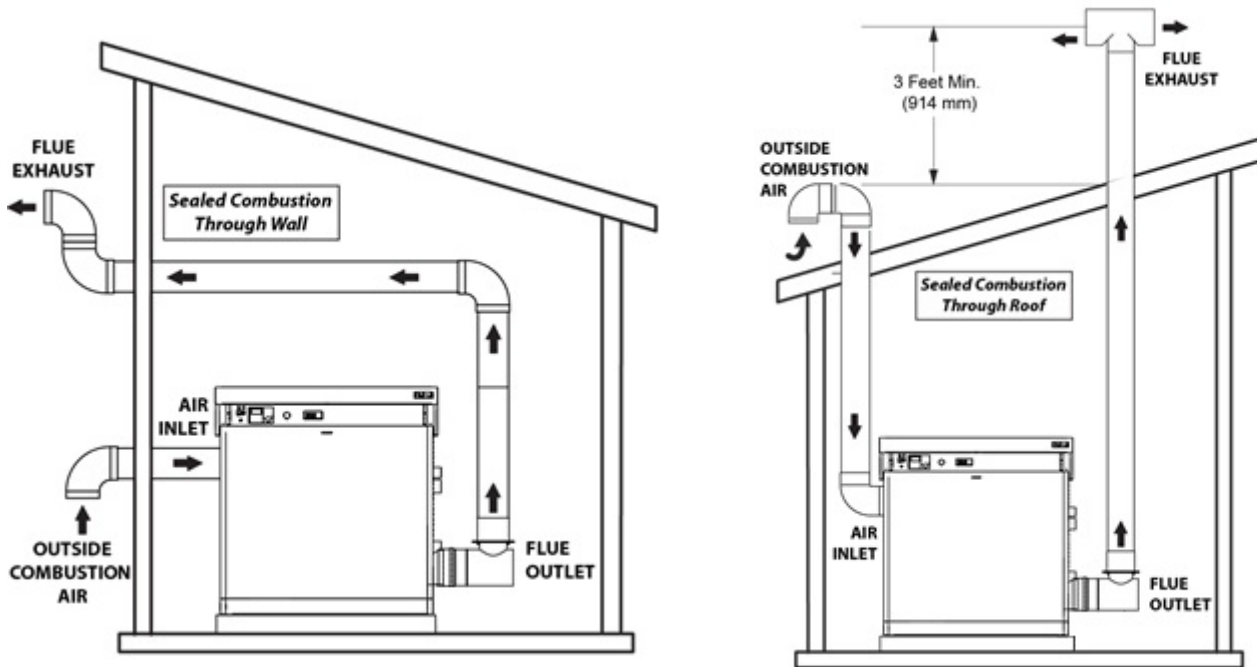

Figure 7: Sealed Combustion Air Inlet and Vent Outlet Locations (Wall & Roof)

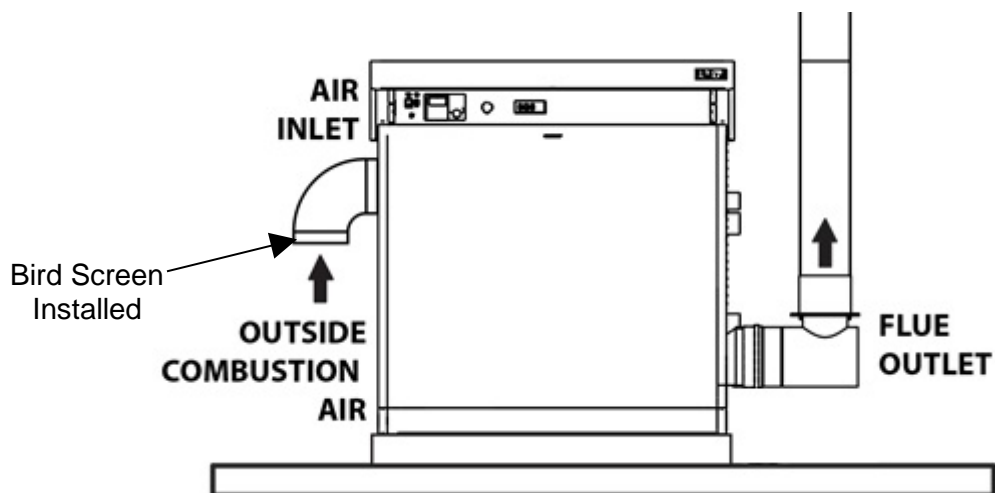

Figure 8: Outdoor Installation Air Inlet and Vent Outlet Locations

11. For outdoor installations, an outdoor venting kit is available through AERCO. Please contact your local representative for further details.

2.2. COMBUSTION AIR PIPE SIZING

The maximum length is the combined length of straight horizontal and vertical runs, and the equivalent straight length of fittings. The required lengths for each boiler are shown in Table 3, below.

TABLE 3: Maximum Combustion Air Run Lengths					
MODEL NO.	PIPE DIAM.	EQUIVALENT PIPE LENGTHS EXAMPLES			MAXIMUM LENGTH EQUIVALENT FT (M)
		Sharp 90° Elbow Equiv. Ft (m)	Sweep 90° Elbow Equiv. Ft (m)	45° Elbow Equiv. Ft (m)	
EXT 321 EXT 481/450 EXT 641/600	4" (102 mm)	10 ft. (3.05 m)	5 ft. (1.5 m)	5 ft. (1.5 m)	100 ft. (30.5 m)
EXT 802/800 EXT 962 EXT 1123/1100	6" (152 mm)	10 ft. (3.05 m)	N/A	5 ft. (1.5 m)	100 ft. (30.5 m)
EXT 1530/1500 EXT 1912	10" (254 mm)	10 ft. (3.05 m)	N/A	5 ft. (1.5 m)	100 ft. (30.5 m)
EXT 2295/2300 EXT 2677/2600 EXT 3060/3000	12" (305 mm)	10 ft. (3.05 m)	N/A	5 ft. (1.5 m)	100 ft. (30.5 m)

The maximum pressure drop of the vent is also 100 equivalent feet (30.5 m). See Section 3.4. Note that this does **NOT** mean the allowed combined pressure drop between the vent and combustion air is 200 equivalent feet (61 m). That is, the vent cannot go above 100 equivalent feet (30.5 m), even if the combustion air is less than 100 equivalent feet, and vice versa.

EXAMPLES:

1. A 40 foot length of combustion air pipe and 1 sharp 90° elbow plus two termination 90° elbows add up to 40 ft. + 10 ft. + (2 x 10 ft.) = 70 equivalent ft. (21.3 m).
2. A 30 foot length of combustion air pipe and 2 sharp 90° elbows plus two termination 90° elbows add up to 30 ft. + (2 x 10 ft.) + (2 x 10 ft.) = 70 equivalent ft. (21.3 m).

2.3. COMMON COMBUSTION AIR PIPE SIZING

Refer to Figures 9 and 10 for typical common combustion air inlet installation. The maximum length is the sum of the equivalent straight length of horizontal runs, vertical runs, and fittings of the individual combustion air connector and the common combustion air pipe. The required diameter lengths for a given Modulex total BTU/hr. Input are shown in Table 4, below.

TABLE 4: Typical Common Combustion Air Run Lengths

TOTAL BTU/HR INPUT (UP TO AND INCLUDING)	COMMON VENT DIAMETER	EQUIVALENT COMMON VENT LENGTHS EXAMPLES				MAXIMUM LENGTH → INDIVIDUAL CONNECTOR PLUS COMMON VENT EQUIVALENT FT (M)
		Sharp 90° Elbow Equiv. Ft (m)	Sweep 90° Elbow Equiv. Ft (m)	45° Elbow Equiv. Ft (m)	WYE or Termination Tee or Vent Cap Equiv. Ft (m)	
606,000	4" (102 mm)	10 ft. (3.05 m)	5 ft. (1.5 m)	5 ft. (1.5 m)	5 ft. (1.5 m)	100 ft. (30.5 m)
1,284,000	6" (152 mm)	10 ft. (3.05 m)	N/A	5 ft. (1.5 m)	5 ft. (1.5 m)	100 ft. (30.5 m)
2,407,500	8" (203 mm)	10 ft. (3.05 m)	N/A	5 ft. (1.5 m)	5 ft. (1.5 m)	100 ft. (30.5 m)
3,825,000	10" (254 mm)	10 ft. (3.05 m)	N/A	5 ft. (1.5 m)	5 ft. (1.5 m)	100 ft. (30.5 m)
5,355,000	12" (305 mm)	10 ft. (3.05 m)	N/A	5 ft. (1.5 m)	5 ft. (1.5 m)	100 ft. (30.5 m)
6,885,000	14" (358 mm)	10 ft. (3.05 m)	N/A	5 ft. (1.5 m)	5 ft. (1.5 m)	100 ft. (30.5 m)
9,180,000	16" (407 mm)	10 ft. (3.05 m)	N/A	5 ft. (1.5 m)	5 ft. (1.5 m)	100 ft. (30.5 m)

The chart above shows equivalent pipe lengths of the fittings for the common combustion air pipe. See section 2.2 for equivalent lengths for fittings for the individual boiler connector.

The maximum equivalent length shown is the sum of the equivalent length of the longest individual connector plus the equivalent length of the common combustion air pipe. If the maximum equivalent length exceeds 100 equivalent feet, contact your AERCO sales representative or AERCO International for design assistance and approval.

It is important to use a WYE as a means to connect the individual combustion air pipe into the common combustion air pipe. This will ensure the least amount of pressure drop. Do NOT use a TEE, 90°, or 45° elbow.

The maximum pressure drop of the vent is also 100 equivalent feet (30.5 m). Note that this does NOT mean that the allowed combined pressure drop between the vent and combustion air is 200 equivalent feet (61 m). That is, the vent cannot go above 100 equivalent feet (30.5 m), even if the combustion air is less than 100 equivalent feet, and vice versa.

EXAMPLES:

The combustion air system of two EXT 1123/1100 (2 x 1,123,000 BTU/hr. = 2,246,000 BTU/hr.) consists of 30 foot length of common combustion air pipe and 3 sharp 90° elbows. The termination includes two (2) 90° elbows. Each individual combustion air connector consists of 10 ft. straight run and one WYE.

Common Combustion air pipe: 30 ft. + (3 x 10ft) + (2 x 10ft) = 80 equivalent ft. (24.3 m)

Individual combustion air connector: 10 ft. + 5 ft. = 15 equivalent ft. (4.6 m)

Total Combustion air equivalent length: 80 ft. + 15 ft. = 95 (29.0 m)

95 equivalent ft. is LESS than 100 equivalent feet: OK to use 8" Common air intake piping and 6" individual connectors.

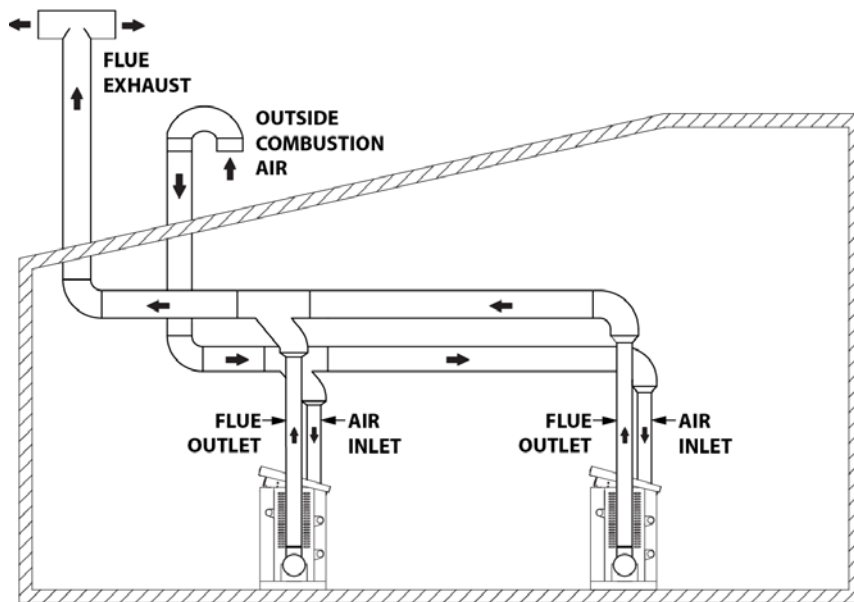

Figure 9: Typical Common Combustion Air Inlet installation Through Roof

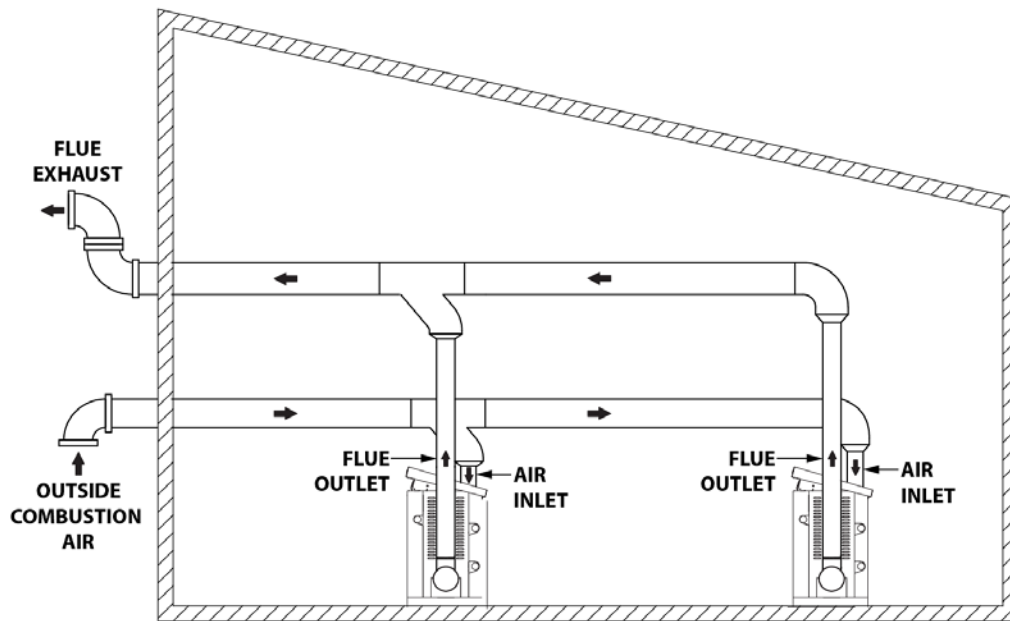

Figure 10: Typical Common Combustion Air Inlet installation Through Wall

CHAPTER 3: VENT SYSTEM

Correct boiler venting is crucial for proper operation. Being a condensing boiler, combustion gases are discharged at a very low temperature. It is therefore necessary for the venting system to be impermeable to combustion products and condensate and to be made of corrosion resistant materials. Typical Category IV venting and sealed combustion illustrations are shown in Figure 5 through 9. The various funnel joints shall be well sealed and/or equipped with suitable gaskets, in order to avoid any condensate drain and/or air intake. Ensure that the boiler vent's section and height conform to national and local regulations (see Section 1.1 in this guide).

For boilers designed for connection to gas vents or chimneys, vent installations shall be in accordance with Part 7, Venting of Equipment, of the National Fuel Gas Code, ANSI Z223.1, or Section 7, Venting Systems and Air Supply for Appliances, of the CAN/CGA B149, Installation Codes, or applicable provisions of the local building codes.

The vent system for the Modulex boilers must be installed in accordance with AERCO's installation

CAUTION!

For Category IV Boilers, the vents must be installed to prevent accumulation of condensate, and have means provided for drainage of condensate.

3.1. VENT INSTALLATION

- The boilers covered in this section are design-certified as Category IV for venting, only when they are installed with manufacturer specified vent system components and installation practices.
- Install supplied vent pipe starter piece at the boiler vent connector and work toward the vent or rain cap. To attach the exhaust connector to the flue collector, use the screws and the gasket supplied inside the plastic bag. Use a 14mm socket wrench with at least a 12 inch (300 mm) extension. See Figures 11 and 12.
- Vent pipe fittings and connectors serving appliances vented by natural draft shall not be connected into any portion of mechanical draft systems operating under positive pressure.
- Horizontal runs shall be sloping upwards not less than 1/4 inch per foot (21 mm/m) from the boiler to the vent termination.
- Horizontal portions of the venting system shall be supported to prevent dips or sags where condensate could collect.
- Rigidly support vent pipe every 5 feet and at the elbows. Plumber straps may be used.
- ALL vent pipe and fittings must be installed with appropriate air space clearances to combustibles. These air space clearances apply to indoor or outdoor vents, whether they are open, enclosed, horizontal or vertical or pass through floors, walls, roofs, or framed spaces. The appropriate air space clearances should be observed between joists, studs, sub floors, plywood, drywall, or plaster enclosures, insulated sheathing, rafters, roofing, and any other combustible material. The minimum air space clearance also applies to electrical wires and any kind of building insulation. For horizontal runs, keep 4 inch and 6 inch vent piping from any contact with any combustible material, electric wires, and building materials.

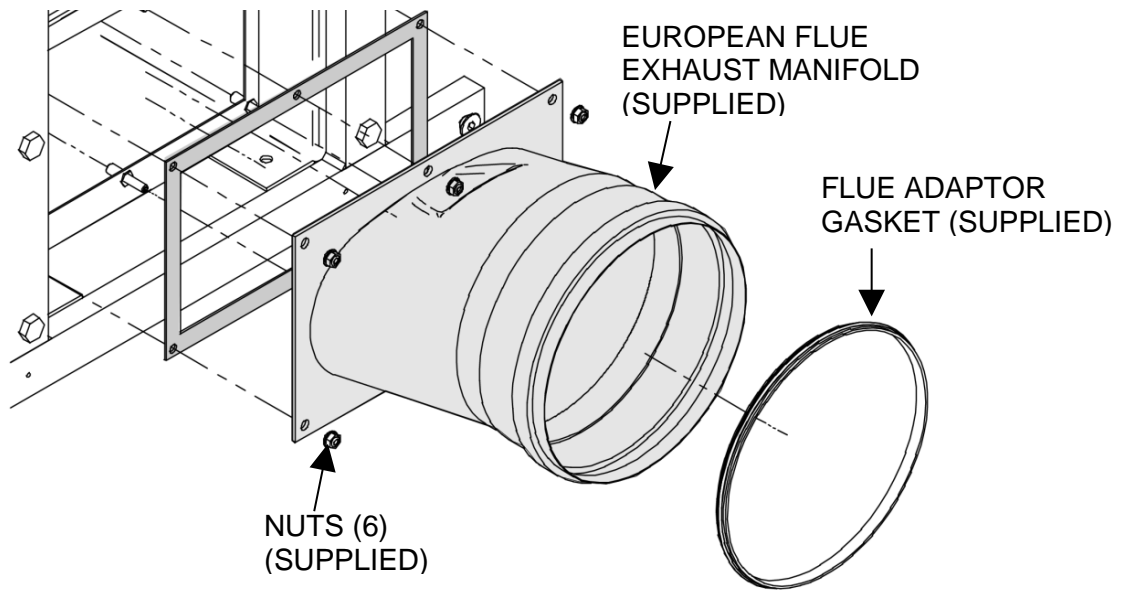

Figure 11: Connection of Exhaust Manifold to Flue Exhaust Outlet (EXT 321 – 1123)

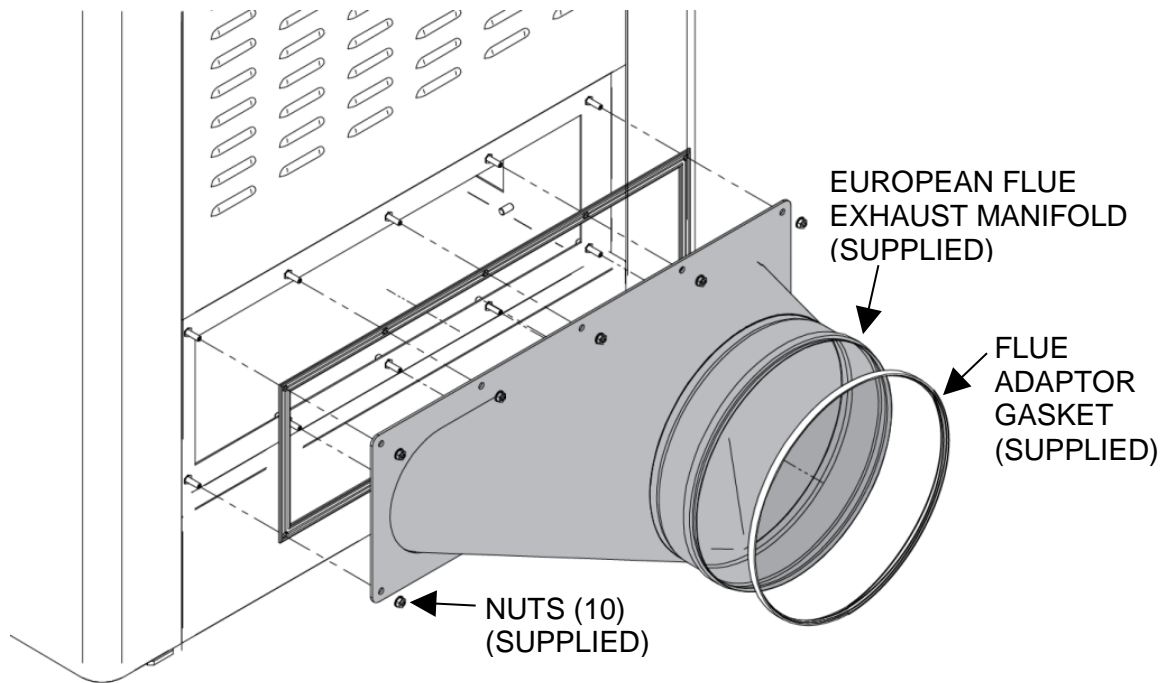

Figure 12: Connection of Exhaust Manifold to Flue Exhaust Outlet (EXT 1500 – 3060)

NOTE:
The gasket may seem large. It is intentionally designed to produce a tight fit.

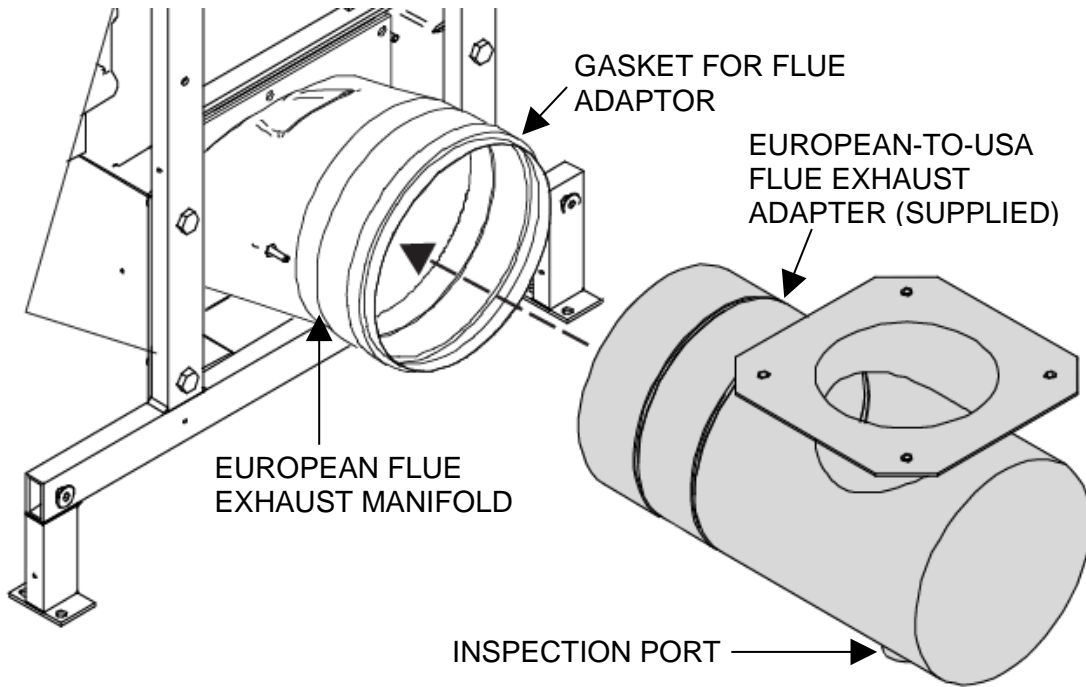

Figure 13: Assembly of USA Adaptor to European Flue Manifold (EXT 321 – 1123)

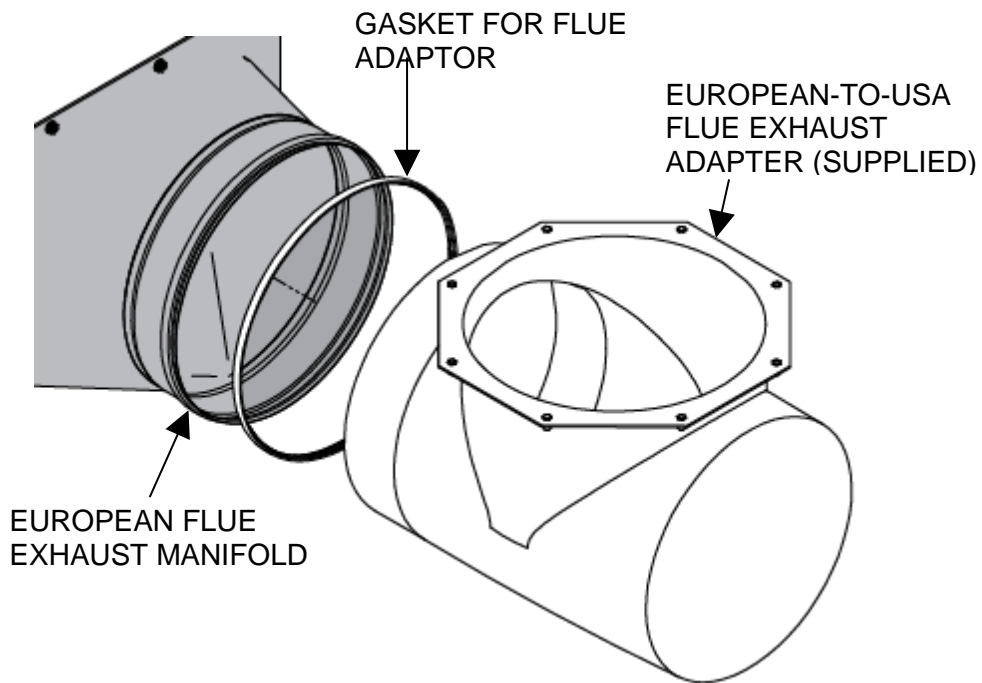

Figure 14: Assembly of USA Adaptor to European Flue Manifold (EXT 1500 – 3060)

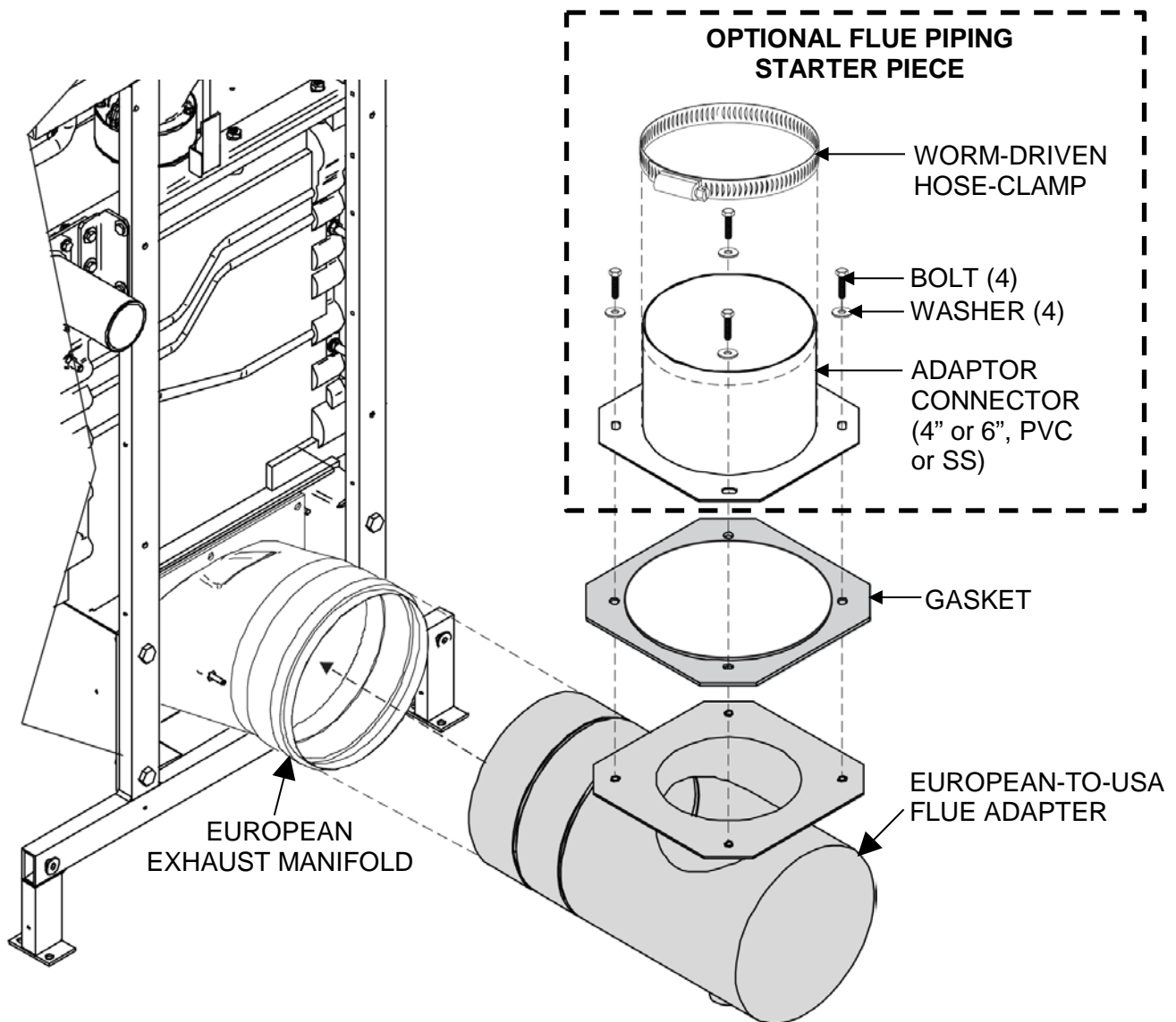

Figure 15: Flue Piping Starter Piece Assembly (EXT 321 – 1123)

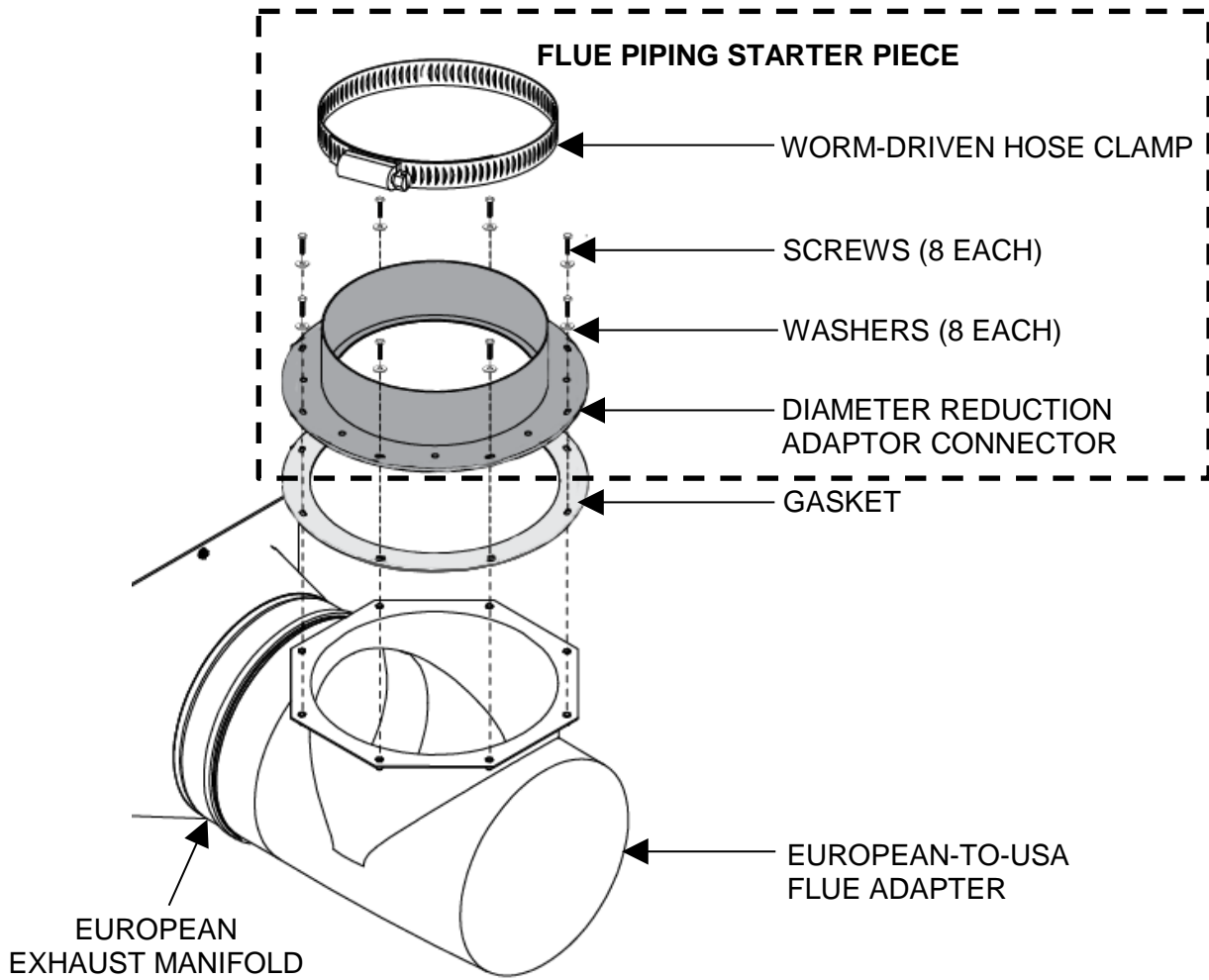

Figure 16: Flue Piping Starter Piece Assembly (EXT 1500 –3060)

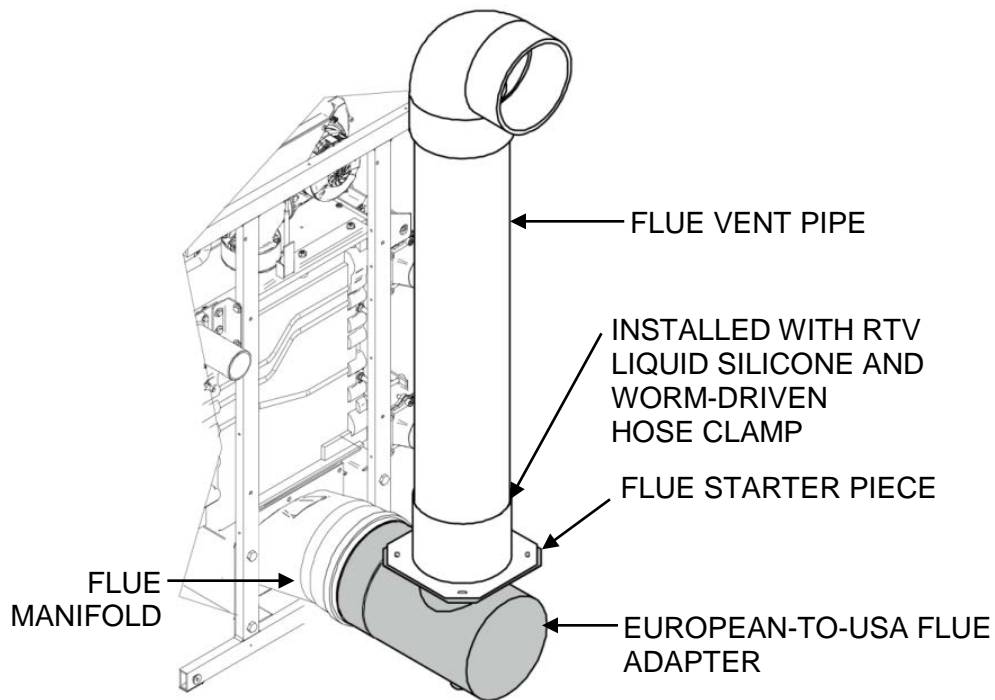

Figure 17: Installed Flue Piping Starter Piece (EXT 321 – 1123)

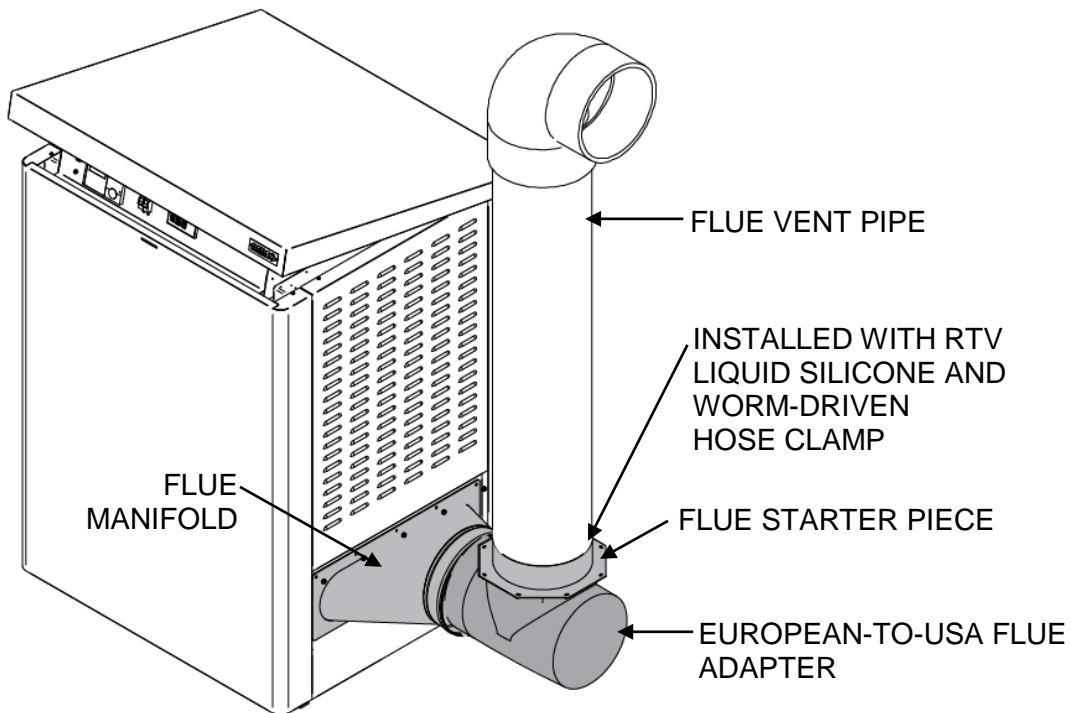

Figure 18: Installed Flue Piping Starter Piece (EXT 1500 –3060)

WARNING!
Do not insulate or otherwise wrap vent pipe or Fittings.

NOTE:

Specific installation regulations for side-wall and vertical terminations, respectively, are described in the following two sections (Sections 3.2 and 3.3).

3.2. INSTALLATION PROCEDURE FOR VENTING SYSTEM THROUGH WALLS

The minimum distances from adjacent public walkways, adjacent buildings, operable windows and building openings shall not be less than those values specified in the National Fuel Gas Code, ANSI Z223.1 and/or CAN/CGA B149, Installation Codes.

Minimum clearance of 4 feet (1.22 m) horizontally from, and in no case above or below, unless a 4-foot (1.22 m) horizontal distance is maintained, from electric meters, gas meters, regulators and relief equipment.

Refer to the notes below and Figure 19, when determining the location of the vent outlet.

- a) At least 12 inches (31 cm) above finished grade, or at least 12 inches (31 cm) above the normally expected snow accumulation level in geographical areas where snow accumulates. With a vent termination clearance of at least 4 feet (122 cm) from any air openings into a building.
- b) In Massachusetts, when side-wall venting is used, the vent termination must be located a minimum of 4 feet above grade. For detailed information pertaining to side-wall venting within the Commonwealth of Massachusetts, refer to pages 8 and 9 in the MLX EXT manual, GF-136.
- c) At least 3 feet (92 cm) above any forced air inlet located within 10 feet (305 cm).
- d) At least 4 feet (122 cm) horizontally from electric meters, gas meters, regulators and relief equipment.
- e) For horizontal runs, keep vent pipes away from any combustible material, electric wires, and building insulation.
- f) Do not terminate vent over public walkways or over an area where condensate or vapor could create a nuisance or hazard or could be detrimental to the operation of regulators, relief valves, or other equipment.
- g) Do not locate the vent termination too close to shrubbery as flue products may stunt growth or kill them.
- h) Some building materials may be affected by flue products expelled near unprotected surfaces. Sealing or shielding of exposed surfaces with a corrosion resistant material (such as aluminum sheet) may be required to prevent staining or deterioration.

See the National or Canadian Codes listed at the beginning of these instructions for additional information on termination location.

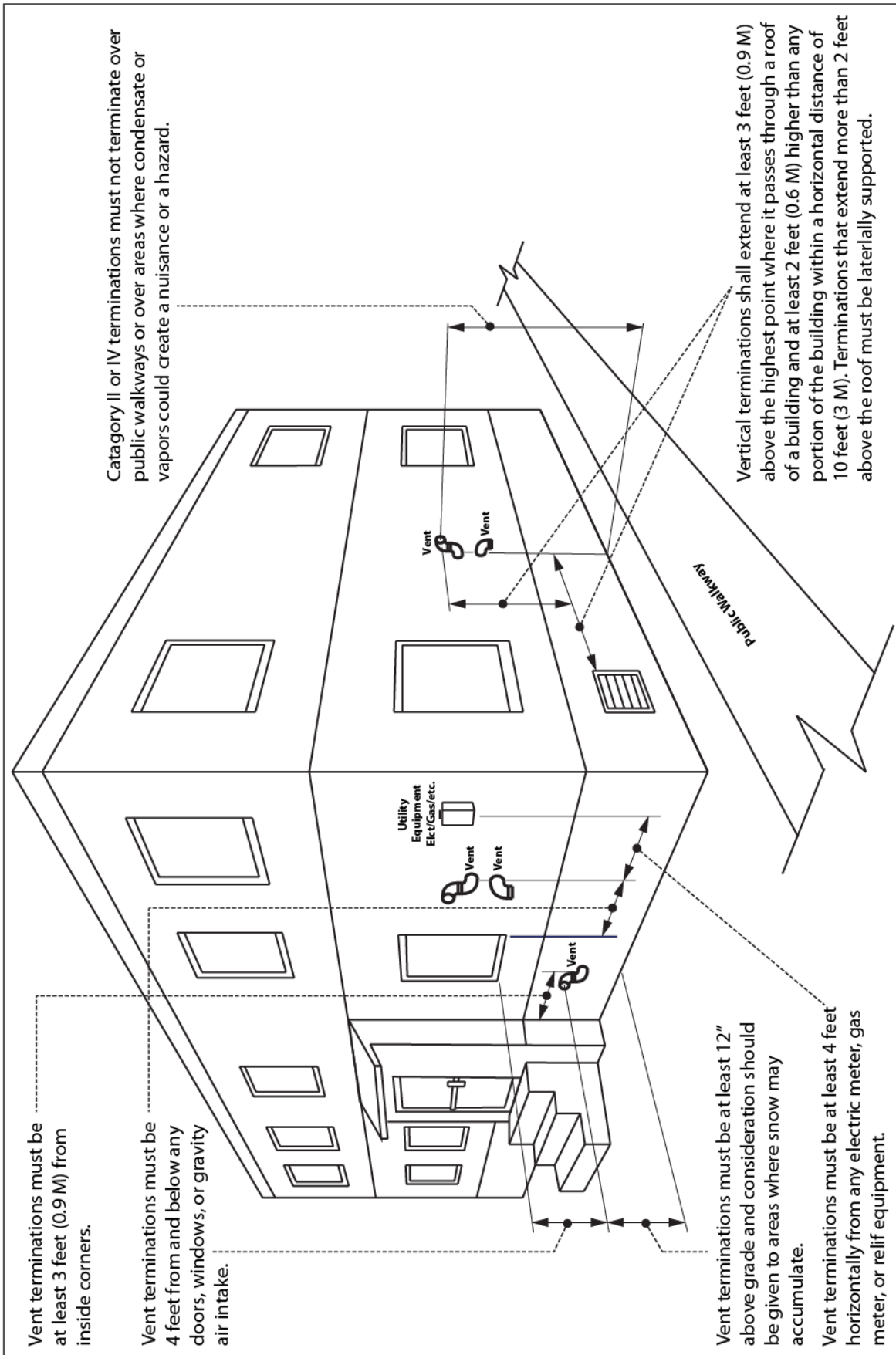

Figure 19: Determining Location of Vent Outlet

3.3. INSTALLATION PROCEDURE FOR VERTICAL VENTING

WARNING!
Do not insulate or otherwise wrap vent pipe or fittings. Follow the vent pipe manufacturer's installation instructions for vertical venting.

WARNING!
Non-motorized louvers and grilles must be fixed in an open position.
Minimum screens mesh size shall not be smaller than ¼ inch mesh.

The Vent Termination Must Be Located As Follows:

- a. Unit is certified for zero clearance to combustible materials.
- b. Combustion air inlet must be 3 ft. below any vent outlet, within 10 ft. See Figure 20.
- c. Vertical terminations shall extend at least 3 ft. (0.9 m) above the highest point where it passes through a roof of a building and at least 2 ft. (0.6 m) higher than any portion of the building within a horizontal distance of 10 ft. (3 m). Terminations that extend more than 2 ft above the roof must be laterally supported.
- d. Combustion air inlet must also face away from the vent outlet. See Figure 20.
- e. Use vent pipe manufacturers vent or rain cap, fire stop, support collar, roof flushing, and storm collar.

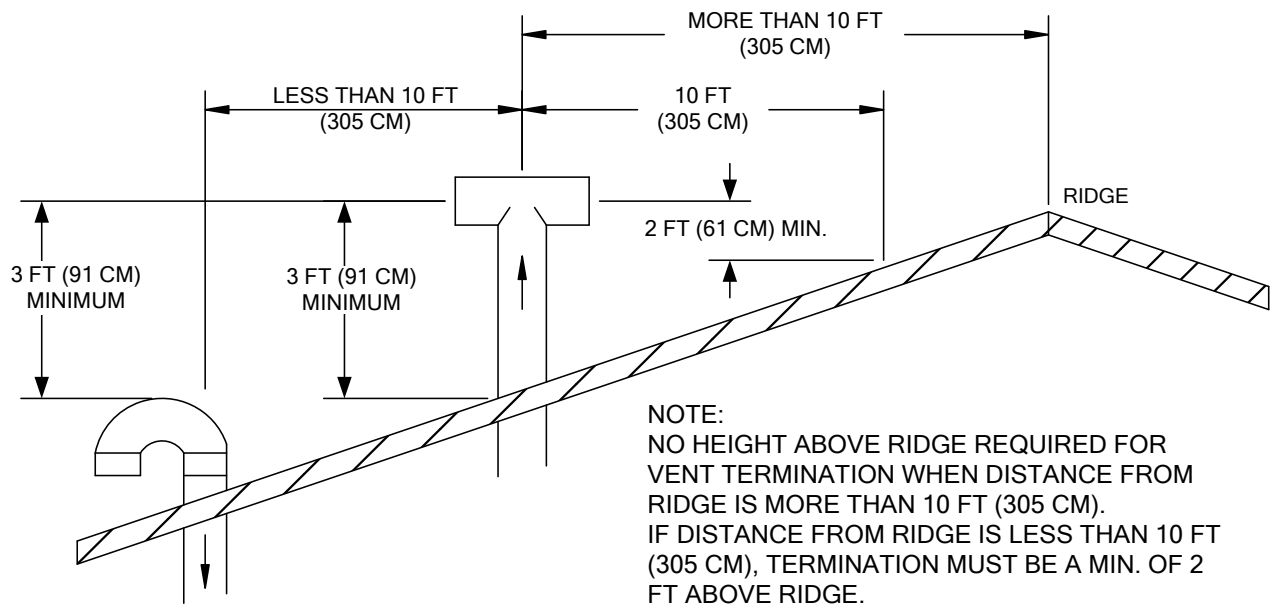

Figure 20: Vent Termination Locations

3.4. VENT PIPING SIZE

The maximum length is the combined length of straight horizontal and vertical runs, and the equivalent straight length of fittings. The required lengths for each boiler are as shown on Table 5 and 11.

TABLE 5: Venting Pipe Run Lengths						
MODEL NO.	VENT PIPE DIAMETER	EQUIVALENT VENT LENGTH EXAMPLES				MAXIMUM LENGTH EQUIV. FT (M)
		Sharp 90° Elbow Equiv. Ft. (m)	Sweep 90° Elbow Equiv. Ft. (m)	45° Elbow Equiv. Ft. (m)	Termination Tee; Equiv. Ft. (m)	
EXT 321 EXT 481/450	4" (102 mm)	10 ft. (3.05 m)	5 ft. (1.5 m)	5 ft. (1.5 m)	5 ft. (1.5 m)	100 ft. (30.5 m)
EXT 641/600 EXT 802/800 EXT 962 EXT 1123/1100	6" (152 mm)	10 ft. (3.05 m)	N/A	5 ft. (1.5 m)	5 ft. (1.5 m)	100 ft. (30.5 m)
EXT 1530/1500 EXT 1912	10" (254 mm)	10 ft. (3.05 m)	N/A	5 ft. (1.5 m)	TBD	100 ft. (30.5 m)
EXT 2295/2300 EXT 2677/2600 EXT 3060/3000	12" (305 mm)	10 ft. (3.05 m)	N/A	5 ft. (1.5 m)	TBD	100 ft. (30.5 m)

The maximum pressure drop of the combustion air piping is also 100 equivalent feet (30.5 m). See Section 2.2. Note that this does NOT mean the allowed combined pressure drop between the vent and combustion air is 200 equivalent feet (61 m). That is, the vent cannot go above 100 equivalent feet (30.5 m), even if the combustion air is less than 100 equivalent feet, and vice versa.

EXAMPLES:

1. A 40 foot (12.2 m) length of vent pipe and 1 sharp 90° elbow plus a termination vent cap (rain cap) add up to 40 ft. + 10 ft. + 10 ft. = 60 equivalent ft. (18.3 m).
2. A 30 foot (10.4 m) length of vent pipe and 2 sharp 90° elbows plus a termination rain add up to 30 ft. + (2 x 10 ft.) + 10 ft. = 50 equivalent ft. (18.3 m).

3.5. COMMON VENT PIPING SIZE

Refer to Figures 6, 7 and 8 in Section 2 for typical common vent installations. The maximum length is the sum of the equivalent straight length of horizontal runs, vertical runs, and fittings of the individual vent connector and the common vent pipe. The maximum length is the combined length of straight horizontal and vertical runs, and the equivalent straight length of fittings. The required diameters for a given Modulex total BTU/hr. Input are shown in Table 6, below.

TABLE 6: Common Venting Pipe Run Lengths						
TOTAL BTU/HR INPUT (UP TO AND INCLUDING)	Common Vent Diameter	EQUIVALENT COMMON VENT LENGTHS EXAMPLES				MAX. LENGTH → INDIVIDUAL CONNECTOR PLUS COMMON VENT EQUIVALENT FT (M)
		Sharp 90° Elbow Equiv. Ft (m)	Sweep 90° Elbow Equiv. Ft (m)	45° Elbow Equiv. Ft (m)	WYE or Termination Tee or Vent Cap Equiv. Ft (m)	
606,000	4" (102 mm)	10 ft. (3.05 m)	5 ft. (1.5 m)	5 ft. (1.5 m)	5 ft. (1.5 m)	100 ft. (30.5 m)
1,284,000	6" (152 mm)	10 ft. (3.05 m)	N/A	5 ft. (1.5 m)	5 ft. (1.5 m)	100 ft. (30.5 m)
2,407,500	8" (203 mm)	10 ft. (3.05 m)	N/A	5 ft. (1.5 m)	5 ft. (1.5 m)	100 ft. (30.5 m)
3,825,000	10" (254 mm)	10 ft. (3.05 m)	N/A	5 ft. (1.5 m)	5 ft. (1.5 m)	100 ft. (30.5 m)
5,355,000	12" (305 mm)	10 ft. (3.05 m)	N/A	5 ft. (1.5 m)	5 ft. (1.5 m)	100 ft. (30.5 m)
6,885,000	14" (358 mm)	10 ft. (3.05 m)	N/A	5 ft. (1.5 m)	5 ft. (1.5 m)	100 ft. (30.5 m)
9,180,000	16" (407 mm)	10 ft. (3.05 m)	N/A	5 ft. (1.5 m)	5 ft. (1.5 m)	100 ft. (30.5 m)

- NOTES:
- The chart above shows equivalent pipe lengths of the fittings for the common vent pipe. See section 3.4 for equivalent lengths for fittings for the individual boiler connector.
 - The maximum equivalent length shown is the sum of the equivalent length of the longest individual connector plus the equivalent length of the common vent pipe. **If the maximum equivalent length exceeds 100 equivalent ft., contact your AERCO sales representative or AERCO International for design assistance and approval.**
 - It is important to use a WYE as a means to connect the individual vent into the common vent pipe. This will ensure the least amount of pressure drop. Do NOT use a TEE, 90°, or 45° elbow.

The maximum pressure drop of the combustion air piping is also 100 equivalent feet (30.5 m). See Section 2.3. Note that this does **NOT** mean that the allowed combined pressure drop between the vent and combustion air is 200 equivalent feet (61 m). That is, the vent cannot go above 100 equivalent feet (30.5 m), even if the combustion air is less than 100 equivalent feet, and vice versa.

Example:

The vent system of two MLX-802/800 (2 x 802,000 BTU/hr. = 1,604,000 BTU/hr.) consists of 30 foot length of vent pipe and 2 sharp 90° elbows. A termination vent or rain cap is also installed. Each individual vent connector consists of 5 ft. straight run and one WYE.

- Common Vent pipe: 30 ft. + (2 x 10ft) + 5 ft. = 55 equivalent ft. (16.7 m)
- Individual vent connector: 5 ft. + 5 ft. = 10 equivalent ft. (3.0 m)
- Total Vent equivalent length: 55 ft. + 10 ft. = 65 (19.7 m)

60 equivalent ft. is LESS than 100 equivalent feet: OK to use 8" Common vent piping and 6" individual connectors.

Change Log:

DATE	DESCRIPTION	CHANGED BY
02/22/2017	Rev E: DIR 17-008: Added new model numbers for units with aluminum water connections. Reformatted per new design standard.	Curtis Harvey
09/25/2017	Rev F: DIR 17-066: Modify Table 1, Specify P/N for PolyPro vents (section 1.4.3)	Chris Blair



© AERCO International, Inc., 2017