



OMM-0057_0A

INSTRUCTION
No. **HE-104**

**INSTALLATION, OPERATION,
and MAINTENANCE INSTRUCTIONS**

**HELITHERM
HEAT
EXCHANGERS**

**PACKAGED
WATER HEATERS**

MODEL SW1B-PLUS

TABLE OF CONTENTS

| <u>Section</u> | <u>Page</u> |
|--------------------------------------|-------------|
| SAFETY PRECAUTIONS | HE-104-2 |
| GENERAL INFORMATION. | HE-104-3 |
| INSTALLATION | HE-104-5 |
| PRINCIPLE OF OPERATION | HE-104-9 |
| OPERATING PROCEDURES | HE-104-10 |
| ROUTINE MAINTENANCE. | HE-104-12 |
| TROUBLESHOOTING. | HE-104-12 |
| CORRECTIVE MAINTENANCE | HE-104-13 |
| DESCALING BY THERMAL SHOCK | HE-104-14 |
| DISASSEMBLY. | HE-104-14 |
| REASSEMBLY | HE-104-16 |
| RECOMMENDED SPARE PARTS. | HE-104-18 |

SAFETY PRECAUTIONS

Installing or operating personnel must, at all times, observe all safety regulations. The following warnings are general and must be given the same attention as specific precautions included in the instructions.

WARNING!

FLUIDS UNDER PRESSURE MAY CAUSE INJURY TO PERSONNEL OR DAMAGE TO EQUIPMENT WHEN RELEASED.

SHUT OFF ALL INCOMING AND OUTGOING STEAM AND WATER STOP VALVES AND CAREFULLY DECREASE ALL TRAPPED PRESSURES TO ZERO (see SHUTDOWN in OPERATING PROCEDURES) BEFORE PERFORMING ANY MAINTENANCE.

WARNING!

LIVE STEAM CAN CAUSE SEVERE BURNS.

NEVER SEARCH FOR LEAKAGE IN A LIVE STEAM LINE BY SIGHT ALONE OR BY "FEEL". USE A MIRROR OR OTHER SUITABLE POLISHED OBJECT. ALSO, ALWAYS WEAR GLOVES AND LONG SLEEVES.

GENERAL INFORMATION

This instruction covers AERCO Helitherm Series B-PLUS Steam to Water Heat Exchangers. Steam is the primary or tube side fluid. The water being heated (service or domestic water or other fluid) is the secondary or shell side fluid.

The number of coils in a particular Heat Exchanger is denoted by the two digits following the "+" and preceding the first "/" in the Heat Exchanger Model Number. That is, 03 = 3 coils, 07 = 7 coils, 11 = 11 coils, 15 = 15 coils, etc.

The "Style" designation for a Heat Exchanger denotes materials of construction for the various components of the assembly. If this information is required for a specific Heat Exchanger, contact the nearest AERCO Sales Representative.

ACCESSORIES

Accessories included in the AERCO B-Plus Heat Exchanger Package Assembly are (see Figures HE-104-1, HE-104-9, HE-104-15, HE-104-17, and HE-104-18):

Steam Flow Control Valve -- either Air Operated or Self Contained as ordered, sized as required for the service

Temperature Controller -- installed in the Control Box when an Air Operated Control Valve is furnished

Over-Temperature Limit System, including the following:

Temperature Switch -- installed in the Control Box

Solenoid Valves --

Water -- installed in Heater Top Head

Air -- installed in Control Box when Air Operated Control Valve is furnished

Steam -- installed on Self Contained Control Valve when furnished

Indicator Lights -- "Power On" and "Tripped" -- installed in Control Box

Steam Pressure Gage -- mounted below Control Box

Shell Hot Water Outlet Temperature Gage -- mounted below Control Box

Pressure & Temperature Relief Valve(s) -- size and number furnished as required in accordance with the design Btu output of the Heater -- first two located in the Heater Top Head as shown in Figure HE-104-1; third, if furnished, to be installed in the hot water outlet piping by the user as shown in Figure HE-104-6

Union Orifice -- located in Condensate Outlet (see Figure HE-104-1) -- required in place of a steam trap to insure complete condensation of steam within the Heater

Check Valve -- located in Condensate Outlet

All other items -- stop valves, check valves, strainers, unions or flanges, and other piping and fittings as shown in Figures HE-104-2 through HE-104-5 -- are to be furnished by others.

NOTE

The AERCO Helitherm Heat Exchanger carries the standard AERCO warranty against defective material and workmanship. HOWEVER, AERCO cannot honor its warranty if the installer or user deviates in any way from the instructions and precautions included herein or makes any alteration of the equipment from that as originally furnished without the written approval of AERCO.

NOTE

THIS INSTRUCTION COVERS ONLY THE HEAT EXCHANGER PORTION OF THE MODEL B-PLUS PACKAGED HEATER ASSEMBLY. SEPARATE INSTRUCTIONS ARE INCLUDED IN THIS PACKAGE COVERING THE STEAM CONTROL VALVE, THE OVER-TEMPERATURE LIMIT SYSTEM AND ITS COMPONENTS, AND OTHER ACCESSORIES INCLUDED IN THE HEATER PACKAGE.

| HEAT EXCHANGER DESIGN STANDARDS | | | |
|----------------------------------|-----------------------|--------------------------|-------------------------|
| MAX. WORKING PRESSURE PSIG (MPa) | MAX. TEMP. OF °F (°C) | TEST PRESSURE PSIG (MPa) | TEST PRESSURE MPa (PSI) |
| | | | |
| TUBE SIDE | 250 (672) | 375 (25.84) | 375 (25.84) |

| MATERIALS OF CONSTRUCTION | |
|---------------------------|--|
| PRESSURE VESSEL | 3/16" (0.48) CARBON STEEL SHELL, SA 286 COPPER LINER, ASTM B-152 BRONZE HEADS, SB-62 |
| TUBE BUNDLE | COPPER COILS, 0.049" (0.13) WALL, SB-III RED BRASS RISER, SB-43 |

| HEATER MODEL | NO. OF COILS | HEATING SURFACE SQ. FT. (SQ. M.) | DIMENSIONS (INCHES) | | APPROX. WT. LBS. (KG) |
|--------------|--------------|----------------------------------|---------------------|-----------------|-----------------------|
| | | | A | B | |
| SWIB+03 | 3 | 15 (1.39) | 40.75 (103.51) | 55.00 (125.70) | 460 (209) |
| SWIB+05 | 5 | 25 (2.32) | 49.75 (126.37) | 64.00 (162.56) | 590 (268) |
| SWIB+07 | 7 | 35 (3.25) | 58.75 (148.23) | 73.00 (186.42) | 610 (277) |
| SWIB+09 | 9 | 45 (4.18) | 67.75 (172.09) | 82.00 (208.28) | 680 (308) |
| SWIB+11 | 11 | 55 (5.11) | 76.75 (194.95) | 91.00 (231.14) | 740 (336) |
| SWIB+13 | 13 | 65 (6.04) | 85.75 (217.81) | 100.00 (254.00) | 810 (368) |
| SWIB+15 | 15 | 75 (6.97) | 94.75 (240.67) | 109.00 (276.86) | 870 (395) |

DIMENSIONS SHOWN ARE IN INCHES
DIMENSIONS IN () ARE IN CENTIMETERS

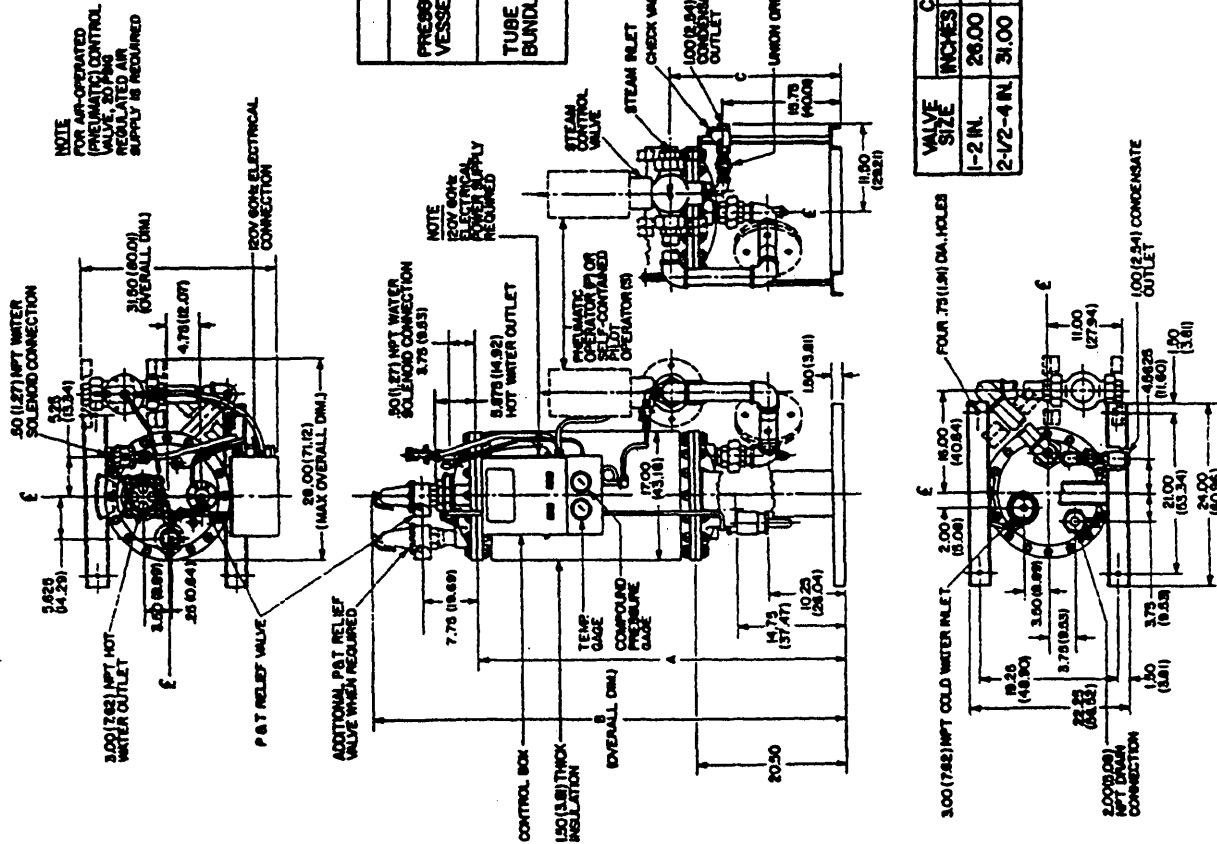

Figure HE-104-1 -- Dimensions for AERCO Helitherm Heat Exchanger (Packaged Water Heater), Model SWIB-PLUS

INSTALLATION

1. Dimensions for an AERCO Heat Exchanger (Heater) Model SW1B-Plus are shown in Figure HE-104-1.
2. Uncrate the Heater carefully. Set the Heater upright by using a block and tackle or hoist attached to the lifting lugs on the top head of the Heater (the eye-bolts shown in Figure HE-104-16). Always use the lifting lugs to lift and/or move the Heater.
3. If possible, for easy in-place maintenance, locate the Heater where there is at least 2 feet clearance all around the Heater and where the head room clearance from the top of dimension B in Figure HE-104-1 is at least equal to dimension A for the Heater Model less 24 inches.
4. It is suggested that the Heater stand assembly be secured to the floor. However, any other means for securing the Heater may be used. If piping is used to secure the Heater, the piping must include ample provision for expansion.
5. Make all piping connections as instructed in Step 6 below and in accordance with the appropriate Figure showing:
 - Single Heater -- Figure HE-104-2
 - Parallel Heaters -- Figure HE-104-3
 - Single Heater used with an Accumulator -- Figure HE-104-4
 - Single Heater used with a Stratified Storage Tank -- Figure HE-104-5or with any specific piping diagram which may have been furnished by AERCO for this installation.
6. For best Heater performance, observe the following very carefully in making the piping installation:
 - a. Do not use cement or red lead in making up pipe joints.
 - b. For Heater connection types, sizes, and exact locations, see Figure HE-104-1.
 - c. All piping to the Heater top head should be provided with unions or flanges which are located beyond the outside diameter of the Heater head to permit removal of the head and shell for in-place maintenance.
 - d. Include all of the stop valves, check valves, steam traps, and other elements in the piping as shown in Figure HE-104-2, HE-104-3, HE-104-4, or HE-104-5, or as separately specified by AERCO. Note that the check valve shown at the Heater in the Condensate return line is furnished in the piping package assembly by AERCO.
 - e. The Condensate return piping should be arranged to permit Condensate to drain freely by gravity from the Heater bottom head. Failure to do so may result in Heater improper operation and/or in damage to the Heater Steam/Condensate system.
 - f. All drain discharges -- relief valve(s) in the top head of the Heater, outlet of the water solenoid valve in the top head of the Heater, and drain valve in the bottom head of the Heater -- should be piped directly to a convenient floor drain.
7. When a third P&T Relief Valve is furnished with the Heater (the first two furnished have been assembled in the top head of the Heater by AERCO), the third Valve is to be installed in the Heater hot water outlet piping, by the user, as illustrated in Figure HE-104-6.
8. Before making final piping connections to and from the Heater and Control Valve, blow out all piping thoroughly.
9. If an air-operated Control Valve is furnished in the Heater package, make the necessary supply air connection to the connector through the side of the Control Box (see Figure HE-104-9). The supply air pressure must be maintained at 20 psig.
10. Connect 110 v 60 Hz power supply wiring through the side of the Control Box to the electrical junction box (see Figure HE-104-9).

LEGEND

| | | | |
|--|-------------------------|--|----------------|
| | STOP VALVE | | STRAINER |
| | CHECK VALVE | | RELIEF VALVE |
| | CONTROL VALVE | | THERMOMETER |
| | ORIFICE UNION | | STEAM TRAP |
| | CONTROL THERMAL ELEMENT | | CIRCULATOR |
| | PRESSURE GAGE | | BALANCING COCK |
| | PIPE UNION OR FLANGES | | PETCOCK |
| | COMPOUND PRESS. GAGE | | FLOW INDICATOR |

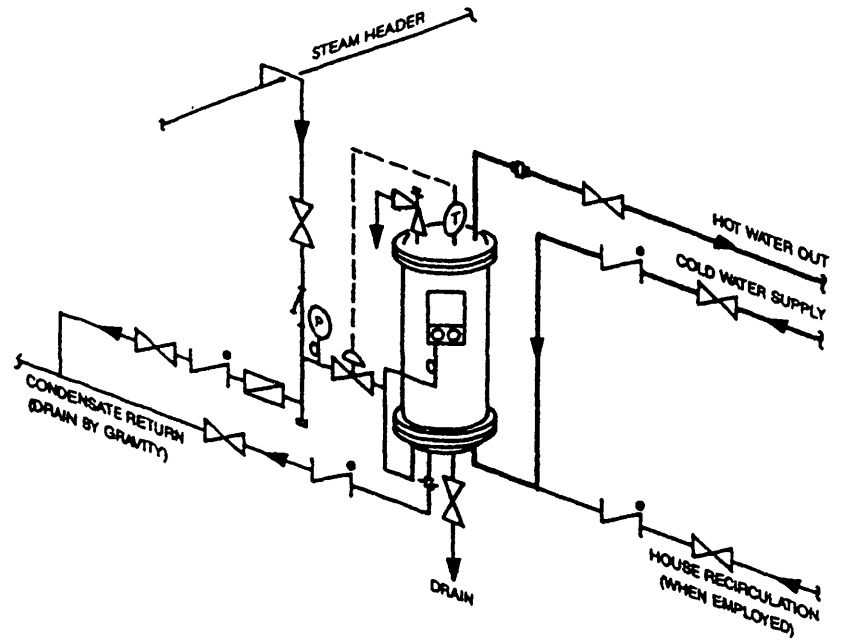

Figure HE-104-2 -- Piping Connections for a Single Heater

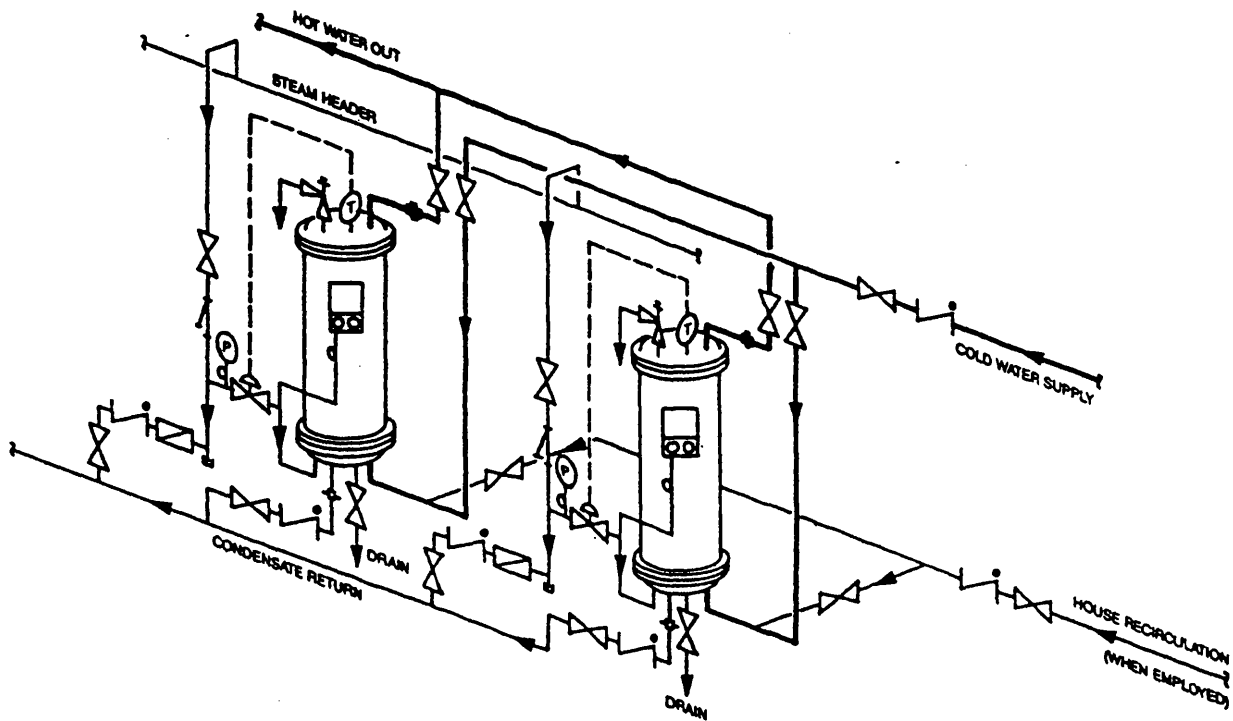

Figure HE-104-3 -- Piping Connections for Parallel Heaters

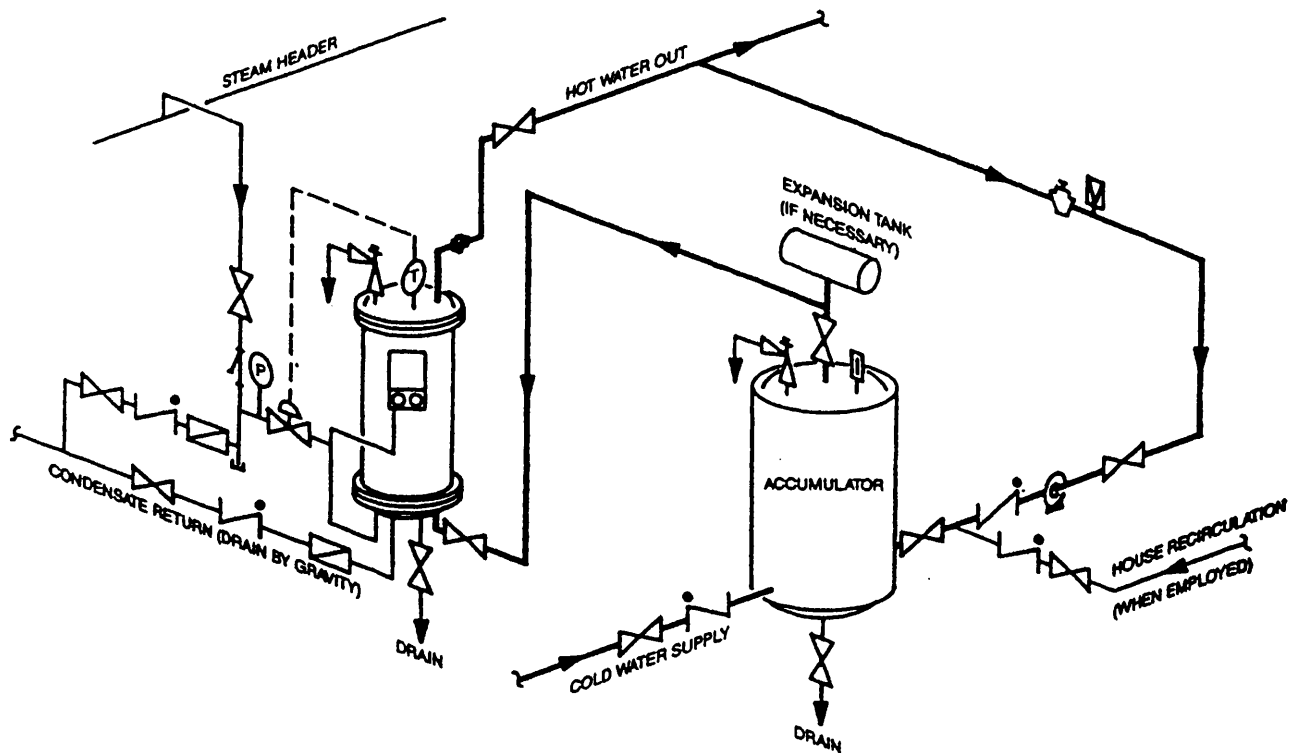

Figure HE-104-4 -- Piping Connections for a Single Heater used with an Accumulator

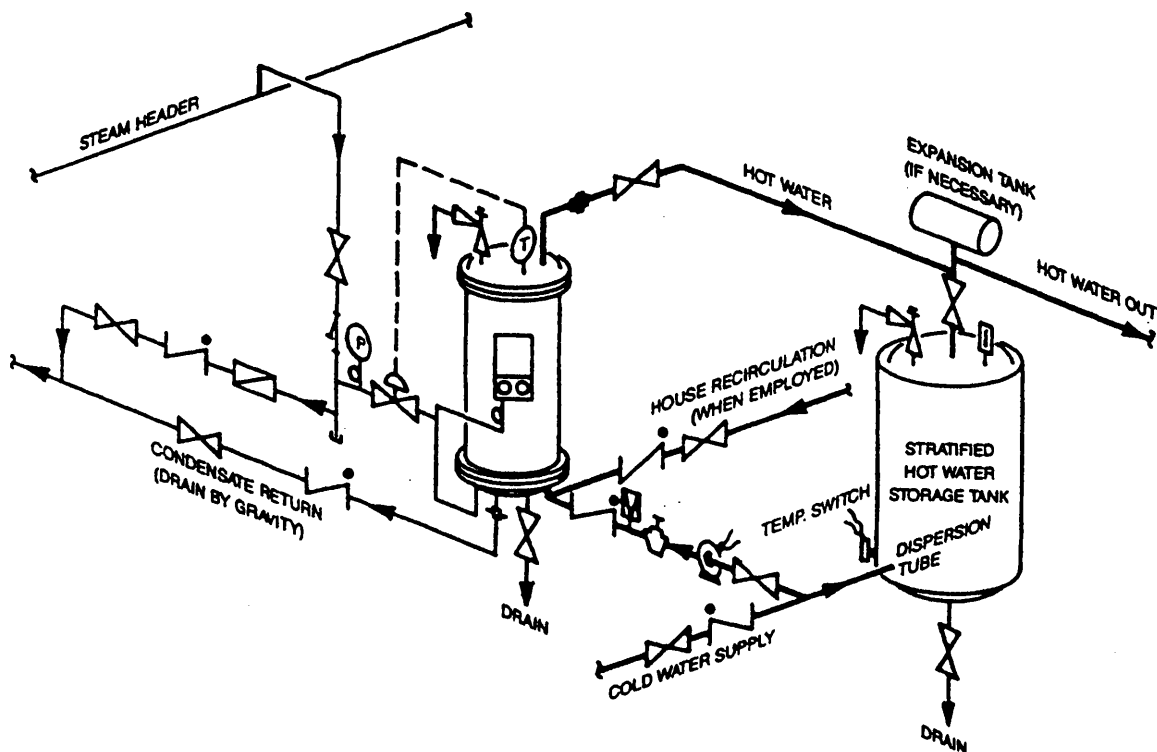
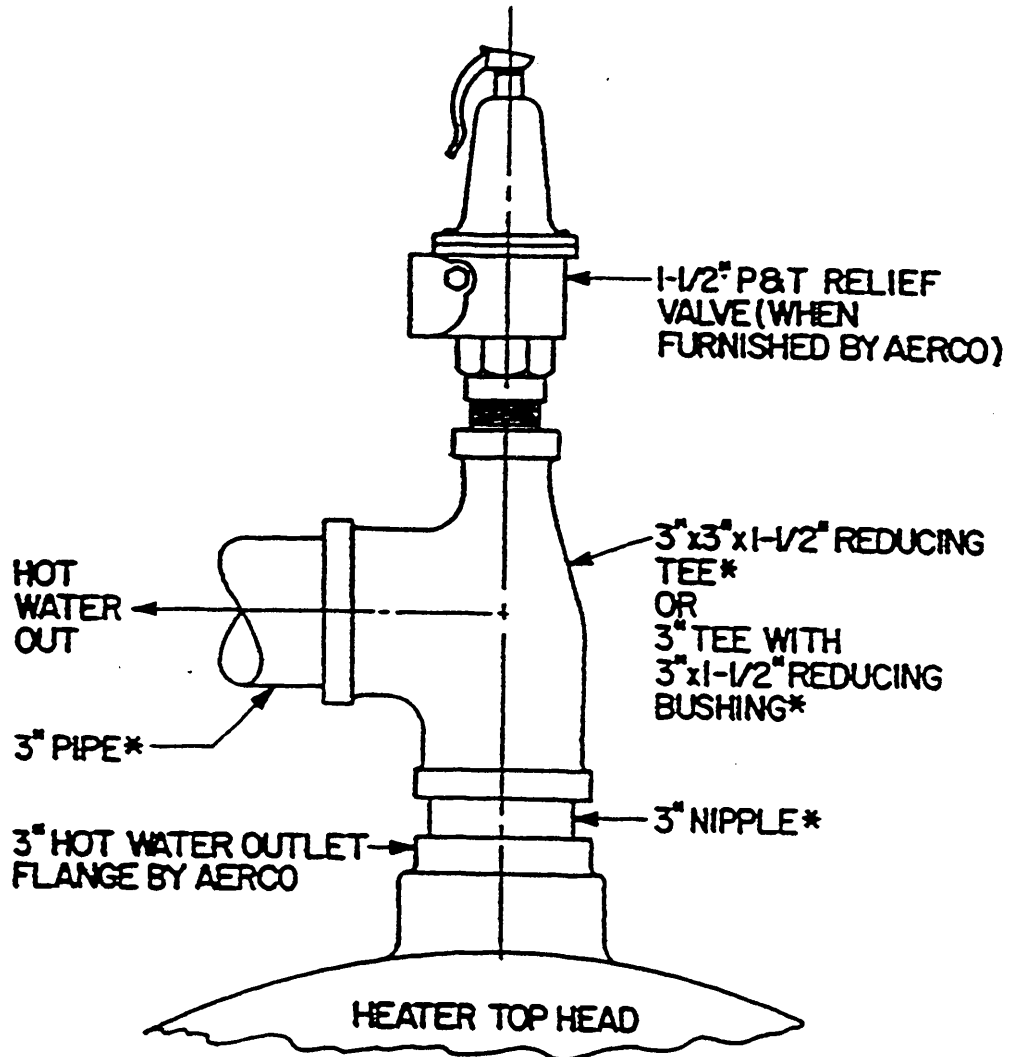

Figure HE-104-5 -- Piping Connections for a Single Heater used with a Stratified Storage Tank



*PIPING AND FITTINGS BY USER

Figure HE-104-6 -- P&T Relief Valve Located in the Heater Hot Water Outlet Piping

PRINCIPLE OF OPERATION

The AERCO Helitherm Heat Exchanger (Heater) consists of three principal parts (see Figures HE-104-7 and HE-104-8);

- 1 -- Shell with Top and Bottom Heads
- 2 -- Coils assembled to Steam Riser and Condensate Return
- 3 -- Integral Demand Anticipator Temperature Control Unit

Cold Water (or other liquid) enters the Heater through the inlet connection and orifice in the bottom head and strikes the deflector. The orifice serves to divert some Cold Water into the shunt tube, whereas the deflector disperses the incoming Cold Water evenly into the bottom of the shell. The Cold Water in the shell, then, flows upward among the coils (heating surfaces) and, heated, is discharged through the check valve and Hot Water outlet connection in the top head.

Steam enters through the control valve and its inlet connection in the bottom head and is fed through the Steam riser to the inlet of each coil unit. The Steam then flows through each coil unit simultaneously in parallel, leaves through each coil outlet as Condensate, enters the condensate return, and leaves the Heater through the condensate outlet connection in the bottom head of the Heater.

As noted above, the Cold Water being heated flows through the Heater from bottom to top. In addition, Heated Water, being of less density than Cold Water, migrates to the top of the shell by convection. These actions result in the hottest Water always being at the top of the Heater -- at the Heater outlet and at the Hot Water inlet to the Anticipator sensing tube (see Figure HE-104-8).

Hot Water from the top of the Heater shell enters the open end of the sensing tube and Cold Water enters the sensing tube from the shunt tube at a rate proportional to the load (call for Hot Water) on the Heater. The mixture of Hot and Cold Water in the sensing tube creates an average temperature which necessarily will be cooler than the temperature of the Hot Water in the top of the Heater shell.

The temperature sensing element "reads" the average temperature of the Water in the sensing tube at any given moment and signals the Steam control valve to modulate between full open or closed as necessary to maintain the required Heater Hot Water outlet temperature. With no demand or load on the Heater, the temperature sensing element reads only the temperature of the Water in the top of the Heater and at the Heater outlet. If the Water is at the required temperature or above, the sensing element signals the Steam control valve to close.

However, the moment that there is demand for Hot Water, Cold Water flows from the shunt tube to mix with the Hot Water in the sensing tube, cooling the sensing element so that it signals the Steam control valve to open. The need for Steam (heat) to the coils is satisfied at once, incoming Cold Water passing through the coils is heated, and the Heater Hot Water outlet temperature does not fall below that required.

The Anticipator Unit, therefore, as its name implies, is constantly alert to load conditions and changes, as well as to changes in the temperature of the incoming Cold Water, and provides FEED-FORWARD temperature control at all times.

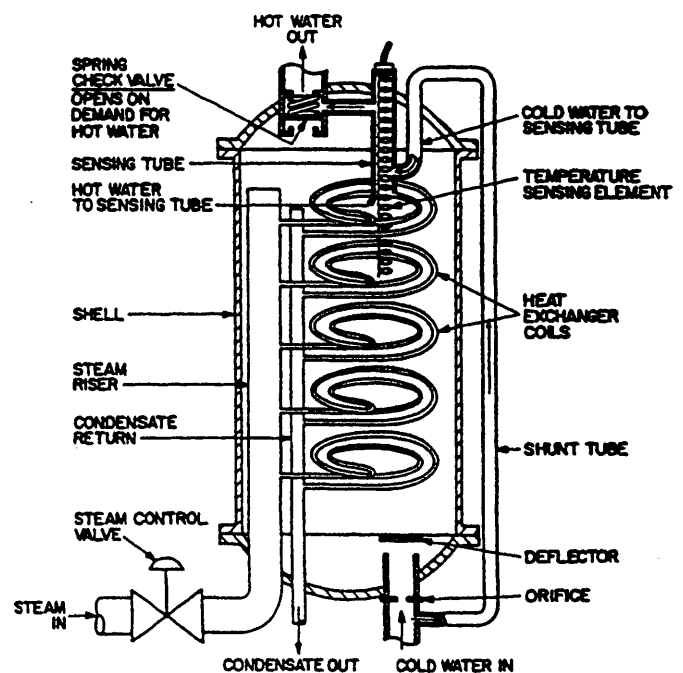

Figure HE-104-8 -- Schematic of AERCO Model 8-PLUS Water Heater showing Anticipator Temperature Control

OPERATING PROCEDURES

- OP1. With the installation entirely completed, including
-all piping connections have been made,
 -all connecting piping has been cleaned (blown) out,
 -all connections per Steps 8 and 9 under INSTALLATION have been made,
- open the stop valve in the Cold Water inlet line and hold the relief valve (or any one of the relief valves) in the Heater top head open to allow air to come out (otherwise an air pocket will be built up and the Heater will not fill). When water flows out of the relief valve, the Heater is full.
- OP2. Temporarily set the Over-Temperature Limit System Temperature Switch in the Control Box (see Figure HE-104-9) to its high temperature limit.
- OP3. If the Steam Control Valve furnished is air-operated and there is a Temperature Controller in the Control Box (see Figure HE-104-9), set the Controller at the temperature desired to be held at the Heater hot water outlet.
- OP4. Open the stop valve in the Hot Water outlet line. Open a hot water faucet or faucets in building or process to insure a flow of water through the Heater. For best results in adjusting the temperature control, a water flow of 10% to 25% of Heater rating is desirable.
- OP5. Slowly open all stop valves in the Steam inlet and Condensate outlet lines.
- OP6. Follow the instructions furnished with the air-operated Temperature Controller and Control Valve or with the self-contained Temperature Regulator Valve, and:
- a. Introduce Steam to the Heater.
 - b. Adjust the air-operated Temperature Controller or self-contained Temperature Regulator Valve until the Heater hot water outlet temperature is being held steady at the desired temperature. If the hot water outlet temperature is erratic, see Step OP7 below.
 - c. Close the hot water faucet or faucets opened in Step OP4. Open any stop valves in the building recirculation system if such is included in the Heater installation.
- OP7. If the hot water outlet temperature is erratic especially during load changes:
- a. Put a load on the Heater, by opening a hot water faucet or faucets in the building or process, as quickly as possible.
 - b. Adjust the Temperature Controller or Temperature Regulator to provide best response on load changes. See the instruction furnished with the Controller or Regulator.
- OP8. Adjust the Over-Temperature Limit System Temperature Switch in the Control Box to its proper setting in accordance with the instructions furnished which cover the Over-Temperature Limit System -- usually 15°F to 20°F higher than the desired hot water outlet temperature.
- OP9. The Heater installation is now set for operation. No further operation procedure is necessary unless or until further temperature control adjustments may be required. If so, repeat Steps OP4, OP5, OP6, and, if necessary, Step OP7.
- OP10. To SHUT DOWN the system:
- a. Close all stop valves in the Steam inlet and Condensate outlet lines.
 - b. In this order, close the stop valves in
 - (1) the hot water outlet line,
 - (2) the recirculation line, if any, and
 - (3) the cold water inlet line.
 - c. If the system includes an accumulator or stratified storage tank, do not shut off the cold water until the Heater has cooled down. If the system is allowed to cool while the cold water is shut off, the Heater liner may collapse because of formation of a vacuum.
- OP11. For DRAINING THE HEATER, see the instructions included under ROUTINE MAINTENANCE.
- OP12. To START UP again, with the shell filled per Step OP1 above, open the stop valves in the following order:
- (1) stop valve in the Cold Water inlet line,
 - (2) any stop valve in the recirculation line, if any,
 - (3) stop valve in the Hot Water outlet line, and
 - (4) stop valves in the Steam inlet and Condensate outlet lines.
- OP13. After each startup, check the temperature control. If necessary, make adjustments per Steps OP4 through OP8 above.

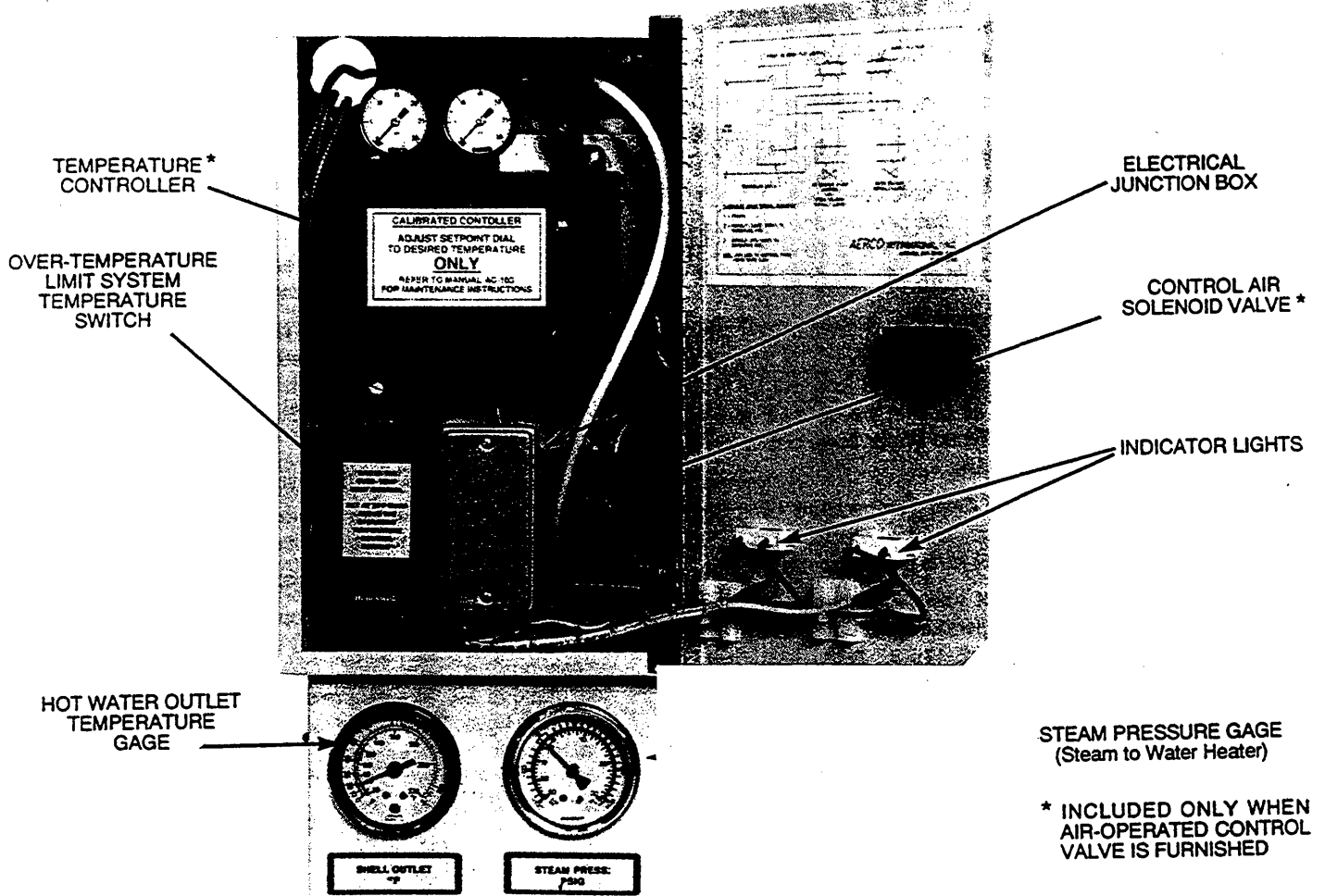

Figure HE-104-9 -- Model B-PLUS Heater Control Box

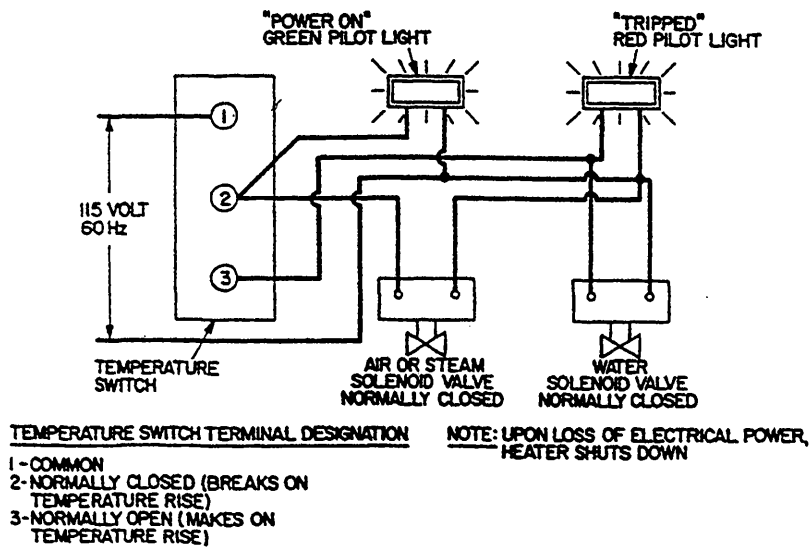

Figure HE-104-10 -- Over-Temperature Limit System Wiring Diagram

ROUTINE MAINTENANCE

The constant flexure of the Heater coils under varying load conditions automatically provides a descaling action and prevents a buildup of brittle scale. A periodic blowdown (draining) is required to remove accumulated solids.

After the first 3 months of initial operation, drain the Heater as outlined below. Examine the water being drained.

- (a) If the amount of solids appears to be heavy, set a schedule to drain the Heater every 3 months.
- (b) If the amount of solids appears to be light, set a schedule to drain the Heater every 6 months.
- (c) Even if the amount of solids appears to be very light, drain the Heater at least once each year.
- (d) Also see TROUBLESHOOTING and CORRECTIVE MAINTENANCE below. If descaling by thermal shock is required, schedule that procedure in your Routine Maintenance.

Check the temperature control at least once every 3 months. Make any necessary adjustments per Steps

OP4 through OP8 under OPERATING PROCEDURES above.

DRAIN THE HEATER as follows:

- RM1. Close all stop valves in the Steam inlet and Condensate outlet lines.
- RM2. In this order, close the stop valves in
 - (1) the hot water outlet line,
 - (2) the recirculation line, if any, and
 - (3) the cold water inlet line.
- RM3. Carefully open the relief valve (or one of the relief valves) in the Heater top head to relieve pressure in the Heater shell. If water continues to flow from the relief valve one of the water stop valves either leaks or is not shut off tight. This must be remedied until there is no more flow through the relief valve.
- RM4. With the relief valve being held open (to prevent creating a vacuum in the shell), open the drain valve and drain the Heater complete
- RM5. To refill the Heater and place it back into operation, close the drain valve and proceed through Steps OP1, OP12, and OP13 under OPERATING PROCEDURES above.

TROUBLESHOOTING

| SYMPTOM | PROBABLE CAUSE & REMEDY CORRECTIVE MAINTENANCE (CM) ITEM NO. |
|--|---|
| A. Heater does not maintain required temperature at rated capacity | CM1, CM2, CM6, CM12, CM14, CM17, CM18, CM19 |
| B. Heater overheats | CM1, CM5, CM6, CM8, CM11, CM13, CM14 |
| C. Hot Water outlet temperature fluctuates widely | CM2, CM6, CM11, CM12, CM13, CM14, CM17, CM19 |
| D. Insufficient Water through or from Heater | CM3, CM15 |
| E. Excess or insufficient Condensate being returned from Heater | CM6, CM17 |
| F. Steam being discharged into Condensate drain | CM18, CM19 |
| G. Pressure/Temperature Relief Valve pops | CM4, CM5, CM6, CM8, CM9, CM10, CM11, CM13, CM14, CM16 |
| H. Heater shuts down below, at, or too near above required hot water temperature | CM16 |
| I. Loud banging in Heater or in Steam or Condensate piping (not to be confused with a normal clicking noise) | CM6, CM7, CM9, CM10 |

CORRECTIVE MAINTENANCE

Refer to TROUBLESHOOTING.

The following are probable causes and remedies for improper action of the Heater.

- CM1. The temperature gage or steam pressure gage, or the steam supply pressure gage ahead of the Control Valve, may read wrong. Check each with a gage which is known to be correct.
- CM2. Steam pressure is too low. Check the steam supply pressure gage ahead of the Control Valve. If the reading is low, adjust the steam supply pressure to that which is required. If there is a restriction in the steam supply line, the gage reading will drop excessively when the Heater calls for full steam even though the pressure appears to be normal when the load is light. If the steam supply pressure is correct, the steam pressure gage (below the Control Box) reading should reach design pressure for steam in the coils as the Heater temperature drops. If it does not, check the operation of the Control Valve.
- CM3. Cold Water pressure is low. Check and correct, if necessary, the Water pressure to the Heater.
- CM4. Static pressure of the Cold Water is too high. Make the necessary corrections to bring the Water pressure below that for which the Relief Valve(s) is set.
- CM5. Water to be heated is preheated too hot. Reduce the preheating to a temperature at least 10°F under the desired Heater hot water outlet temperature.
- CM6. Condensate return piping has not been installed so that the Condensate drains freely by gravity and/or the Condensate check valve leaks or has failed. If necessary, rearrange the Condensate return piping per Step 6e under INSTALLATION above. Inspect the check valve and replace it if it is leaking or has failed. Also, check to make sure that there is no restriction in the Condensate drain line.
- CM7. Steam supply line is not properly trapped. Install a trap as indicated in Figure HE-104-2, HE-104-3, HE-104-4, or HE-104-5.
- CM8. Leaking stop valve in by-pass line, if any, around the Steam Control Valve. Maintain the stop valve to shut tight.
- CM9. Lack of expansion capability in the hot water system. Insert an expansion tank in the outlet hot water line close to the Heater.
- CM10. Insufficient shock absorbers. Insert shock absorbers (water hammer arresters) in both the cold and hot water systems as needed to eliminate shock waves.
- CM11. The Steam Control Valve does not close. Check the instructions covering the Valve.
- CM12. The Steam Control Valve does not open. Check the instructions covering the Valve.
- CM13. The temperature control thermal element (connected to the air-operated Temperature Controller or the self-operated Control Valve and located in the Heater top head) has failed. Refer to the instructions covering the Temperature Controller or Control Valve.
- CM14. The Anticipator Unit system is not operating properly. Check to make sure that the temperature sensing element has not failed (see CM13 above), that the shunt tube (item 87 in Figures HE-104-17 and HE-104-18) has not become clogged, and that the check valve at the hot water outlet is working properly (see CM15 below). Make any necessary corrections.
- CM15. The Anticipator Check Valve at the Heater hot water outlet is not working properly. Disassemble and inspect the Check Valve, clean the Valve, and repair or replace any parts as necessary per Steps D1 through D5 under DISASSEMBLY below.
- CM16. The Over-Temperature Limit System is out of adjustment or some component of the system has failed. Check out the system setting per Step OP8 under OPERATING PROCEDURES above. Inspect and repair or replace each component as necessary.
- CM17. There is a leak in the Heater coil(s), steam riser, or condensate return, causing water from the shell to leak into the heating coil system, or steam or condensate from the coil system into the shell. To verify such a leak, shut off the Steam supply and break a connection in the Condensate line -- CAREFULLY to avoid being burned. Condensate will drain from the coil system initially, but the flow should stop after a minute or two. If the flow continues, water is leaking from the pressurized shell side to the tube side of the Heater. Disassemble, inspect, repair (if possible), replace, and reassemble the Heater as outlined below under DISASSEMBLY and REASSEMBLY.
- CM18. The Heater coils are scaled up. Descale the Heater by thermal shock in the manner outlined below under DESCALING BY THERMAL SHOCK METHOD.
- CM19. The Heater is being utilized at a rate higher than its design capacity. Contact the nearest AERCO Representative for advice in remedying this problem.

DESCALING BY THERMAL SHOCK

Where, under certain conditions of continuous steady usage, the Cold Water is so hard or alkaline that normal flexure of the Heater coils (see ROUTINE MAINTENANCE) and routine blowdown (draining the Heater shell) will not remove scale build-up on the coils, the heating surfaces (coils) may be thermally shocked, without damage to any part of the Heater, to dislodge scale solids.

Proceed as follows:

- TS1. Drain the Heater per Steps RM1 through RM4 under ROUTINE MAINTENANCE above. However, instead of holding the relief valve open in Step RM4, remove the relief valve shown as Item 73(A) in Figure HE-104-17 or HE-104-18 from the Heater top head.
- TS2. Open the Heater drain valve. Leave the drain valve open until Step TS8 below.
- TS3. Connect a source of cold water (for example, a hose from a cold water faucet) to the open relief valve connection.
- TS4. Open all stop valves in the Steam inlet line and the Condensate outlet line to allow Steam to the Heater. After about 30 seconds, or until Steam is blowing out of the Condensate
- drain line, close the stop valve in the Condensate outlet line. Leave the Steam inlet line open for about 2 minutes longer, and then close all Steam inlet stop valves.
- TS5. Inject a flow of cold water through the relief valve connection for about 2 minutes. Then shut off the cold water flow and open the Condensate drain line stop valve to drain off all Condensate.
- TS6. Repeat Steps TS4 and TS5 several times until the water coming from the Heater drain appear to be relatively free of solids.
- TS7. Remove the cold water source from the relief valve connection, open the stop valve in the main Cold Water inlet line and allow a complete flushing of the Heater shell.
- TS8. After the Heater shell has been completely drained, close the Heater drain valve, replace the relief valve, and place the Heater back into operation per Steps OP1, OP12, and OP13 under OPERATING PROCEDURES above.
- TS9. If Cold Water conditions are so severe that thermal shocking does not remove scale deposits, consult the nearest AERCO Representative for advice.

DISASSEMBLY

Reference illustrations:

| | |
|-----------|--|
| HE-104-9 | Heater Control Box |
| HE-104-10 | Over-Temperature Limit System Wiring Diagram |
| HE-104-11 | Anticipator Check Valve Assembly |
| HE-104-15 | Heater Control Box Assembly |
| HE-104-16 | Heater Assembly |
| HE-104-17 | Heater Package Assembly with Air-Operated Control Valve |
| HE-104-18 | Heater Package Assembly with Self-Contained Control Valve |

Special Tools Required: (1) Torque wrench for 5/8" nuts. (2) A block and tackle or ratchet or winch hoist is recommended for lifting off the Heater top head and shell, or for lifting and moving the Heater.

To Remove Check Valve Assembly

See Figure HE-104-11

- D1. Shut down the Heater in accordance with Step OP10 under OPERATING PROCEDURES above. Manually (and carefully) open a relief valve to relieve any pressure in the Heater shell.

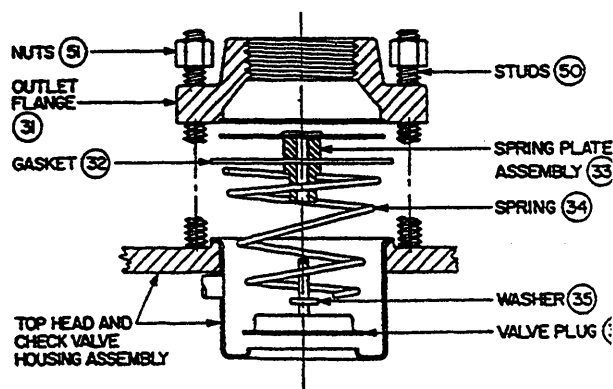

Figure HE-104-11 -- Exploded Anticipator Check Valve Assembly

- D2. Disconnect the union in the Hot Water outlet Piping (the one located beyond the outside diameter of the Heater top head). Then remove the Nuts (51) and the Outlet Flange (31) and outlet piping.
- D3. Separately, lift out the Spring Plate Assembly (33), the Gasket (32), the Spring (34), the Washer (35), and the Valve Plug (36).
- D4. Clean all parts and gasket surfaces thoroughly, and repair or replace any part necessary to make the Check Valve operate properly (open on water flow through the Heater).
- D5. See REASSEMBLY below for reassembly of the Check Valve into the Heater top head.

To Remove Heater Shell

NOTE that all part item numbers given in parentheses () in the instructions below refer to those shown in Figure HE-104-15, HE-104-16, HE-104-17, or HE-104-18.

ALSO, NOTE that it is not necessary to disassemble or remove the Check Valve Assembly (see above) in order to remove the Heater Shell.

- D6. Shut down and drain the Heater in accordance with Steps RM1 through RM4 under ROUTINE MAINTENANCE above.
- D7. Remove the Temperature Control Thermal Element from the Thermal Well Bushing (81) in the Heater top head. Be careful not to damage the Element or its capillary.
- D8. Disconnect ALL external piping from the Heater top head, including that to that to the Relief Valve(s) (73) and the Water Solenoid Valve (79). Disconnect the Hot Water outlet piping at the union located beyond the outside diameter of the Heater top head.
- D9. Disconnect the power supply wiring to the Control Box and all wiring between the Control Box and the Solenoid Valve(s).
- D10. If an air-operated Control Valve has been furnished with the Heater, disconnect the air supply and control air piping from the Control Box.
- D11. Close the Shutoff Cock (90) in the Pressure Gage line and disconnect the Compression Fitting (86).
- D12. Disconnect the Compression Fitting (77), located at the bottom of the Shunt Tubing (87), from the Heater bottom head.
- D13. Mark the edge of the Heater bottom head flanges in order to indicate their correct relative positions upon reassembly.
- D14. Remove the Nuts (51), Studs (53) & (62), and Lockwashers (65) from the Heater bottom head flanges.
- D15. Using a hoist or block and tackle attached to the Lifting Lugs (52) on the Heater top head, CAREFULLY lift the top head and shell STRAIGHT UP off the Heater riser and coil assembly. DO NOT SCRAPE the shell lining against the coil tubing.
- D16. Clean and inspect the inside of the shell and the Steam riser/Condensate return/coils assembly for obvious damage.
- D17. With the Condensate return stop valves closed, open the stop valve(s) in the Steam inlet line to allow Steam to the Heater. Any leak in the coils, Steam riser, or Condensate return will become visible quickly. Note where the leaks are and shut off the Steam.
- D18. If a coil must be replaced, use a 1-5/16" open end wrench to disconnect the unions holding the coils to the Steam riser and Condensate return. Be careful not to damage the spud threads (see Figure HE-104-13).
- D19. If either the Steam riser or Condensate return must be replaced, it is recommended that the Heater be reassembled and returned to the AERCO factory for the replacement. (AERCO has the proper factory setup, pressure testing equipment, ready access to any needed additional parts, and the expertise necessary to provide a guaranteed replacement.) Contact the nearest AERCO Representative for instruction for making the return.
- If, however, returning the Heater to the AERCO factory is impractical, field replacement may be made but cannot be guaranteed by AERCO. If this decision is made, proceed as follows:
- Remove all coils per Step D18 above. Examine each coil carefully to make sure that replacement at this time is not an advisable action.
 - Remove the damaged Steam riser or Condensate return.
- D20. If the shell copper liner has been damaged, reassemble the Heater and return it to the AERCO factory for replacement of the liner. Contact the nearest AERCO Representative for instruction for making the return.
- D21. If it is necessary for any reason to remove the Heater top Head (37) from the Shell (58):
- Remove Temperature Gage and Temperature Switch Thermal Elements from their locations in the Heater top head.
 - Remove the Nuts (51), Studs (53) and (62), and Lifting Lugs (Eye Bolts) (52), and lift the Head off the Shell.
 - Inspect, repair, or replace any of the Anticipator assembly (see Section A-A in Figure HE-104-16) which may have been damaged.

REASSEMBLY

Reference Illustrations:

- Same as for DISASSEMBLY above, plus
- HE-104-12 Alignment of Steam Riser and Condensate Return
 - HE-104-13 Assembly of Coil to Steam Riser or Condensate Return
 - HE-104-14 Coil Spacing Tool

Special Tool Required: Same as for DISASSEMBLY above plus a coil spacing tool as shown in Figure HE-104-14.

To Reassemble Check Valve

See Figure HE-104-11.

- R1. Insert the Valve Plug (36), the Washer (35), the Spring (34), and the Gasket (32). AERCO recommends that a new Gasket (32) be used whenever the Check Valve is reassembled.
- R2. Insert the Spring Plate Assembly (33), taking care to center it as closely as possible.
- R3. Line up the Outlet Flange (31) on the Studs (50) in the Heater top Head, making sure that the Spring Plate Assembly (33) is centered in its groove in the bottom of the Outlet Flange (31).
- R4. Replace the Nuts (51) and tighten the Outlet Flange (31) leak-tight to the Heater top head.
- R5. If this is the only reassembly operation, reconnect the Heater hot water outlet piping union and place the Heater back into operation in accordance with Steps OP1, OP12, and OP13 under OPERATING PROCEDURES above.

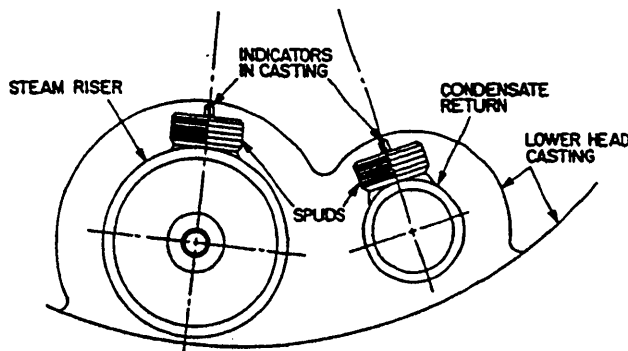

Figure HE-104-12 -- Alignment of Steam Riser and Condensate Return

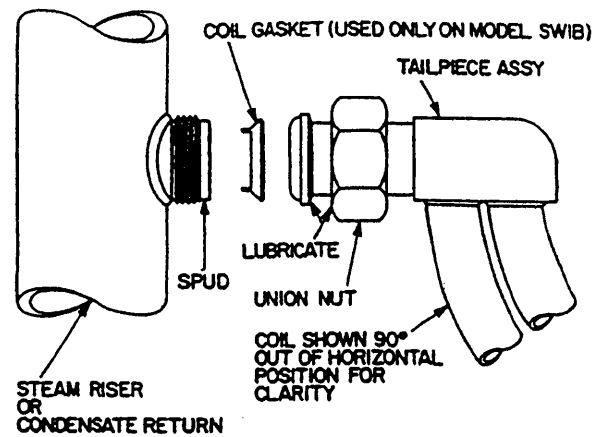

Figure HE-104-13 -- Assembly of Coil to Steam Riser or Condensate Return

To Reassemble Heater Shell

NOTE that all part item numbers given in parentheses () in the instructions below refer to those shown in Figure HE-104-15, HE-104-16, HE-104-17, or HE-104-18.

- R6. If either the Steam riser (59) or Condensate return (60) must be replaced:
 - a. Use pipe joint compound or Teflon tape on threads and screw the replacement Steam riser and/or Condensate return into the Heater bottom head.
 - b. Turn the riser and/or return in leak tight, but carefully line up the spud centers with the raised indicators on the bosses in the bottom head casting as shown in Figure HE-104-12.
- R7. If a coil must be replaced:
 - a. See Figure HE-104-13. A conical Coil Gasket (57) is required for each coil union in the Heater. It is recommended that Coil Gaskets (57) be replaced whenever a coil is reassembled to a riser or return even though the coil itself is not being replaced. Snug the gasket into the riser or return spud.
 - b. Before assembling the coils to the riser or return spuds, wrap each spud with Teflon tape and apply a lubricant (grease) to the back of the union nuts and shoulders on the coil tail pieces (see Figure HE-104-13). Rotate the nuts to spread the grease.
 - c. Assemble the coil union to the Condensate return first. Do not tighten. Assemble the other coil union to the Steam riser.

- d. Using a torque wrench, tighten both unions to approximately 75 ft-lb while holding the coil so that the turns of the coil remain perfectly horizontal, where they are brazed to the tail pieces, after tightening.
NOTE: Never use a hammer on a wrench to tighten a union nut. Deformation and subsequent leaking may result.
- e. Space the coil tubes evenly throughout the Heater, with each tube space at least 1/2" wide. It is especially important that no tubes rest on any coil unions. A spacing tool may be made up similar to that shown in Figure HE-104-14 (available from AERCO, Part No. 12523). Insert the tool flat between the coil tubes and twist the tool until the desired spacing is obtained.
- f. Test for leaks in accordance with Step D17 above under DISASSEMBLY. Make any corrections necessary.
- R8. Clean all gaskets and gasket surfaces thoroughly. AERCO recommends that new Gaskets (54) be used whenever reassembling either the top or bottom head to the shell.
- R9. If the Heater top Head (37) has been removed from the Shell (58):
- Clean the gasket surfaces thoroughly and place a Gasket (54) (a new gasket is recommended) on the shell top flange.
 - Replace the Heater top head and Anticipator assembly into the top of the shell, lining up the stud holes.
 - Reassemble the Studs (53) and (62), the Lifting Lugs (Eye Bolts) (52), and Nuts (51) into the head and shell flanges. Cross-tighten the Nuts to approximately 75 ft-lb torque to obtain uniform seating. Then progressively tighten the Nuts to approximately 150 ft-lb torque for a tight seal.
 - Replace the Temperature Gage and Temperature Switch Thermal Elements into their locations in the Heater top head.
- R10. Place the Gasket (54) on the Heater bottom head flange.
- R11. Using a hoist or block and tackle attached to the Lifting Lugs (52) on the Heater top Head (37), CAREFULLY lower the top head and shell STRAIGHT DOWN over the coil and riser assembly. DO NOT SCRAPE the shell lining against the coil tubing.
- R12. Before resting the shell flange onto the bottom head flange, make sure that the shell is positioned properly by lining up the marking put on the edges of the flanges in Step D13 under DISASSEMBLY above. For further assurance, see that the raised indicators on the outside diameters of each of the top and bottom head
- flanges line up with each other. This is very important.
- R13. Assemble the Studs (53) and (62), Lockwashers (65), and Nuts (51) into the bottom head and shell flanges. Tighten the Nuts in the same manner as in Step R9c above.
- R14. Reconnect the Compression Fitting (77), located at the bottom of the Shunt Tubing (87), to the bottom Heater head.
- R15. Reconnect the Compression Fitting (86) at the end of the Pressure Gage line and open the Shutoff Cock (90).
- R16. If an air-operated Control Valve has been furnished with the Heater, reconnect the air supply and control air piping to the Control Box.
- R17. Reconnect the power supply wiring to the Control Box and all wiring between the Control Box and Solenoid Valve(s).
- R18. Reconnect all external piping to the Heater top head, including that to the Relief Valve(s) (73) and the Water Solenoid Valve (79).
- R19. Replace the Temperature Thermal Element into the Thermal Well Bushing (81) in the Heater top head. Be careful not to damage the Element or its capillary.
- R20. Refill and place the Heater back into operation in accordance with Steps OP1, OP12, and OP13 under OPERATING PROCEDURES above.

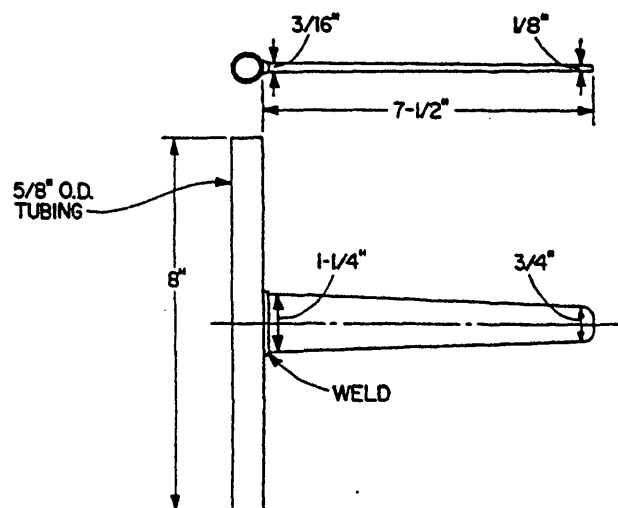

Figure HE-104-14 -- Coil Spacing Tool

RECOMMENDED SPARE PARTS

| <u>Quantity Per Heater</u> | <u>Item No.</u> | <u>Part Name</u> | <u>Shown in Figure No.</u> |
|---------------------------------------|-----------------|------------------------|--------------------------------|
| <u>For any MODEL SW1B-PLUS Heater</u> | | | |
| 1 | 3 | Dial Thermometer | HE-104-15 |
| 1 | 5 | Temperature Switch | HE-104-15 |
| 1 | 12 | Compound Pressure Gage | HE-104-15 |
| 1 | 24 | Green Indicator Light | HE-104-15 |
| 1 | 25 | Red Indicator Light | HE-104-15 |
| 2 | 32 | Outlet Flange Gasket | HE-104-16 |
| 4 | 54 | Head Gasket | HE-104-16 |
| * | 56 | Coil Assembly | HE-104-16 |
| ** | 57 | Conical Coil Gasket | HE-104-16 |

* Minimum of 2 to a maximum of the number in your largest Heater

** 2 per Spare Coil Assembly, Item 56, plus 2

For MODEL SW1B-PLUS Heater with Air-Operated Control Valve

| | | | |
|---|----|----------------------------|-----------|
| 1 | 2 | Temperature Controller | HE-104-15 |
| 1 | 11 | Air Solenoid Valve | HE-104-15 |
| 1 | 73 | P&T Relief Valve*** | HE-104-17 |
| 1 | 79 | Water Solenoid Valve | HE-104-17 |
| 2 | 97 | Asbestos Flange Gasket**** | HE-104-17 |

For MODEL SW1B-PLUS Heater with Self-Contained Control Valve

| | | | |
|---|----|---|-----------|
| 1 | 73 | P&T Relief Valve*** | HE-104-18 |
| 1 | 79 | Water Solenoid Valve | HE-104-18 |
| 1 | 84 | Steam Solenoid Valve | HE-104-18 |
| 2 | 97 | Asbestos Flange Gasket**** | HE-104-18 |
| 1 | -- | Control Valve Thermal Element, AERCO Part No. 5144-1 | HE-104-18 |

*** See Table 2 in Figure HE-104-17 or HE-104-18 for correct size and Part No. of P&T Relief Valve required

**** For Heaters with Control Valves 2-1/2" and larger

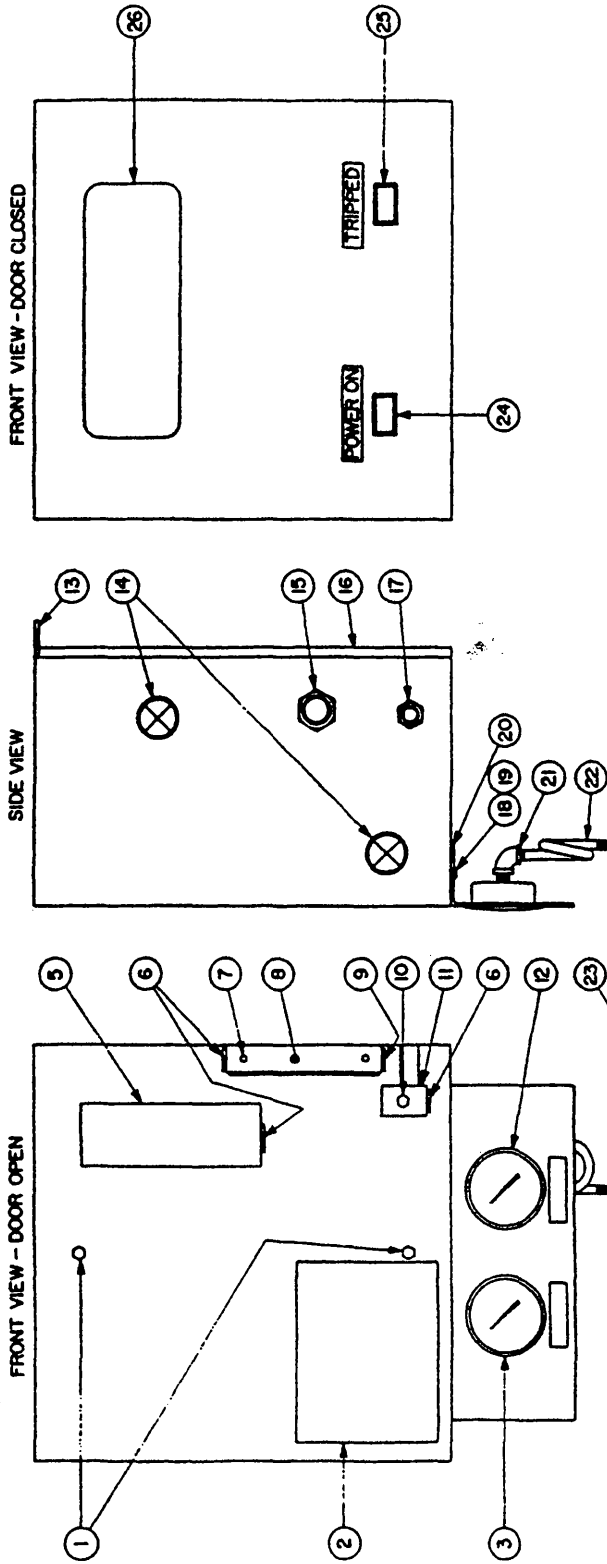

CONTROL BOX PARTS COMMON TO ANY B-PLUS HEATER

| ITEM NO. | QUAN. REQ'D | PART NAME | PART NO. |
|----------|-------------|--|----------|
| 1 | 2 | BRACKET MOUNTING SCREWS | 6-210 |
| 3 | 1 | 2-1/2" DIAL THERMOMETER | 12953 |
| 5 | 1 | TEMPERATURE SWITCH AQUASTAT MODEL L6008A | 5131-1 |
| 6 | 2 | HEYCO BUSHING UB-875 | 12951 |
| 7 | 4 | PLUGS | 122183 |
| 8 | 1 | ELECTRICAL JUNCTION BOX | 121299 |
| 9 | 2 | HEYCO BUSHING UB-625 | 122184 |
| 12 | 1 | 2-1/2" DIAL COMPRESS. GAGE | 121602 |
| 13 | 1 | BOX MOUNTING BRACKET | 16967 |
| 14 | 1 | HEYCO BUSHING UB-750 | 12952 |

BOTTOM VIEW

CONTROL BOX PARTS FOR B-PLUS HEATERS WITH AIR-OPERATED CONTROL VALVE

| ITEM NO. | QUAN. REQ'D | PART NAME | PART NO. |
|----------|-------------|--|----------|
| 2 | 1 | TEMPERATURE CONTROLLER BARBER COLMAN PK-8124-103 | 18557 |
| 4 | 1 | SPLIT BUSHING | 121959 |
| 6 | 1 | HEYCO BUSHING UB-875 | 12951 |
| 10 | 2 | 1/4" TUBE x 1/8" NPT 90° COMP. FITTING | 8-40 |
| 11 | 1 | AIR SOLENOID VALVE ASCO CAT. NO. 8320-B3 | 9637 |
| 14 | 1 | HEYCO BUSHING UB-750 | 12952 |
| 17 | 1 | 1/4" BULKHEAD UNION CONN. | 8-37 |

| ITEM NO. | QUAN. REQ'D | PART NAME | PART NO. |
|----------|-------------|-------------------------------|----------|
| 15 | 2 | 3/8 x 1/2" CONDUIT CONN. | 122103 |
| 16 | 1 | CONTROL BOX | 20764 |
| 18 | 2 | 10-32 x 3/8" LG. MACH. SCREWS | 6-288 |
| 19 | 2 | 10-32 NUTS | 6-223 |
| 20 | 1 | GAGE MOUNTING BRACKET | 18780 |
| 21 | 1 | 1/4" NPT 90° ELBOW | 9-461 |
| 22 | 1 | 1/4" NPT PIGTAIL | 8-20 |
| 23 | 1 | VENT PLUG | 122185 |
| 24 | 1 | GREEN INDICATOR LIGHT | 121949 |
| 25 | 1 | RED INDICATOR LIGHT | 121948 |
| 26 | 1 | AERCO LOGO LABEL | 12869 |

FOR CONTROL BOX WIRING DIAGRAM, SEE FIGURE HE-104-10 IN AERCO INSTRUCTION HE-104 OR AERCO DRAWING SD-A-336.

Figure HE-104-15 -- AERCO Model SW1B-PLUS Control Box -- Assembly and Parts List

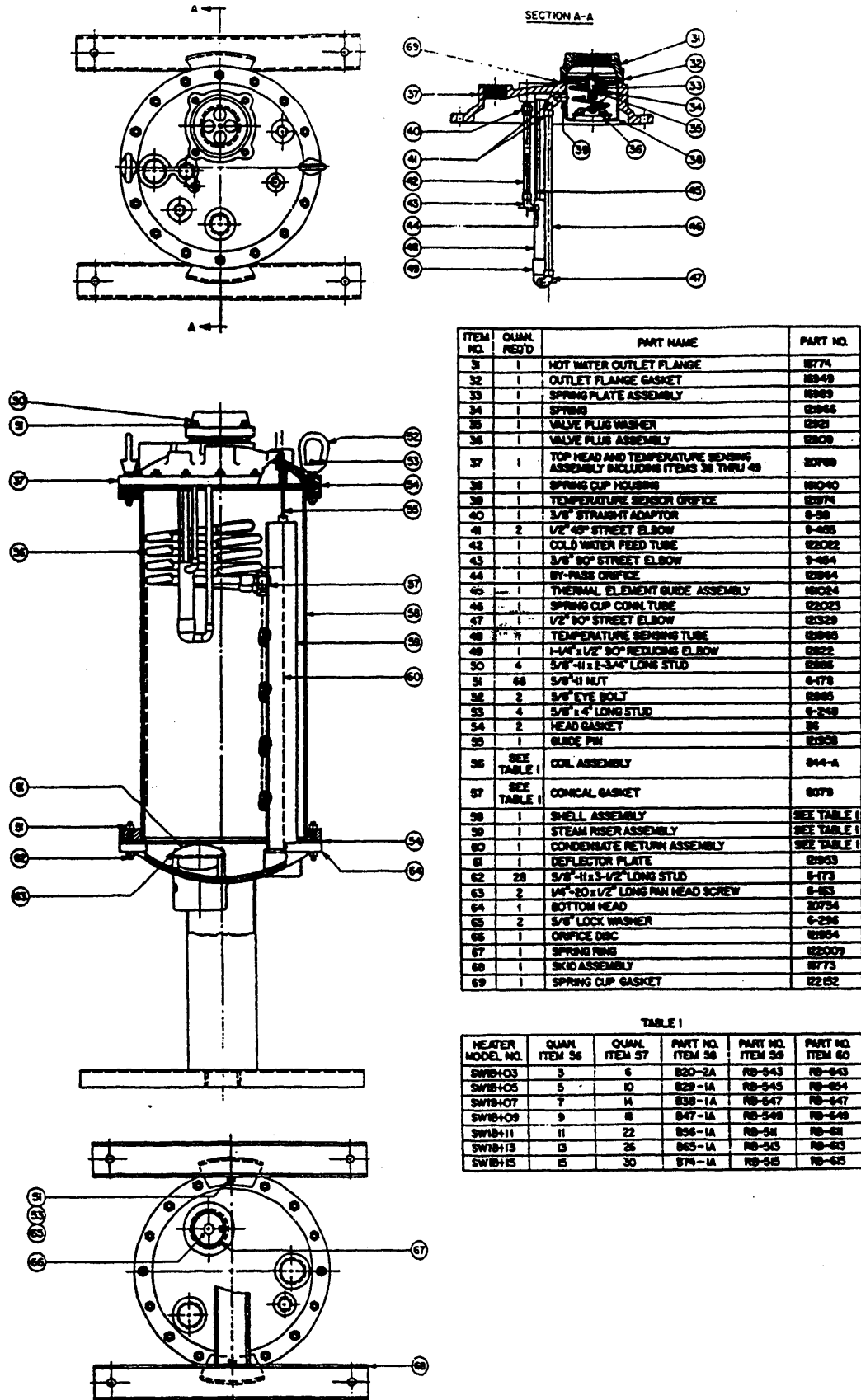

| ITEM NO. | QUAN. REQ'D | PART NAME | PART NO. |
|----------|-------------|--|-------------|
| 31 | 1 | HOT WATER OUTLET FLANGE | 18774 |
| 32 | 1 | OUTLET FLANGE GASKET | 18849 |
| 33 | 1 | SPRING PLATE ASSEMBLY | 18989 |
| 34 | 1 | SPRING | 18986 |
| 35 | 1 | VALVE PLUG WASHER | 18921 |
| 36 | 1 | VALVE PLUG ASSEMBLY | 18908 |
| 37 | 1 | TOP HEAD AND TEMPERATURE SENSING ASSEMBLY INCLUDING ITEMS 38 THRU 49 | 30788 |
| 38 | 1 | SPRING CLIP HOUSING | 18040 |
| 39 | 1 | TEMPERATURE SENSOR ORIFICE | 18974 |
| 40 | 1 | 3/8" STRAIGHT ADAPTOR | 8-38 |
| 41 | 2 | 1/2" 45° STREET ELBOW | 8-405 |
| 42 | 1 | COLD WATER FEED TUBE | 18282 |
| 43 | 1 | 3/8" 90° STREET ELBOW | 8-464 |
| 44 | 1 | BY-PASS ORIFICE | 18964 |
| 45 | 1 | THERMAL ELEMENT GUIDE ASSEMBLY | 18024 |
| 46 | 1 | SPRING CLIP CONN. TUBE | 18203 |
| 47 | 1 | 1/2" 90° STREET ELBOW | 18329 |
| 48 | 1 | TEMPERATURE SENSING TUBE | 18985 |
| 49 | 1 | 1-1/4" x 1/2" 90° REDUCING ELBOW | 18222 |
| 50 | 4 | 5/8" -11 x 2-3/4" LONG STUD | 18986 |
| 51 | 68 | 5/8"-11 NUT | 8-173 |
| 52 | 2 | 3/8" EYE BOLT | 18985 |
| 53 | 4 | 5/8" 1-4" LONG STUD | 8-348 |
| 54 | 2 | HEAD GASKET | 36 |
| 55 | 1 | GUIDE PIN | 18908 |
| 56 | SEE TABLE I | COIL ASSEMBLY | 844-A |
| 57 | SEE TABLE I | CONICAL GASKET | 8079 |
| 58 | 1 | SHELL ASSEMBLY | SEE TABLE I |
| 59 | 1 | STEAM RISER ASSEMBLY | SEE TABLE I |
| 60 | 1 | CONDENSATE RETURN ASSEMBLY | SEE TABLE I |
| 61 | 1 | DEFLECTOR PLATE | 18993 |
| 62 | 28 | 5/8"-11 x 3-1/2" LONG STUD | 8-173 |
| 63 | 2 | 1/4"-20 x 1/2" LONG PHN HEAD SCREW | 8-853 |
| 64 | 1 | BOTTOM HEAD | 18754 |
| 65 | 2 | 5/8" LOCK WASHER | 8-296 |
| 66 | 1 | ORIFICE DISC | 18964 |
| 67 | 1 | SPRING RING | 182009 |
| 68 | 1 | SKID ASSEMBLY | 18773 |
| 69 | 1 | SPRING CLIP GASKET | 18252 |

TABLE I

| HEATER MODEL NO. | QUAN. ITEM 56 | QUAN. ITEM 57 | PART NO. ITEM 58 | PART NO. ITEM 59 | PART NO. ITEM 60 |
|------------------|---------------|---------------|------------------|------------------|------------------|
| SW1B-H03 | 3 | 6 | 820-2A | RB-543 | RB-643 |
| SW1B-H05 | 5 | 10 | 829-1A | RB-545 | RB-654 |
| SW1B-H07 | 7 | 14 | 838-1A | RB-547 | RB-647 |
| SW1B-H09 | 9 | 18 | 847-1A | RB-549 | RB-649 |
| SW1B-H11 | 11 | 22 | 856-1A | RB-541 | RB-651 |
| SW1B-H13 | 13 | 26 | 865-1A | RB-543 | RB-653 |
| SW1B-H15 | 15 | 30 | 874-1A | RB-545 | RB-655 |

Figure HE-104-16 -- AERCO Model SW1B-PLUS Heat Exchanger -- Assembly and Parts List

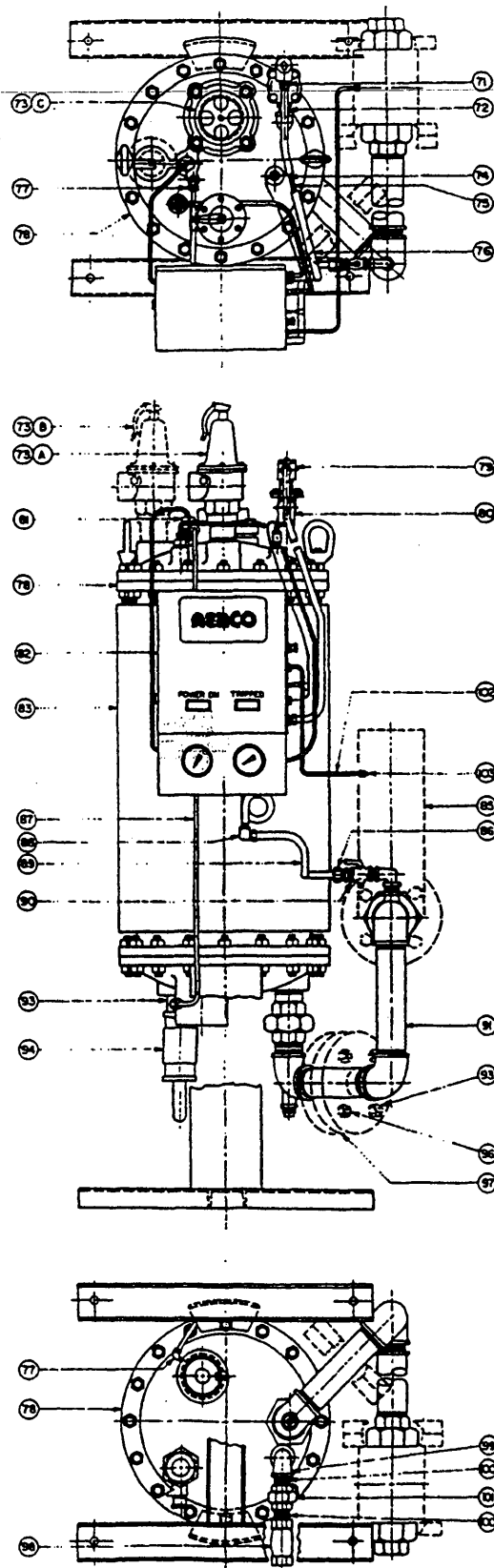

| ITEM NO. | QUAN. REQ'D | PART NAME | AERCO PART NO. |
|----------|-------------|---|----------------|
| 71 | 1 | 3/8" x 1/2" HL.B. ST. CONDUIT CONNECTOR | 8-38 |
| 72 | 1 | 1/2" x 4" LG. NIPPLE | 9-459 |
| 73 | A/R | RELIEF VALVE | SEE TABLE 2 |
| 74 | A/R | 14 GA. WHITE STRANDED WIRE | RM4523 |
| 75 | A/R | 14 GA. BLACK STRANDED WIRE | RM4524 |
| 76 | A/R | 3/8" TYPE L7 CONDUIT | RM2000 |
| 77 | 2 | 1/4" NPT x 1/2" OD TUBE 90° COMPRESSION FITTING | 8867 |
| 78 | 1 | 9-PLUS HEATER ASSEMBLY (SEE FIGURE HE-104-15) | 20788 |
| 79 | 1 | 1/2" WATER SOLIDID VALVE AERCO CAT. NO. 8292CT | 934 |
| 80 | 1 | 1/2" NPT 90° STREET ELL | 9-336 |
| 81 | 1 | THERMAL WELL, 2-1/2" DIA. | 943 |
| 82 | 1 | CONTROL BOX ASSEMBLY (SEE FIGURE HE-104-15) | 18778 |
| 83 | 1 | INSULATION | 18777 |
| 85 | 1 | AIR-OPERATED CONTROL VALVE | SEE TABLE 1 |
| 86 | 1 | 3/8" OD TUBE x 1/4" NPT MALE COMPRESSION FITTING | 8-6 |
| 87 | A/R | 1/2" TYPE K COPPER TUBING | RM4001 |
| 88 | 1 | 3/8" OD TUBE x 1/4" NPT FEMALE 90° COMPRESS FITTING | 8-43 |
| 89 | A/R | 3/8" OD TYPE L COPPER TUBING | RM4041 |
| 90 | 1 | 1/4" NPT FEMALE TO MALE SHUTOFF COCK | 81873 |
| 91 | 1 | STEAM INLET ASSEMBLY | SEE TABLE 1 |
| 93 | 1 | 2" NPT CLOSE NIPPLE | 9-297 |
| 94 | 1 | 2" NPT BALL VALVE | 8280-5 |
| 95 | 16 | 5/8"-6 NUT | 8-178 |
| 96 | 8 | 5/8"-8 STD. x 4" LONG | 8-248 |
| 97 | 2 | 1/8" THICK COMPRESSED ASBESTOS FLANGE GASKET | SEE TABLE 1 |
| 98 | 1 | 1" CHECK VALVE | 8787 |
| 99 | 1 | 1" NPT STREET ELL | 9-328 |
| 100 | 2 | 1" NPT CLOSE NIPPLE | 9-308 |
| 101 | 1 | 1" BRICE UNION | 8001 |
| 102 | A/R | 1/4" BIFOLDED TUBING | RM3041 |
| 103 | 1 | 1/4" x 1/8" NPT 90° BIFOLDED COMPRESSION FITTING | 8-40 |

NOTE - A/R = AS REQUIRED.

| VALVE SIZE | VALVE TYPE | ITEM NO. 85 | ITEM NO. 87 |
|------------|------------|-------------|-------------|
| 1" THRU 2" | OCT-P | 8782 | --- |
| 2-1/2" | OCT-P | 8983 | 4-32 |
| 3" | OCT-P | 8984 | 4-35 |
| 4" | OCT-P | 8985 | 4-38 |

PLUS NECESSARY FITTINGS & ADAPTORS

| PACKAGE PART NO. | Ⓐ CORN. 1/2" NPT | Ⓑ CORN. 1/2" NPT | Ⓒ CORN. 3/4" NPT |
|------------------|--------------------------------------|--------------------------------------|--|
| 22030-1 | 1" VALVE PT. NO. 6461 W/FITTINGS | 1-1/2" PLUS PT. NO. 9-82 | --- |
| 22030-2 | 1-1/2" VALVE PT. NO. 6462 W/FITTINGS | 1-1/2" PLUS PT. NO. 9-82 | --- |
| 22030-3 | 1-1/2" VALVE PT. NO. 6462 W/FITTINGS | 1" VALVE PT. NO. 6461 W/FITTINGS | --- |
| 22030-4 | 1-1/2" VALVE PT. NO. 6462 W/FITTINGS | 1-1/2" VALVE PT. NO. 6462 W/FITTINGS | --- |
| 22030-5 | 1-1/2" VALVE PT. NO. 6462 W/FITTINGS | 1-1/2" VALVE PT. NO. 6462 W/FITTINGS | 1-1/2" VALVE PT. NO. 6462 FOR LOCATION IN HEATER OUTLET PIPING |

AERCO PT. NO. 6461 - WRTTS NO. 10240X
 AERCO PT. NO. 6462 - WRTTS NO. 340 MODEL 3

Figure HE-104-17 -- AERCO Model SW1B-PLUS Packaged Water Heater with Air-Operated Steam Control Valve Assembly and Parts List

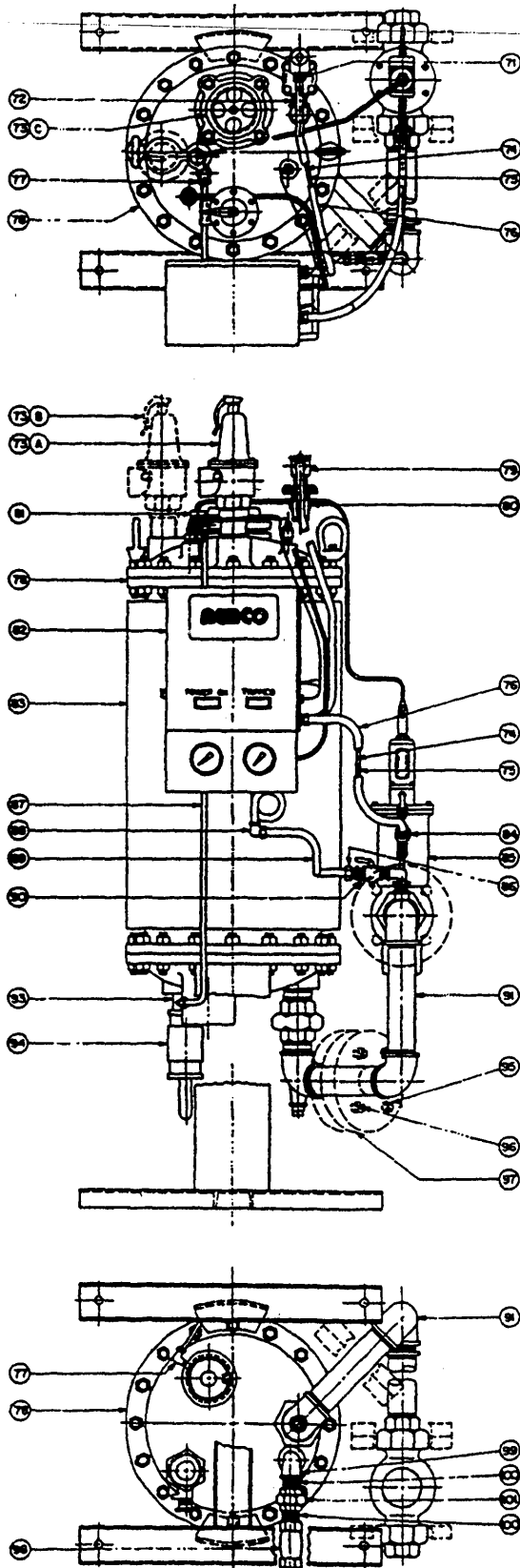

| ITEM NO. | QUAN. | REQ'D | PART NAME | AERCO PART NO. |
|----------|-------|-------|--|----------------|
| 71 | 1 | | 3/8" 1/2" NUB ST. CONDUIT CONNECTOR | 9-38 |
| 72 | 1 | | 1/2" 1/2" L.B. NIPPLE | 9-499 |
| 73 | A/R | | RELIEF VALVE | SEE TABLE 2 |
| 74 | A/R | | 1/4" O.D. WHITE STRANDED WIRE | FM4825 |
| 75 | A/R | | 1/4" O.D. BLACK STRANDED WIRE | FM4824 |
| 76 | A/R | | 3/8" TYPE LT CONDUIT | FM8000 |
| 77 | 2 | | 1/4" NPT x 1/2" OD TUBE 90° COMPRESSION FITTING | 8267 |
| 78 | 1 | | 8-PLUS HEATER ASSEMBLY (SEE FIGURE HE-104-18) | 30768 |
| 79 | 1 | | 1/2" WATER SOLIDIOD VALVE AERCO CAT. NO. 82107 | 8134 |
| 80 | 1 | | 1/2" NPT 90° STREET ELL | 9-336 |
| 81 | 1 | | THERMAL WELL BUSHING | 9443 |
| 82 | 1 | | CONTROL BOX ASSEMBLY (SEE FIGURE HE-104-8) | 9779 |
| 83 | 1 | | INSULATION | 18777 |
| 84 | 1 | | 1/4" STEAM SOLENOID VALVE AERCO CAT. NO. T8222A70 | 8352 |
| 85 | 1 | | SELF-CONTAINED CONTROL VALVE | SEE TABLE 1 |
| 86 | 1 | | 3/8" OD TUBE x 1/4" NPT MALE COMPRESSION FITTING | 9-6 |
| 87 | A/R | | 1/2" OD TYPE K COPPER TUBING | FM3031 |
| 88 | 1 | | 3/8" OD TUBE x 1/4" NPT FEMALE 90° COMPRESSION FITTING | 9-63 |
| 89 | A/R | | 3/8" OD TYPE L COPPER TUBING | FM3041 |
| 90 | 1 | | 1/4" NPT FEMALE TO MALE SHUTOFF COCK | 82175 |
| 91 | 1 | | STEAM INLET ASSEMBLY | SEE TABLE 1 |
| 93 | 1 | | 2" NPT CLOSE NIPPLE | 9-297 |
| 94 | 1 | | 2" NPT BALL VALVE | 18282-03 |
| 95 | 8 | | 5/8" NUT | 6-178 |
| 96 | 8 | | 5/8" NUT STUD x 4" LONG | 6-248 |
| 97 | 2 | | 1/4" THICK COMPRESSED ASBESTOS FLANGE GASKET | SEE TABLE 1 |
| 98 | 1 | | 1" CHECK VALVE | 82757 |
| 99 | 1 | | 1" NPT STREET ELL | 9-328 |
| 100 | 2 | | 1" NPT CLOSE NIPPLE | 9-308 |
| 101 | 1 | | 1" ORIFICE UNION | 5001 |

NOTE - A/R=AS REQUIRED

| VALVE SIZE | VALVE TYPE | ITEM NO. 91 | ITEM NO. 93 |
|------------|------------|-------------|------------------------------------|
| 1" FNPT 2" | CXT-8 | 8762 | PLUS NECESSARY FITTINGS & ADAPTORS |
| 2-1/2" | CXT-8 | 8893 | 4-32 |
| 3" | CXT-8 | 8894 | 4-35 |
| 4" | CXT-8 | 8895 | 4-38 |

| PACKAGE PART NO. | (A) CONN. 1-1/2" NPT | (B) CONN. 1-1/2" NPT | (C) CONN. 3" NPT |
|------------------|--------------------------------------|--------------------------------------|--|
| 82030-1 | 1" VALVE PT. NO. 6461 W/FITTINGS | 1-1/2" PLUR PT. NO. 9-82 | --- |
| 82030-2 | 1-1/2" VALVE PT. NO. 6462 W/FITTINGS | 1-1/2" PLUR PT. NO. 9-82 | --- |
| 82030-3 | 1-1/2" VALVE PT. NO. 6462 W/FITTINGS | 1" VALVE PT. NO. 6461 W/FITTINGS | --- |
| 82030-4 | 1-1/2" VALVE PT. NO. 6462 W/FITTINGS | 1-1/2" VALVE PT. NO. 6462 W/FITTINGS | --- |
| 82030-5 | 1-1/2" VALVE PT. NO. 6462 W/FITTINGS | 1-1/2" VALVE PT. NO. 6462 W/FITTINGS | 1-1/2" VALVE PT. NO. 6462 FOR LOCATION IN HEATER OUTLET PIPING |

AERCO PT. NO. 6461-WATTS NO. M240X
AERCO PT. NO. 6462-WATTS NO. 340 MODEL 3

Figure HE-104-18 -- AERCO Model SW1B-PLUS Packaged Water Heater with Self-Contained Steam Control Valve Assembly and Parts List

THIS PAGE LEFT BLANK INTENTIONALLY.