



User Manual

Modbus Communications

Installation, Operation, and Maintenance

Applies to:

- C-More Controller
- Boiler Management System (BMS/BMS II)
- AERCO Control System (ACS)

Other AERCO Communication Manuals:

- OMM-0032, GF-112, C-More Controller Installation, Operation & Configuration
- OMM-0080, GF-129, ProtoNode LER-RER User Manual
- OMM-0081, GF-131, ACS AERCO-Control-System User Manual
- OMM-0107, GF-150, ProtoNode FPC N34-N35 User Manual

Disclaimer

The information contained in this manual is subject to change without notice from AERCO International, Inc. AERCO makes no warranty of any kind with respect to this material, including, but not limited to, implied warranties of merchantability and fitness for a particular application. AERCO International is not liable for errors appearing in this manual, not for incidental or consequential damages occurring in connection with the furnishing, performance, or use of these materials

TABLE OF CONTENTS

TABLE OF CONTENTS	2
CHAPTER 1. INTRODUCTION AND GENERAL DESCRIPTION.....	4
1.1 INTRODUCTION.....	4
1.2 AERCO BMS AND C-MORE CONTROLLER MODELS COVERED	4
1.3 MINIMUM MODBUS SUPPORT REQUIREMENTS	4
1.3.1 Communication Medium.....	5
1.3.2 Address Support	6
1.3.3 Modbus Transmission Modes.....	6
1.3.4 Timing Specifications	6
1.4 MODBUS FUNCTION SET SUPPORT	7
1.5 EXCEPTION RESPONSES	8
1.6 PHRASES, ABBREVIATIONS & ACRONYMS	8
CHAPTER 2. STANDARD REGISTER ASSIGNMENTS	10
2.1 INTRODUCTION.....	10
2.1.1 Input Registers	10
2.1.2 Holding Registers	10
2.2 C-MORE BOILER CONTROLLER STANDARD REGISTER ASSIGNMENTS	11
2.2.1 C-More Boiler Controller Standard Input Register Assignments	11
2.2.2 C-More Boiler Controller Standard Holding Register Assignments	14
2.3 BMS/BMS II CONTROLLER STANDARD REGISTER ASSIGNMENTS	17
2.3.1 BMS/BMS II Controller Standard Input Register Assignments.....	17
2.3.2 BMS/BMS II Controller Standard Holding Register Assignments.....	21
2.4 ACS CONTROLLER (ONLY) STANDARD REGISTER ASSIGNMENTS	27
2.4.1 ACS Controller Standard Input Register Assignments.....	27
2.4.2 ACS Controller Standard Holding Register Assignments.....	29
CHAPTER 3. STANDARD APPLICATION OPERATIONS	36
3.1 INTRODUCTION.....	36
3.2 C-MORE CONTROLLER STANDARD APPLICATION OPERATIONS	36
3.2.1 Password Protection for Input and Holding Register Access	36
3.2.2 Direct Drive Control.....	37
3.2.3 Remote Setpoint Control	37
3.2.4 Combination Control (BMS/ACS Only)	38
3.2.5 Physical Slave Address Zero.....	38
3.3 BMS/BMS II/ACS STANDARD APPLICATION OPERATIONS.....	38
3.3.1 Password Protection for BMS/BMS II/ACS Input and Holding Register Access.....	38
3.3.2 Remote Setpoint Control of BMS/BMS II/ACS Slave By EMS Master	38
3.3.3 BMS/BMS II/ACS Master Control of C-More Slaves Via Network.....	39
3.3.4 BMS Combination Mode Boiler Control of C-More Slaves (BMS and ACS Only).....	39
CHAPTER 4. MODBUS NETWORK HARDWARE SETUP & INSTALLATION	40
4.1 INTRODUCTION.....	40
4.2 PHYSICAL MODBUS RS485 NETWORK WIRING CONNECTIONS	40
4.2.1 BMS Slave To EMS Master Wiring Connections	40
4.2.2 BMS II/ACS Slave To EMS Master Wiring Connections	44
4.2.3 BMS/BMS II/ACS Master To C-More Boiler Controller Slaves.....	47
4.2.4 C-More Slaves To BMS/BMS II/ACS or EMS Master	49
4.3 RS485 LOOP TERMINATING RESISTORS AND BIAS	49
4.3.1 BMS Terminating Resistor.....	49
4.3.2 C-More Boiler Controller Terminating Resistor and Bias	49

4.4 MODBUS NETWORK WIRING DIAGRAMS.....	53
4.4.1 Wiring Diagrams for Master EMS Controlling BMS Slaves With Legacy (PWM) Boilers	53
4.4.2 Wiring Diagram for Master BMS/BMS II/ACS Controlling Networked C-More Slaves	53
4.4.3 Wiring Diagram For EMS Master Controlling C-More Controller Slaves	53
CHAPTER 5. MODBUS SOFTWARE SETUP: C-MORE & BMS	58
5.1 INTRODUCTION.....	58
5.2 C-MORE BOILER CONTROLLER SETUP FOR MODBUS OPERATION	58
5.2.1 Monitoring and Configuration Control	59
5.2.2 Modbus Direct Drive Control and Monitoring	59
5.2.3 Modbus Remote Setpoint Control.....	59
5.3 BMS SETUP FOR OPERATION AS A SLAVE TO AN EMS MASTER	60
5.3.1 BMS Monitoring and Configuration By An EMS Master	60
5.3.2 BMS Modbus Remote Setpoint Control By An EMS Master	60
5.4 BMS SETUP AS MASTER TO C-MORE BOILER CONTROLLERS	61
CHAPTER 6. MODBUS SOFTWARE SETUP: C-MORE & BMS II/ACS	64
6.1 INTRODUCTION.....	64
6.2 C-MORE BOILER CONTROLLER SETUP FOR MODBUS OPERATION	64
6.2.1 Monitoring and Configuration Control	64
6.2.2 Modbus Direct Drive Control and Monitoring	65
6.2.3 Modbus Remote Setpoint Control.....	65
6.3 BMS II/ACS SETUP FOR OPERATION AS A SLAVE TO AN EMS MASTER.....	66
6.3.1 BMS II/ACS Monitoring and Configuration By An EMS Master	66
6.3.2 BMS II/ACS Modbus Remote Setpoint Control By An EMS Master	66
6.4 BMS II/ACS SETUP AS MASTER TO C-MORE BOILER CONTROLLERS.....	67
APPENDIX A: C-MORE REFERENCE TABLES	70

CHAPTER 1. INTRODUCTION AND GENERAL DESCRIPTION

1.1 Introduction

The information contained in this manual provides general guidelines for implementing a Modbus® communications network utilizing AERCO's Boiler Management System (BMS) Model 168, Boiler Management System II (BMS II) Model 5R5-384, or AERCO Control System (ACS) and C-More Boiler Controllers.

Throughout this document, the following terminology shall be used when referring to BMS Model 168 and BMS II Model 5R5-384:

- BMS: Applies to BMS Model 168 Only
- BMS II: Applies to BMS II Model 5R5-384 Only
- BMS/BMS II: Applies to Both Models (BMS and BMS II)
- BMS II/ACS: Applies to Both Models (BMS II and ACS)
- ACS: Applies to ACS Only

All Modbus networks are implemented utilizing a Master-Slave technique where only one device, the Master, can initiate a communication sequence. AERCO C-More Controllers can only function as Slave devices in a Modbus network. However, the AERCO BMS can function both as a Master controlling C-More Slaves, or as a Slave controlled by an Energy Management System (EMS) or Building Automation System (BAS) developed by other manufacturers.

1.2 AERCO BMS and C-More Controller Models Covered

To easily determine if your AERCO BMS or C-More Boiler Controller is equipped with Modbus capabilities, check the current software version as follows:

For BMS:

- Apply power to the BMS
- The BMS will display: **INITIALIZING** followed by **EPROM REV K**
- If **REV K** or higher is displayed, the BMS Controller can support Modbus
- If the **REV** level is lower than K, the BMS Controller cannot support Modbus

For BMS II/ACS:

- All BMS II Controllers support Modbus

For C-More:

- Apply external power to the C-More Controller
- Scroll through the Setup Menu and observe the displayed **Software Version**
- If **2.00** or higher is displayed, the C-More Controller can support Modbus
- If a **Software Version** lower than 2.00 is displayed, the C-More Controller cannot support Modbus

1.3 Minimum Modbus Support Requirements

Implementation of a Modbus communication network utilizing the AERCO C-More Controller and BMS/BMS II will be limited to the minimum support requirements listed in Table 1-1 which follows.

CHAPTER 1: Introduction And General Description

The remaining paragraphs in this Section provide more detailed descriptions for each of the items listed.

TABLE 1-1: Modbus Communication and Support Requirements	
CHARACTERISTIC	REQUIREMENT
<p><u>Communication Medium:</u></p> <p>EMS Master-To-BMS/BMS II/ACS Slave:</p> <p>BMS/BMS II/ACS Master-To-C-More Slave:</p> <p>EMS Master-To- C-More Slave:</p>	<p>RS232 (or RS485 With Optional Converter)</p> <p>RS485, 2-Wire Differential Bus With Shield</p> <p>RS485, 2-Wire Differential Bus With Shield</p>
<p><u>Allowable Cable Lengths:</u></p> <p>RS232:</p> <p>RS485:</p> <p>PWM:</p>	<p>50 Feet, Maximum</p> <p>4,000 Feet, Maximum</p> <p>1,000 Feet, Maximum</p>
<p><u>Address Support From Master:</u></p> <p>BMS/BMS II/ACS:</p> <p>C-More Controller (Slave):</p> <p>Broadcast Messages:</p>	<p>128 to 247 (From a Master EMS)</p> <p>1 to 127 (From Master BMS/BMS II/ACS or EMS)</p> <p>Address 0 is Reserved for Broadcast Messages</p>
<p><u>Transmission Mode Support</u></p>	<p>RTU (Remote Terminal Unit)</p>
<p><u>Timing Specifications:</u></p> <p>Baud Rate:</p> <p>Message Framing:</p> <p>Character Framing:</p> <p>Heartbeat Timeout:</p>	<p>Fixed at 9600 For C-More</p> <p>Adjustable For BMS/BMS II/ACS: 2400, 4800, 9600, 14.4k, 19.2k Default = 9600</p> <p>Silent period of at least 3.5 character times <u>Before</u> first character and <u>After</u> last character of message</p> <p>No more than 1.5 character times of silence between received and transmitted characters</p> <p>Fixed at 10 seconds For C-More Adjustable For BMS/BMS II/ACS: 5 to 240 Seconds</p>

1.3.1 Communication Medium

The communication medium for each of the possible Modbus network configurations may vary depending on the Master/Slave scenario being implemented. Detailed installation procedures and wiring diagrams for the configurations described in the following paragraphs are provided in Section 4 of this manual.

1.3.1.1 EMS Master To BMS/BMS II/ACS Slave

The Modbus network connections between the EMS and BMS/BMS II/ACS will depend on the type of port provide on the EMS Master. If the EMS contains a RS232 port, a direct connection can be made directly to the BMS/BMS II/ACS RS232 port. For optimum results the wire length between the EMS and BMS/BMS II/ACS RS232 connection should not exceed 50 feet. If the EMS Master contains a RS485 port, a RS485-to-RS232 converter will be required to implement the Modbus network.

1.3.1.2 BMS/BMS II/ACS Master To C-More Boiler Controller Slaves

Up to a total of 32 C-More Boiler Controllers can be connected to a BMS/BMS II/ACS Master on the Modbus Network. Multi-point drop network connections are made using shielded, twisted-pair wire. In addition to the Modbus Network Boilers, up to 8 additional Legacy Boilers can be connected to the BMS Pulse Width Modulation (PWM) wiring connection. The BMS II and ACS do not support PWM. It should be noted that the BMS, BMS II, and ACS include a Modbus Pass-Thru feature which, when enabled, permits an EMS to monitor and configure (but not directly control) the boilers.

1.3.1.3 EMS Master To C-More Boiler Controller Slaves

The number of C-More Boiler Controllers which can be connected to a Modbus Network which utilizes a third party EMS Master will depend on the EMS's limitations. Theoretically, the maximum number of Slave devices is limited to 127. If the EMS contains a RS232 port, a RS232-to-RS485 converter will be required to provide the necessary RS485 interfaces and signal levels for the C-More Boiler Controllers. Multi-drop network connections are made using shielded, twisted-pair wire.

1.3.2 Address Support

Address support is assigned as follows:

- BMS/BMS II/ACS Address Support From EMS Master: 128 – 247 (80 – F7 hex)
- C-More Address Support From BMS/BMS II/ACS or EMS Master: 1 – 127 (01 – 7F hex)
- Broadcast Messages: Address 0 is reserved for all Broadcast messages
-

1.3.3 Modbus Transmission Modes

Many Modbus Controllers can be set up to transmit using either the ASCII (American Standard Code for Information Interchange) transmission mode, or the RTU (Remote Terminal Unit) transmission mode. However, since RTU messages can be formatted using far fewer binary bits than the corresponding ASCII message, it is far more efficient. Therefore, all Modbus messages for the AERCO BMS/BMS II/ACS and C-More Boiler Controllers use RTU transmission ONLY. If a third-party EMS Master is being used in the Modbus network, ensure that it is set for RTU transmission.

1.3.4 Timing Specifications

As Table 1-1 shows, Baud Rate and Heartbeat Timeout will vary depending on the Configurations of the AERCO BMS/BMS II/ACS and C-More Boiler Controllers being used in the Modbus Network. Ensure that the Baud Rate used by the controlling Master (BMS/BMS II/ACS or EMS) matches the appropriate Baud Rate supported by the Network Slaves (BMS/BMS II/ACS or C-More Controllers). Also, ensure that the Modbus Master can refresh the control information to all C-More Slaves before the Heartbeat Timeout period expires.

1.4 Modbus Function Set Support

The complete Modbus protocol includes a total of 24 Function Codes. However, for AERCO BMS/BMS II/ACS and C-More Boiler Controllers, only the Codes listed in Table 1-2 are supported. The supported Diagnostic Sub-Function Codes associated with Diagnostic Function Code 08 are listed in Table 1-3.

Function Code	Function Name
03	Read Holding Register (Read Multiple Registers)
04	Read Input Registers
06	Preset (Write) Single Register
08	Diagnostics (See Table 1-3 for supported Sub-Function Codes)
17	Report Slave ID

Sub-Function Code	Sub-Function Name	Comments
00	Return Query Data	Loop-Back
01	Restart Communications Options	Resets the Slave. Cancels Listen Only Mode.
02	Return Diagnostic Register	Not Used
04	Force Listen Only Mode	Reset by Restart Communications Option
10	Clear Counters and Diagnostic Register	Also cleared at power up. Clears only the counters
12	Return Bus Communication Error Count	Slave CRC errors only.
13	Return Bus Exception Error Count	Slave Exception Response count.
14	Return Slave Message Count	Number of messages addressed to the slave and successfully processed. Includes broadcast messages.
15	Return Slave No Response Count	Number of messages addressed to the slave for which no response was returned.

18	Return Bus Character Overrun Count	Number of overrun and framing errors.
----	------------------------------------	---------------------------------------

1.5 Exception Responses

With the exception of Broadcast Messages, queries transmitted by the Master expect a normal response from the addressed Slave on the network. However, if the addressed Slave cannot process or interpret the message, it will respond with one of the Exception Codes listed in Table 1-4.

TABLE 1-4: Minimum Exception Code Set

Exception Code	Description	Comments
01	Illegal Function	The function code received is not valid or is not supported.
02	Illegal Data Address	The data address received is invalid or is not accessible due to security setting.
03	Illegal Data Value	The data value received is not valid

1.6 Phrases, Abbreviations & Acronyms

The phrases, abbreviations and acronyms used in this manual are listed in Table 1-5.

TABLE 1-5: Phrases, Abbreviations and Acronyms

Phrase, Abbreviation or Acronym	Meaning
ACS	AERCO Control System
ASCII	American Standard Code for Information Interchange
BAS	Building Automation System
Baud	Bits per Second (bps)
BMS (BMS II)	Boiler Management System (Boiler Management System II)
C-More Controller (or Control Box)	A control system developed by AERCO International and currently used in all Benchmark and KC Series product lines
EMS	Energy Management System
FDX	Full-Duplex
HDX	Half-Duplex
Hex	Hexadecimal Number (0 - 9, A - F)
I/O Box	Input/Output (I/O) Box currently used on all Benchmark and KC Series products
LSB	Least Significant Byte
Modbus®	A serial, half-duplex data transmission protocol developed by AEG Modicon
MSB	Most Significant Byte
RS232	A standard for serial, full-duplex (FDX) transmission of data based on the RS232 Standard

CHAPTER 1: Introduction And General Description

RS422	A standard for serial, full-duplex (FDX) transmission of data based on the RS422 Standard
RS485	A standard for serial, half-duplex (HDX) transmission of data based on the RS485 Standard
RTU	Remote Terminal Unit

CHAPTER 2. STANDARD REGISTER ASSIGNMENTS

2.1 Introduction

This Section provides the standard data register addresses assigned to the AERCO and C-More Boiler Controllers, the AERCO Boiler Management System (BMS/BMS II), and AERCO Control System (ACS). These data registers consist of Input Registers and Holding Registers. All register addresses provided throughout this manual are expressed as hexadecimal numbers.

2.1.1 Input Registers

The Input Registers for the AERCO C-More Boiler Controllers and AERCO BMS/BMS II/ACS are intended for information and functions that cannot or should not be controlled remotely. Therefore, unless otherwise specified, ALL Input Register data are READ ONLY.

IMPORTANT!

All Modbus addresses specified in this manual are written generically in decimal/hexadecimal format. However, many Building Automation Systems utilize another form of addressing where: 40001 is added to the generic address for a Holding Register address.

and

30001 is added to the generic address for an Input Register address. Be sure to check the addressing scheme being used by the BAS that is being interfaced to the XPC Gateway

2.1.2 Holding Registers

The Holding Registers for the AERCO C-More Boiler Controllers and AERCO BMS/BMS II/ACS are intended for information and functions that can be read or written (R/W). Therefore unless otherwise specified, all Holding Register data are R/W.

CAUTION:

DO NOT write in any Register Addresses marked as "Reserved" in the Input Register and Holding Register Tables which follow. Failure to observe this precaution may result in unstable operation.

2.2 C-MORE Boiler Controller Standard Register Assignments

2.2.1 C-More Boiler Controller Standard Input Register Assignments

The following table lists the Read Only Input Register addresses; Modbus Data Address in Decimal (Hex).

TABLE 2-1: C-More Boiler Controller Standard Input Register Address Mapping

Modbus Data Address	Menu Item	Units and Range	Default/ Comments
0 (0x0000)	Default Message Display Code	Enum (1 to 64)	See Appendix A, Table A-1 for listing
1 (0x0001)	Unit Status	Enum (0, 1, 2, 3, 4, 5) 0 = Unit Status Disabled 1 = Unit Status Standby 2 = Unit Status Manual 3 = Unit Status Remote 4 = Unit Status Auto 5 = Unit Status Fault	
2 (0x0002)	Outlet Temp	DEGREES_1 (0 to 1000)	See Appendix A, Tables A-2 and A-3 for Conversions
3 (0x0003)	Inlet Temp	DEGREES_1 (0 to 1000)	See Appendix A, Tables A-2 and A-3 for Conversions
4 (0x0004)	Aux Temp	DEGREES_1 (0 to 1000)	See Appendix A, Tables A-2 and A-3 for Conversions
5 (0x0005)	Outdoor Temp	DEGREES_2 (0 to 1000)	See Appendix A, Tables A-2 and A-3 for Conversions
6(0x0006)	Exhaust Temp	DEGREES_2 (0 to 1000)	See Appendix A, Tables A-2 and A-3 for Conversions
7 (0x0007)	FFWD Temp	DEGREES_1 (0 to 1000)	See Appendix A, Tables A-2 and A-3 for Conversions
8 (0x0008)	Fire Rate Out	% (0 to 100)	
9 (0x0009)	O2 Level	% (0 to 25)	
10 (0x000A)	CO Level	PPM (0 to 500)	
11 (0x000B)	Run Cycles Low (LSB)	int (0 to 65535)	The actual range for run cycles is from 0 to 999,999
12 (0x000C)	Run Cycles High (MSB)	Int (0 to 15)	
13 (0x000D)	Run Hours Low (LSB)	int (0 to 65535)	The actual range for run hours is from 0 to 999,999
14 (0x000E)	Run Hours High (MSB)	int (0 to 15)	

TABLE 2-1: C-More Boiler Controller Standard Input Register Address Mapping

Modbus Data Address	Menu Item	Units and Range	Default/ Comments
15 (0x000F)	Flame Strength	% (0 to 100)	
16 (0x0010)	Active Set point	DEGREES_1 (0 to 1000)	See Appendix A, Tables A-2 and A-3 for Conversions
17 (0x0011)	Fire Rate In	% (0 to 100)	
18 (0x0012)	Manual Fire Rate	% (0 to 100)	Only applicable when in the Manual Mode and controlled by the front panel interface
19 (0x0013)	Comm Address	Int (0 to 127)	Default = 0 Comm Address 0 disables the Controller's Modbus communications
20 (0x0014)	Software Version	int (0 to 65535)	
21 (0x0015) 22 (0x0016)	(Reserved)		
23 (0x0017)	Fault Log Code		Fault Log
24 (0x0018)	Fault Log Cycle (LOW)	int (0 to 65535)	The internal variable type for fault log display cycle is long and the range is 0 to 999999
25 (0x0019)	Fault Log Cycle (HIGH)	Int (0 to 15)	
26 (0x001A)	Fault Log Date	Int (1 to 65535) 1 count/day	
27 (0x001B)	Fault Log Time	Int (0 to 1439) 1 count/min.	
28 (0x001C)	Sensor Log Active Setpoint	DEGREES_1 (0 to 1000)	See Appendix A, Tables A-2 and A-3 for Conversions
29 (0x001D)	Sensor Log Outlet Temp	DEGREES_1 (0 to 1000)	See Appendix A, Tables A-2 and A-3 for Conversions
30 (0x001E)	Sensor Log Inlet Temp	DEGREES_1 (0 to 1000)	See Appendix A, Tables A-2 and A-3 for Conversions
31 (0x001F)	Sensor Log FFWD Temp	DEGREES_1 (0 to 1000)	See Appendix A, Tables A-2 and A-3 for Conversions
32 (0x0020)	Sensor Log Exhaust Temp	DEGREES_3 (0 to 1000)	See Appendix A, Tables A-2 and A-3 for Conversions
33 (0x0021)	Sensor Log Outdoor Temp	DEGREES_2 (0 to 1000)	See Appendix A, Tables A-2 and A-3 for Conversions
34 (0x0022)	Sensor Log Aux Temp	DEGREES_1 (0 to 1000)	See Appendix A, Tables A-2 and A-3 for Conversions
35 (0x0023)	Sensor Log CO xmitter	PPM_UNITS	
36 (0x0024)	Sensor Log O2 xmitter	% (0 to 100)	

TABLE 2-1: C-More Boiler Controller Standard Input Register Address Mapping

Modbus Data Address	Menu Item	Units and Range	Default/ Comments
37 (0x0025)	Sensor Log Flow Meter	GPM_UNITS	
38 (0x0026)	Time Log Status	73 ("I") = Ignition 74 ("O") = Off 80 ("P") = Power Up 82 ("R") = Run	
39 (0x0027)	Time Log Fire Rate	% (0 to 100)	
40 (0x0028)	Time Log Flame Strength	% (0 to 100)	
41 (0x0029)	Time Log Run Length	Int (0 to 65535)	
42 (0x002A)	Time Log Date	Int (0 to 65535) 1 count/day	
43 (0x002B)	Time LogTime	Int (0 to 1439) 1 count/min.	

2.2.2 C-More Boiler Controller Standard Holding Register Assignments

The following table lists the Read/Write Input Register address assignments; Modbus Data Address in Decimal (Hex). Unless otherwise specified, all Holding Register menu items are Read/Write (R/W)

TABLE 2-2: C-More Controller Standard Holding Register Address Mapping			
Modbus Data Address	Menu Item	Units and Range	Comments
0 (0x0000)	Net Remote Set Point	DEGREES_1 (0 to 1000)	See Appendix A, Tables A-2 and A-3 for Conversions. R/W ONLY in Remote Set Point Mode
1 (0x0001)	Net Direct Drive	% (0 to 100)	Normally Read Only. R/W ONLY in Direct Drive Mode.
2 (0x0002)	Modbus Password	int (0 to 65535)	Default = 0
3 (0x0003)	Password	int (0 to 65535)	Default = 0
4 (0x0004)	Internal Set Point	DEGREES_1 (0 to 1000)	See Appendix A, Tables A-2 and A-3 for Conversions Default = 130°F
5 (0x0005)	(Reserved)		
6 (0x0006)	Time	Int (0 to 1439) 1count/min	
7 (0x0007)	Date	int (0 to 65535) 1count/day	Date count starts with Jan. 1, 2000. For Example: Jan. 1 2001 would equal 365 counts
8 (0x0008)	Unit of Temp	bool (0, 1) 0= Degrees Fahrenheit (°F) 1=Degrees Celsius (°C)	Default = °F
9 (0x0009)	Baud Rate	enum (0, 1, 2, 3, 4) 0 = 2.4k 1 = 4.8k 2 = 9.6k 3 = 19.2k	For C-More RS232 port ONLY Default = 2 (9.6k)
10 (0x000A)	Unit Type	bool (0, 1) 0 = Boiler 1 = Water Heater	Default = Boiler
11 (0x000B)	Unit Size	enum (0, 1, 2, 3, 4, 5) 0 = 0.5 MBTU 1 = 1 MBTU 2 = 1.5 MBTU 3 = 2 MBTU 4 = 2.5 MBTU 5 = 3 MBTU	Default = 1 (1 MBTU)

TABLE 2-2: C-More Controller Standard Holding Register Address Mapping

Modbus Data Address	Menu Item	Units and Range	Comments
12 (0x000C)	Boiler Mode	enum (0, 1, 2, 3, 4): 0 = Constant Setpt 1 = Remote Setpt 2 = Direct Drive 3 = Combo Unit 4 = Outdoor Reset	Default = 0 (Constant Setpt)
13 (0x000D)	Remote Signal	enum (0, 1, 2, 3): 0 = 4 - 20 mA /1 - 5V 1 = 0 -20mA/0 - 5V 2 = PWM Input 3 = Network	Default = 0 (4 - 20 mA/1 - 5V)
14 (0x000E)	Bldg Ref Temp	DEGREES_1 (0 to 1000)	See Appendix A, Tables A-2 and A-3 for Conversions
15 (0x000F)	Reset Ratio	Int (1 to 99 counts) Actual Range = 0.1 to 9.9 (Counts = Actual x 10)	Actual Default = 1.2 Therefore: 1.2 x 10 = 12 counts
16 (0x0010)	Outdoor Sensor Enable	bool (0,1) 0 = False 1 = True	Default = 0 (False)
17 (0x0011)	System Start Temp	DEGREES_2 (0 to 1000)	See Appendix A, Tables A-2 and A-3 for Conversions Default = 60°F
18 (0x0012)	Set Point Lo Limit	DEGREES_1 (0 to 1000)	See Appendix A, Tables A-2 and A-3 for Conversions Default = 60°F
19 (0x0013)	Set Point Hi Limit	DEGREES_1 (0 to 1000)	See Appendix A, Tables A-2 and A-3 for Conversions Default = 200°F
20 (0x0014)	Temp Hi Limit	DEGREES_1 (0 to 1000)	See Appendix A, Tables A-2 and A-3 for Conversions Default = 210°F
21 (0x0015)	Max Fire Rate	% (40 - 100)	Default = 100%
22 (0x0016)	Pump Delay Timer	MIN_UNITS (0 to 30) 1count/min	Default = 0 min.
23 (0x0017)	Aux Start On Delay	SEC_UNITS (0 to 120) 1count/sec	Default = 0 sec.
24 (0x0018)	Failsafe Mode	enum (0, 1) 0=Shutdown 1=Constant Setpoint	Default = 0 (Shutdown)
25 (0x0019)	Low Fire Timer	SEC_UNITS (2 to 60) 1count/sec	Default = 2 sec.
26 (0x001A)	Prop Band	ABS_DEG_1 (0 to 1000)	See Appendix A, Tables A-2 and A-3 for Conversions

TABLE 2-2: C-More Controller Standard Holding Register Address Mapping

Modbus Data Address	Menu Item	Units and Range	Comments
27 (0x001B)	Integral Gain	0.00 to 2.00 (0.01 increments)	Actual x 100 Counts Defaults: Boiler: 0.10 (10 counts), Heater: 1.60 (160 counts)
28 (0x001C)	Derivative Time	MIN_UNITS (0.00 to 2.00) (0.01 min. increments) 1count/0.01min	Actual x 100 Counts Defaults: Boiler: 0.00 min. (0 counts) Heater: 0.10 min (10 counts)
29 (0x001D)	Min Load Adjust	ABS_DEG_1 (0 to 1000)	Water Heater ONLY See Appendix A, Tables A-2 and A-3 for Conversions
30 (0x001E)	Max Load Adjust	ABS_DEG_1 (0 to 1000)	Water Heater ONLY See Appendix A, Tables A-2 and A-3 for Conversions
31 (0x001F)	Outlet Feedback	bool (0, 1) 0 = Off 1 = On	Default = 1 (On) Water Heater ONLY
32 (0x0020) Thru 59 (0x003B)	(Reserved)		
60 (0x003C)	Set Point Limiting	bool (0, 1) 0 = Disabled 1 = Enabled	Default = 0 (Disabled)
61 (0x003D)	Set Point Limit Band	ABS_DEG_1 (0 to 1000)	See Appendix A, Tables A-2 and A-3 for Conversions
62 (0x003E) Thru 66 (0x0042)	(Reserved)		
67 (0x0043)	Sensor Log Interval	Enum (0 to 8) 0 = Off 1 = 1 Min. 2 = 5 Min. 3 = 15 Min. 4 = 30 Min. 5 = 1 Hr. 6 = 6 Hrs 7 = 12 Hrs. 8 = 24 Hrs.	Default = 4 (30 min)
68 (0x0044)	Fault Log Pointer	int 0 - 9	
69 (0x0045)	Sensor Log Pointer	int 0 - 1199	
70 (0x0046)	Time Log Pointer	int 0 - 10239	

TABLE 2-2: C-More Controller Standard Holding Register Address Mapping

Modbus Data Address	Menu Item	Units and Range	Comments
71 (0x0047) through 65535 (0xFFFF)	(Reserved)		Available for future expansion.

2.3 BMS/BMS II Controller Standard Register Assignments

2.3.1 BMS/BMS II Controller Standard Input Register Assignments

The following table lists the Read Only Input Register address assignments for the BMS/BMS II; Modbus Data Address in Decimal (Hex).

TABLE 2-3: BMS/BMS II Standard Input Register Address Mapping

Modbus Data Address	Menu Item	Units and Range	Default/ Comments
0 (0x0000)	(Reserved)		
1 (0x0001)	Header Temperature	40 to 220°F	
2 (0x0002)	Outside Air Temperature	-60 to 120°F	
3 (0x0003)	Indoor Air/Return Temperature	40 to 220°F	Indoor Air Temp = BMS Return Temp = BMS II
4 (0x0004)	Fire Rate Out	0 to 100% (out to boilers)	
5 (0x0005)	Header Set Temperature	40 to 220°F	
6 (0x0006)	Network Address	128 to 247	Default = 128 (If Address = 0, BMS/ BMS II is Off-Line as a Slave)
7 (0x0007)	Total Boilers Fired	0 to 40 (for BMS) 0 to 32 (for BMS II)	
8 (0x0008)	Total Boilers On Line	0 to 40 (for BMS) 0 to 32 (for BMS II)	
9 (0x0009)	(Reserved)		
10 (0x000A)	Fault/Message Code	0 to 65535. <u>Bit:</u> 0 = Outside Air Sensor 1 = Header Sensor Error 2 = Interlock 1 Error 3 = Interlock 2 Error 4 = Indoor Air Sensor Error/ Return Sensor Error 5 = 4-20mA Input Error	Interpret Bit 4 as follows: Indoor Air Sensor Error applies to BMS. Return Sensor Error applies to BMS II.

TABLE 2-3: BMS/BMS II Standard Input Register Address Mapping			
Modbus Data Address	Menu Item	Units and Range	Default/ Comments
11 thru 15 (0x000B) to (0x000F)	(Reserved)		
16 (0x0010)	Lead Boiler Number	1 to 40 (for BMS) 1 to 32 (for BMS II)	
17 (0x0011)	Boiler 1 Status (PWM Boiler 1)	119 = Not On-Line 120 = On-Line But Not Fired 1-40 = Fired & Sequence	Boilers 1 - 8 are referred to as the Legacy (PWM) Boilers.(BMS Only)
18 (0x0012)	Boiler 2 Status (PWM Boiler 2)	(Same As Above)	(Same As Above) (BMS Only)
19 (0x0013)	Boiler 3 Status (PWM Boiler 3)	(Same As Above)	(Same As Above) (BMS Only)
20 (0x0014)	Boiler 4 Status (PWM Boiler 4)	(Same As Above)	(Same As Above) (BMS Only)
21 (0x0015)	Boiler 5 Status (PWM Boiler 5)	(Same As Above)	(Same As Above) (BMS Only)
22 (0x0016)	Boiler 6 Status (PWM Boiler 6)	(Same As Above)	(Same As Above) (BMS Only)
23 (0x0017)	Boiler 7 Status (PWM Boiler 7)	(Same As Above)	(Same As Above) (BMS Only)
24 (0x0018)	Boiler 8 Status (PWM Boiler 8)	(Same As Above)	(Same As Above) (BMS Only)
25 (0x0019)	Boiler 9 Status (BMS) (Net Boiler 1) Boiler 1 Status (BMS II)	119 = Not On-Line 120 = On-Line But Not Fired 1-40 = Fired & Sequence 121 = On-Line But Disabled 122 = On-Line But Faulted	Boilers 9 - 32 are the Network Boilers. BMS II has only Network Boilers, therefore Net Boiler 1 = Boiler 1, etc.
26 (0x001A)	Boiler 10 Status (BMS) (Net Boiler 2) Boiler 2 Status (BMS II)	Same As Above	
27 (0x001B)	Boiler 11 Status (BMS) (Net Boiler 3) Boiler 3 Status (BMS II)	Same As Above	
28 (0x001C)	Boiler 12 Status (BMS) (Net Boiler 4) Boiler 4 Status (BMS II)	Same As Above	
29 (0x001D)	Boiler 13 Status (BMS) (Net Boiler 5) Boiler 5 Status (BMS II)	Same As Above	
30 (0x001E)	Boiler 14 Status (BMS) (Net Boiler 6) Boiler 6 Status (BMS II)	Same As Above	
31 (0x001F)	Boiler 15 Status (BMS) (Net Boiler 7) Boiler 7 Status (BMS II)	Same As Above	

TABLE 2-3: BMS/BMS II Standard Input Register Address Mapping

Modbus Data Address	Menu Item	Units and Range	Default/ Comments
32 (0x0020)	Boiler 16 Status (BMS) (Net Boiler 8) Boiler 8 Status (BMS II)	Same As Above	
33 (0x0021)	Boiler 17 Status (BMS) (Net Boiler 9) Boiler 9 Status (BMS II)	119 = Not On-Line 120 = On-Line But Not Fired 1-40 = Fired & Sequence 121 = On-Line But Disabled 122 = On-Line But Faulted	
34 (0x0022)	Boiler 18 Status (BMS) (Net Boiler 10) Boiler 10 Status (BMS II)	Same As Above	
35 (0x0023)	Boiler 19 Status (BMS) (Net Boiler 11) Boiler 11 Status (BMS II)	Same As Above	
36 (0x0024)	Boiler 20 Status (Net Boiler 12) Boiler 12 Status (BMS II)	Same As Above	
37 (0x0025)	Boiler 21 Status (Net Boiler 13) Boiler 13 Status (BMS II)	Same As Above	
38 (0x0026)	Boiler 22 Status (Net Boiler 14) Boiler 14 Status (BMS II)	Same As Above	
39 (0x0027)	Boiler 23 Status (Net Boiler 15) Boiler 15 Status (BMS II)	Same As Above	
40 (0x0028)	Boiler 24 Status (Net Boiler 16) Boiler 16 Status (BMS II)	Same As Above	
41 (0x0029)	Boiler 25 Status (Net Boiler 17) Boiler 17 Status (BMS II)	Same As Above	
42 (0x002A)	Boiler 26 Status Net Boiler 18) Boiler 18 Status (BMS II)	Same As Above	
43 (0x002B)	Boiler 27 Status (Net Boiler 19) Boiler 19 Status (BMS II)	Same As Above	
44 (0x002C)	Boiler 28 Status (Net Boiler 20) Boiler 20 Status (BMS II)	Same As Above	
45 (0x002D)	Boiler 29 Status (Net Boiler 21) Boiler 21 Status (BMS II)	Same As Above	
46 (0x002E)	Boiler 30 Status (Net Boiler 22) Boiler 22 Status (BMS II)	Same As Above	
47 (0x002F)	Boiler 31 Status (Net Boiler 23) Boiler 23 Status (BMS II)	119 = Not On-Line 120 = On-Line But Not Fired 1-40 = Fired & Sequence 121 = On-Line But Disabled 122 = On-Line But Faulted	

TABLE 2-3: BMS/BMS II Standard Input Register Address Mapping

Modbus Data Address	Menu Item	Units and Range	Default/ Comments
48 (0x0030)	Boiler 32 Status (Net Boiler 24) Boiler 24 Status (BMS II)	Same As Above	
49 (0x0031)	Boiler 33 Status (Net Boiler 25) Boiler 25 Status (BMS II)	Same As Above	
50 (0x0032)	Boiler 34 Status (Net Boiler 26) Boiler 26 Status (BMS II)	Same As Above	
51 (0x0033)	Boiler 35 Status (Net Boiler 27) Boiler 27 Status (BMS II)	Same As Above	
52 (0x0034)	Boiler 36 Status (Net Boiler 28) Boiler 28 Status (BMS II)	Same As Above	
53 (0x0035)	Boiler 37 Status (Net Boiler 29) Boiler 29 Status (BMS II)		
54 (0x0036)	Boiler 38 Status (Net Boiler 30) Boiler 30 Status (BMS II)	Same As Above	
55 (0x0037)	Boiler 39 Status (Net Boiler 31) Boiler 31 Status (BMS II)	Same As Above	
56 (0x0038)	Boiler 40 Status (Net Boiler 32) Boiler 32 Status (BMS II)	Same As Above	
57 (0x0039)	I/O Status	0 to 255	Bit map of Input/Output status (BMS II Only) Bit 0 = AUX Relay Bit 1 = Fault Relay Bit 2 = Sys Start Relay Bit 3 = Empty Bit 4 = Setback Bit 5 = Interlock 2 Bit 6 = Interlock 1 Bit 7 = Empty
58 (0x003A)	Return Sensor Temp	40 °F to 220°F	BMS II Only
59 (0x003B) to 90 (0x005A)	Net Blr 1 Outlet Temp to Net Blr 32 Outlet Temp	40°F to 220°F	When Blr Cntl Type = 1 or 2
92 (0x005C) to 123 (0x007B)	Net Blr 1 Code to Net Blr 32 Code	0 to 64 for C-More; 0 to 65535 for MLX (BCM)	
124 (0x007C) to 65535 (0xFFFF)	(Reserved for future expansion)		

2.3.2 BMS/BMS II Controller Standard Holding Register Assignments

The following table lists the Holding Register address assignments for the BMS/BMS II/ACS; Modbus Data Address in Decimal (Hex). Unless otherwise specified, all Holding Register Menu items are Read/Write (R/W).

TABLE 2-4: BMS/BMS II Standard Holding Register Address Mapping

Modbus Data Address	Menu Item	Units and Range	Default/ Comments
0 (0x0000)	(Reserved)		
1 (0x0001)	(Reserved)		
2 (0x0002)	(Reserved)		
3 (0x0003)	(Reserved)		
4 (0x0004)	Net Header Set Temp	40 to 220°F	Valid when Header Set Mode = Remote Setpt and Remote Signal = Network
5 (0x0005)	System Start Temp	32 to 120°F	Default = 70°F
6 (0x0006)	System Start Option	0 or 1, 0 = Temp Only, 1 = Temp and Load	Default = 0
7 (0x0007)	Manual Hdr Set Temp/Internal Setpt	40 to 220°F	Default = 160°F
8 (0x0008)	Bldg Ref Temp	40 to 220°F	Default = 70°F
9 (0x0009)	Indoor Prop Band	0.0 to 20.0°F/°F (0.5°F/°F increments)	Default = 00.0°F/°F (Value x 10) (BMS Only)
10 (0x000A)	Indoor Setpoint Temp	50 to 150°F	Default = 70°F (BMS Only)
11 (0x000B)	Reset Ratio	0.3 to 3.0 (0.1 increments),	Default = 1.2 (Value x 10)
12 (0x000C)	Max Header Temp	40 to 220°F	Default = 220°F
13 (0x000D)	Min Header Temp	40 to 220°F	Default = 40°F
14 (0x000E)	Start Percent	25 to 100%	Default = 45% (BMS) Default = 20% (BMS II)
15 (0x000F)	Stop Percent	10 to 45%	Default = 18% (BMS) Default = 16% (BMS II)
16 (0x0010)	Integral Gain	0.00 to 9.99 Rep/Min (in 0.01 increments)	Default = 0.15 Rep/Min (Value x 100)
17 (0x0011)	Header Set Mode	0, 1, or 2 0 = Constant Setpt 1 = In/Outdoor Reset 2 = Remote Setpt	Default = 0 (Constant Setpt)
18 (0x0012)	Derivative Gain	-2.00 to 2.00 (0.00 increments)	Default = 0.15 (Value x 100)

TABLE 2-4: BMS/BMS II Standard Holding Register Address Mapping

Modbus Data Address	Menu Item	Units and Range	Default/ Comments
19 (0x0013)	Header Temp Bandwidth	5 to 120°F	Default = 70°F
20 (0x0014)	Aux Relay Open	0 to 99%	Default = 45%
21 (0x0015)	Aux Relay Mode	0 or 1 0 = 100% Fire Rate 1 = 100% Fire Rate and Off	Default = 1 (100% Fire Rate & Off)
22 (0x0016)	Temp Sensor Fail Mode/Failsafe Mode	0 or 1 0 = Shutdown 1 = Switch Inputs/Constant Setpt	Default = 0 (Shutdown)
23 (0x0017)	Fault Alarm Relay Mode	0, 1, 2, 3 0 = All Faults, 1 = No Interlock 2 = Interlock 1 3 = Interlock 2	Default = 0 (All Faults)
24 (0x0018)	Fault Alarm Clear Method	0 or 1 0 = Automatic 1 = Manual	Default = 0 (Automatic)
25 (0x0019)	Boiler Operation Mode	0, 1 or 2 0 = Parallel 1 = Sequential 2 = Combination	Default = 1 (Sequential)
26 (0x001A)	Number Of Combination Mode Boilers	0 to 4	Default = 0 (BMS Only) (Start at Boiler 8 and work back to Boiler 5 to assign Combo Boilers)
27 (0x001B)	(Reserved)		
28 (0x001C)	(Reserved)		
29 (0x001D)	(Reserved)		
30 (0x001E)	Max Power Input	50 to 100%	Default = 100% (Fire Rate)
31 (0x001F)	Interlock 1 Method (BMS)/Sys Intlk Config (BMS II)	0 or 1 0 = Always Enabled 1 = Start Enabled	Default = 1 (Start Enabled)
32 (0x0020)	Real Time Clock Minutes	00 to 59 Minutes	Present Time
33 (0x0021)	Real Time Clock Hours	00 to 23 Hours	Present Time
34 (0x0022)	Real Time Clock Day of Week	1 to 7	Present Day
35 (0x0023)	Real Time Clock Year	00 to 99	Present Year

TABLE 2-4: BMS/BMS II Standard Holding Register Address Mapping

Modbus Data Address	Menu Item	Units and Range	Default/ Comments
36 (0x0024)	Real Time Clock Day of Month	01 to 31	Present Day of Month
37 (0x0025)	Real Time Clock Month	01 to 12	Present Month
38 (0x0026)	Offset Temp Day 1	-50 to 50°F	Default = 0°F
39 (0x0027)	Offset Temp Day 2	-50 to 50°F	Default = 0°F
40 (0x0028)	Offset Temp Day 3	-50 to 50°F	Default = 0°F
41 (0x0029)	Offset Temp Day 4	-50 to 50°F	Default = 0°F
42 (0x002A)	Offset Temp Day 5	-50 to 50°F	Default = 0°F
43 (0x002B)	Offset Temp Day 6	-50 to 50°F	Default = 0°F
44 (0x002C)	Offset Temp Day 7	-50 to 50°F	Default = 0°F
45 (0x002D)	Offset On Time Day 1 – Minutes	00 to 59 Minutes	Default = 0
46 (0x002E)	Offset On Time Day 2 – Minutes	00 to 59 Minutes	Default = 0
47 (0x002F)	Offset On Time Day 3 – Minutes	00 to 59 Minutes	Default = 0
48 (0x0030)	Offset On Time Day 4 – Minutes	00 to 59 Minutes	Default = 0
49 (0x0031)	Offset On Time Day 5 – Minutes	00 to 59 Minutes	Default = 0
50 (0x0032)	Offset On Time Day 6 – Minutes	00 to 59 Minutes	Default = 0
51 (0x0033)	Offset On Time Day 7 – Minutes	00 to 59 Minutes	Default = 0
52 (0x0034)	Offset On Time Day 1 – Hours	00 to 23 Hours	Default = 0
53 (0x0035)	Offset On Time Day 2 – Hours	00 to 23 Hours	Default = 0
54 (0x0036)	Offset On Time Day 3 – Hours	00 to 23 Hours	Default = 0
55 (0x0037)	Offset On Time Day 4 – Hours	00 to 23 Hours	Default = 0
56 (0x0038)	Offset On Time Day 5 – Hours	00 to 23 Hours	Default = 0
57 (0x0039)	Offset On Time Day 6 – Hours	00 to 23 Hours	Default = 0

TABLE 2-4: BMS/BMS II Standard Holding Register Address Mapping

Modbus Data Address	Menu Item	Units and Range	Default/ Comments
58 (0x003A)	Offset On Time Day 7 – Hours	00 to 23 Hours	Default = 0
59 (0x003B)	Offset Enable	0 or 1 0 = Disabled 1 = Enabled	Default = 0 (Disabled)
60 (0x003C)	Header Offset	0 to 5°F	Default = 0°F
61 (0x003D)	System Start Interlock	1, 2 or 3 1 = Either Intlk Opens Start Relay 2 = Intlk1 Opens Start Relay 3 = Intlk 2 Open Start Relay	Default = 2 (Intlk 1)
62 (0x003E) Thru 69 (0x0045)	(Reserved)		
70 (0x0046)	Offset Off Time Day 1 – Minutes	0 to 59 Minutes	Default = 0
71 (0x0047)	Offset Off Time Day 2 – Minutes	0 to 59 Minutes	Default = 0
72 (0x0048)	Offset Off Time Day 3– Minutes	0 to 59 Minutes	Default = 0
73 (0x0049)	Offset Off Time Day 4– Minutes	0 to 59 Minutes	Default = 0
74 (0x004A)	Offset Off Time Day 5 – Minutes	0 to 59 Minutes	Default = 0
75 (0x004B)	Offset Off Time Day 6 – Minutes	0 to 59 Minutes	Default = 0
76 (0x004C)	Offset Off Time Day 7 – Minutes	0 to 59 Minutes	Default = 0
77 (0x004D)	Offset Off Time Day 1 – Hours	0 to 23 Hours	Default = 0
78 (0x004E)	Offset Off Time Day 2 – Hours	0 to 23 Hours	Default = 0
79 (0x004F)	Offset Off Time Day 3 – Hours	0 to 23 Hours	Default = 0
80 (0x0050)	Offset Off Time Day 4 – Hours	0 to 23 Hours	Default = 0
81 (0x0051)	Offset Off Time Day 5 – Hours	0 to 23 Hours	Default = 0
82 (0x0052)	Offset Off Time Day 6 – Hours	0 to 23 Hours	Default = 0

TABLE 2-4: BMS/BMS II Standard Holding Register Address Mapping

Modbus Data Address	Menu Item	Units and Range	Default/ Comments
83 (0x0053)	Offset Off Time Day 7 – Hours	0 to 23 Hours	Default = 0
84 (0x0054)	(Reserved)		
85 (0x0055)	Indoor Air Input	0 or 1 0 = 4 – 20 Ma 1 = Thermistor	Default = 1 (Thermistor) BMS Only
86 (0x0056)	Remote Signal	0 or 1 0 = 4 – 20 Ma 1 = Network	Default = 0 (4 – 20 Ma)
87 (0x0057)	RS232 Mode	0 or 1 0 = Normal 1 = Modbus	Default = 0 (Normal)
88 (0x0058)	RS232 Baud Rate	2400, 4800, 9600, 14.4k, 19.2k	Default = 9600
89 (0x0059)	Number Of Network Boilers	0 to 32	Default = 0 (for BMS) Default = 2 (for BMS II)
90 (0x005A)	Min Slave Address	0 to 127	Default = 0
91 (0x005B)	Max Slave Address	0 to 127,	Default = 0
92 (0x005C)	Net Boiler 1 Address	Address for Network Boiler 1	Default = 0 (for BMS) Default = 1 (for BMS II)
93 (0x005D)	Net Boiler 2 Address	Address for Network Boiler 2	Default = 0 (for BMS) Default = 2 (for BMS II)
94 (0x005E) To 123 (0x007B)	Net Boiler 3 Address To Net Boiler 32 Address	Address for Network Boiler 3 To Address for Network Boiler 32	Default = 0
124 (0x007C)	Network Baud	0=2400, 1=4800, 2=9600, 3=14.4k, 4=19.2k	Default = 2 (9600)
125 (0x007D)	Network Timeout	5 to 240 sec	Default = 60 sec.
126 (0x007E)	Password Lo	0 to 255 (73)	Default = 0
127 (0x007F)	Password Hi	0 to 255 (79)	Default = 0
128 (0x0080)	Modbus Control Type	0 = Round-Robin 1 = Broadcast	Default = 0 (Round Robin)
129 (0x0081)	Modbus Pass-Thru	0 = Disabled 1 = Enabled	Default = 0 (Disabled)
130 (0x0082)	Header Dead Band	1 to 15°F	Default – 5°F (BMS II Only)
131 (0x0083)	Outside Temp Sensor Offset	-10°F to 10°F	
132 (0x0084)	Ramp Up %/MIN	0 to 300	Default = 20 (BMS II Only)

TABLE 2-4: BMS/BMS II Standard Holding Register Address Mapping

Modbus Data Address	Menu Item	Units and Range	Default/ Comments
133 (0x0085)	Ramp Down %/MIN	0 to 300	Default = 200 (BMS II Only)
134 (0x0086)	Fault Alarm Boilers	0 = No Blr Faults, 1 = All Blr Faults	Default = 0
135 (0x0087)	4 to 20 mA Current Offset	-1.00 to 1.00 mA	Default = 0 (BMS II Only)
136 (0x0088)	Return Sensor Offset	-10.0 to 10.0	Default = 0 (BMS II Only)
137 (0x0089)	Load Start Pct	1 to Blr Start Level	Default =1 (BMS II Only)
138 (0x008A)	Load Stop Pct	0 to Load Start -1	Default =0 (BMS II Only)
139 (0x008B) thru 65535 (0xFFFF)	(Reserved For Future Expansion)	Undefined	
0x00A1	Boiler control select	0 = None, 1 = C-More 2 = MLX (BCM)	Default = 0

2.4 ACS Controller (Only) Standard Register Assignments

IMPORTANT!

All Modbus addresses specified in the following tables are written generically in hexadecimal format. However, many Building Automation Systems utilize another form of addressing where:

40001 is added to the generic address for a Holding Register address.

and

30001 is added to the generic address for an Input Register address.

Be sure to check the addressing scheme being used by the BAS that is being interfaced to the ACS.

2.4.1 ACS Controller Standard Input Register Assignments

The following table lists Read Only Input Register assignments for the ACS; Modbus Data Address in Decimal (Hex).

Modbus Data Address	Menu Item	Units and Range	Default/ Comments
0 (0x0000)	(Reserved)		
1 (0x0001)	Header Temperature	40 to 220°F	
2 (0x0002)	Outside Air Temperature	-60 to 120°F	
3 (0x0003)	Indoor Air/Return Temperature	40 to 220°F	
4 (0x0004)	Fire Rate Out	0 to 100% (out to boilers)	
5 (0x0005)	Header Set Temperature	40 to 220°F	
6 (0x0006)	Network Address	128 to 247	Default = 128
7 (0x0007)	Total Boilers Fired	0 to 32 (for ACS)	
8 (0x0008)	Total Boilers On Line	0 to 32	
9 (0x0009)	(Reserved)		
10 (0x000A)	Fault/Message Code	0 to 65535 Bit: 0 = Outside Air Sensor 1 = Header Sensor Error 2 = Interlock 1 Error 3 = Interlock 2 Error 4 = Indoor Air Sensor Error/ Return Sensor Error 5 = 4-20mA Input Error	
11 (0x000B) to 15 (0x000F)	(Reserved)		
16 (0x0010)	Lead Boiler Number	1 to 32	

TABLE 2-5: ACS Standard Input Register Address Mapping

Modbus Data Address	Menu Item	Units and Range	Default/ Comments
17 (0x0011) To 24 (0x0018)	Not Applicable		Used for 8 ACS Legacy (PWM) Boilers Only
25 (0x0019) To 56 (0x0038)	Boiler 1 Status (Net Boiler 1) To Boiler 32 Status (Net Boiler 32)	119 = Not On-Line 120 = On-Line But Not Fired 1-40 = Fired & Sequence 121 = On-Line But Disabled 122 = On-Line But Faulted	ACS has only Network Boilers so Net Boiler 1 = Boiler 1, etc.
57 (0x0039)	I/O Status	00 to 255	Bit map of Input/Output Status: Bit 0 = AUX Relay Bit 1 = Fault Relay Bit 2 = Sys Start Relay Bit 3 = Empty Bit 4 = Setback Bit 5 = Interlock 2 Bit 6 = Interlock 1 Bit 7 = Empty
58 (0x003A)	Return Sensor Temp	40°F to 220°F	When Ret Sensor Mode = Normal
59 (0x003B) To 90 (0x005A)	Net Blr 1 Outlet Temp To Net Blr 32 Outlet Temp	40°F to 220°F	When Blr Cntl Type = 1 or 2
91 (0x005B)	PLANT DT STATUS	10°F to 100°F	When Return Sensor Mode = NORMAL
92 (0x005C) To 123 (0x007B)	Net Blr 1 Code To Net Blr 32 Code	0 to 64 for C-More; 0 to 65535 for MLX (BCM)	
124 (0x007C) To 65535 (0xFFFF)	(Reserved for future expansion)	(Not defined)	

2.4.2 ACS Controller Standard Holding Register Assignments

The following table lists the Holding Register address assignments for the ACS; Modbus Data Address in Decimal (Hex). Unless otherwise specified, all Holding Register Menu items are Read/Write (R/W).

TABLE 2-6: ACS Standard Holding Register Address Mapping			
Modbus Data Address	Menu Item	Units and Range	Default/ Comments
0 (0x0000) To 3 (0x0003)	(Reserved)		
4 (0x0004)	Net Header Set Temp	40 to 220°F	Valid when Hdr Set Mode=Remote Setpt and Remote Signal = Network
5 (0x0005)	System Start Temp	32 to 120°F	Default = 70°F
6 (0x0006)	System Start Option	0 = Temp Only, 1 = Temp and Load	Default = 0
7 (0x0007)	Manual Hdr Set Temp/Internal Setpt	40 to 220°F	Default = 160°F
8 (0x0008)	Bldg Ref Temp	40 to 220°F	Default = 70°F
9 (0x0009)	Not Applicable		
10 (0x000A)	Not Applicable		
11 (0x000B)	Reset Ratio	0.3 to 3.0 (0.1 increments)	Default = 1.2 (Value x 10)
12 (0x000C)	Max Header Temp	40 to 220°F	Default = 200°F
13 (0x000D)	Min Header Temp	40 to 220°F	Default = 40°F
14 (0x000E)	Start Percent	25 to 100%	Default = 20%
15 (0x000F)	Stop Percent	10 to 45%	Default = 16%
16 (0x0010)	Integral Gain	0.00 to 9.99 Rep/Min (in 0.01 increments)	Default = 0.15 Rep/Min (Value x 100)
17 (0x0011)	Header Set Mode	0 = Constant Setpt 1 = In/Outdoor Reset 2 = Remote Setpt	Default = 0 (Constant Setpt)
18 (0x0012)	Derivative Gain	-2.00 to 2.00 (0.00 increments)	Default = 0.15 (Value x 100)
19 (0x0013)	Header Temp Bandwidth	5 to 120°F	Default = 70°F
20 (0x0014)	Aux Relay Open	0 to 99%	Default = 45%
21 (0x0015)	Aux Relay Mode	0 = 100% Fire Rate 1 = 100% Fire Rate and Off	Default = 1 (100% Fire Rate & Off)
22 (0x0016)	Failsafe Mode	0 = Shutdown 1 = Constant Setpt	Default = 0 (Shutdown)

TABLE 2-6: ACS Standard Holding Register Address Mapping

Modbus Data Address	Menu Item	Units and Range	Default/ Comments
23 (0x0017)	Fault Alarm Relay Mode	0 = All Faults, 1 = No Interlock 2 = Interlock 1 3 = Interlock 2	Default = 0 (All Faults)
24 (0x0018)	Fault Alarm Clear Method	0 = Automatic 1 = Manual	Default = 0 (Automatic)
25 (0x0019)	Boiler Operation Mode	0 = Parallel 1 = Sequential 2 = Combination	Default = 1 (Sequential)
26 (0x001A)	Not Applicable		
27 (0x001B) To 29 (0x001D)	(Reserved)		
30 (0x001E)	Max Power Input	50 to 100%	Default = 100% (Fire Rate)
31 (0x001F)	Sys Intlk Config	0 = Always Enabled 1 = Start Enabled	Default = 1 (Start Enabled)
32 (0x0020)	Real Time Clock Minutes	00 to 59	Present Time
33 (0x0021)	Real Time Clock Hours	00 to 23 Hours	Present Time
34 (0x0022)	Real Time Clock Day of Week	1 to 7	Present Day
35 (0x0023)	Real Time Clock Year	00 to 99	Present Year
36 (0x0024)	Real Time Clock Day of Month	01 to 31	Present Day of Month
37 (0x0025)	Real Time Clock Month	01 to 12	Present Month
38 (0x0026)	Offset Temp Sun.	-50 to 50°F	Default = 0°F
39 (0x0027)	Offset Temp Mon.	-50 to 50°F	Default = 0°F
40 (0x0028)	Offset Temp Tue.	-50 to 50°F	Default = 0°F
41 (0x0029)	Offset Temp Wed.	-50 to 50°F	Default = 0°F
42 (0x002A)	Offset Temp Thu.	-50 to 50°F	Default = 0°F
43 (0x002B)	Offset Temp Fri.	-50 to 50°F	Default = 0°F
44 (0x002C)	Offset Temp Sat.	-50 to 50°F	Default = 0°F
45 (0x002D)	Offset On Time Day 1 – Minutes	00 to 59 Minutes	Default = 0
46 (0x002E)	Offset On Time Day 2 – Minutes	00 to 59 Minutes	Default = 0
47 (0x002F)	Offset On Time Day 3 – Minutes	00 to 59 Minutes	Default = 0
48 (0x0030)	Offset On Time Day 4 – Minutes	00 to 59 Minutes	Default = 0

TABLE 2-6: ACS Standard Holding Register Address Mapping

Modbus Data Address	Menu Item	Units and Range	Default/ Comments
49 (0x0031)	Offset On Time Day 5 – Minutes	00 to 59 Minutes	Default = 0
50 (0x0032)	Offset On Time Day 6 – Minutes	00 to 59 Minutes	Default = 0
51 (0x0033)	Offset On Time Day 7 – Minutes	00 to 59 Minutes	Default = 0
52 (0x0034)	Offset On Time Day 1 – Hours	00 to 23 Hours	Default = 0
53 (0x0035)	Offset On Time Day 2 – Hours	00 to 23 Hours	Default = 0
54 (0x0036)	Offset On Time Day 3 – Hours	00 to 23 Hours	Default = 0
55 (0x0037)	Offset On Time Day 4 – Hours	00 to 23 Hours	Default = 0
56 (0x0038)	Offset On Time Day 5 – Hours	00 to 23 Hours	Default = 0
57 (0x0039)	Offset On Time Day 6 – Hours	00 to 23 Hours	Default = 0
58 (0x003A)	Offset On Time Day 7 – Hours	00 to 23 Hours	Default = 0
59 (0x003B)	Offset Enable	0 = Disabled 1 = Enabled	Default = 0 (Disabled)
60 (0x003C)	Header Temp Offset	-10 to 10°F	Default = 0°F
61 (0x003D)	System Start Interlock	1 = Intlk1 Opens Start Relay 2 = Intlk2 Opens Start Relay 3 = Either Intlk Opens Start Relay	Default = 1 (Intlk 1)
62 (0x003E) To 69 (0x0045)	(Reserved)		
70 (0x0046)	Offset Off Time Sun. – Minutes	0 to 59 Minutes	Default = 0
71 (0x0047)	Offset Off Time Mon. – Minutes	0 to 59 Minutes	Default = 0
72 (0x0048)	Offset Off Time Tue.– Minutes	0 to 59 Minutes	Default = 0
73 (0x0049)	Offset Off Time Wed.– Minutes	0 to 59 Minutes	Default = 0
74 (0x004A)	Offset Off Time Thu – Minutes	0 to 59 Minutes	Default = 0
75 (0x004B)	Offset Off Time Fri. – Minutes	0 to 59 Minutes	Default = 0
76 (0x004C)	Offset Off Time Sat. – Minutes	0 to 59 Minutes	Default = 0
77 (0x004D)	Offset Off Time Sun. – Hours	0 to 23 Hours	Default = 0
78 (0x004E)	Offset Off Time Mon. – Hours	0 to 23 Hours	Default = 0
79 (0x004F)	Offset Off Time Tue. – Hours	0 to 23 Hours	Default = 0
80 (0x0050)	Offset Off Time Wed. – Hours	0 to 23 Hours	Default = 0
81 (0x0051)	Offset Off Time Thu. – Hours	0 to 23 Hours	Default = 0
82 (0x0052)	Offset Off Time Fri. – Hours	0 to 23 Hours	Default = 0
83 (0x0053)	Offset Off Time Sat. – Hours	0 to 23 Hours	Default = 0

TABLE 2-6: ACS Standard Holding Register Address Mapping

Modbus Data Address	Menu Item	Units and Range	Default/ Comments
84 (0x0054)	(Reserved)		
85 (0x0055)	Not Applicable		
86 (0x0056)	Remote Signal	0 = 4 – 20 Ma 1 = Network	Default = 0 (4 – 20 Ma)
87 (0x0057)	RS232 Mode	0 = Normal 1 = Modbus	Default = 1 (Modbus)
88 (0x0058)	RS232 Baud Rate	0=2400, 1=4800, 2=9600, 3=14400, 4=19200	2 = 9600
89 (0x0059)	Number Of Network Boilers	0 to 32	Default = 2
90 (0x005A)	Min Slave Address	0 to 127	Default = 0
91 (0x005B)	Max Slave Address	0 to 127	Default = 0
92 (0x005C)	Net Boiler 1 Address	Address for Network Boiler 1	Default = 1
93 (0x005D)	Net Boiler 2 Address	Address for Network Boiler 2	Default = 2
94 (0x005E) To 123 (0x007B)	Net Boiler 3 Address To Net Boiler 32 Address	Address for Network Boiler 3 To Address for Network Boiler 32	Default = 0
124 (0x007C)	Network Baud	0=2400, 1=4800, 2=9600, 3=14400, 4=19200	2 = 9600
125 (0x007D)	Network Timeout	5 to 240 sec	Default = 60 sec.
126 (0x007E)	Password Lo	0 to 255 (73)	Default = 0
127 (0x007F)	Password Hi	0 to 255 (79)	Default = 0
128 (0x0080)	Modbus Control Type	0 = Round-Robin 1 = Broadcast	Default = 0 (Round Robin)
129 (0x0081)	Modbus Pass-Thru	0 = Disabled 1 = Enabled	Default = 0 (Disabled)
130 (0x0082)	Header Dead Band	1 to 15°F	Default = 5°F
131 (0x0083)	Outside Temp Sensor Offset	-50 to +50°F	Default = 0
132 (0x0084)	Dyn Up	0 to 300%/Min	Default = 20
133 (0x0085)	Dyn Down	0 to 300%/Min	Default = 200
134 (0x0086)	Fault Alarm Boilers	0 = No Blr Faults 1 = All Blr Faults	Default = 0
135 (0x0087)	4 to 20 mA Current Offset	-1.00 mA to 1.00 mA	Default = 0
136 (0x0088)	Return Sensor Offset	-10.0°F to 10.0°F	Default = 0
137 (0x0089)	Load Start Pct	1 to Blr Start Level	Default = 1

TABLE 2-6: ACS Standard Holding Register Address Mapping

Modbus Data Address	Menu Item	Units and Range	Default/ Comments
138 (0x008A)	Load Stop Pct	0 to Load Start Pct - 1	Default = 0
139 (0x008B)	Pass Through Write Enable	0 = Disabled 1 = Enabled	Default = 0
140 (0x008C)	Lead Boiler Select	0 (None) or 1	Default = 0
141 (0x008D)	Last Boiler Select	0 (None) or 1 - 32	Default = 0
142 (0x008E)	Rotate Time	0 to 999 hrs	?Default = 168 hrs
143 (0x008F)	Number Of DHW Boilers	0 to 8	Default = 0
144 (0x0090)	DHW Option	0 = No Option 1 = Option 1 (1 Valve) 2 = Option 2 (2 Valve) 3 = Option 3 (Boost)	Default = 0
145 (0x0091)	System Relay Option	0 = Normal 1 = DHW Valve 1 Close	Default = 0
146 (0x0092)	Number DHW Priority	0 to Num DHW Boilers - 1	Default = 1
147 (0x0093)	DHW Signal	0 = No Signal 1 = Special Signal	Default = 0
168 (0x0094)	return sensor mode	0 = Off 1 = Normal (Return Sensor) 2 = DHW/Tank Temp	Default = 0
149 (0x0095)	High DB Setpt Enable Level	Blr Stop Level to 100%	Default = Blr Stop Level
150 (0x0096)	Deadband High	0 to 25°	Default = 1
151 (0x0097)	Deadband Low	0 to 25°	Default = 1
152 (0x0098)	Setpoint Down Rate	0 to 100°/Min	Default = 100
153 (0x0099)	Demand Offset	0 to 100°	Default = 0
154 (0x009A)	Plant DT Limit	10 to 100°	Default = 40
155 (0x009B)	Boiler Delay Time	10 to 999 Sec	Default = 30
156 (0x009C)	Valve Wait State	0 = Off 1 = Current State	? Default = 0
157 (0x009D)	Boost Temp	Hdr Low Limit to Hdr High Limit	Default = 140
158 (0x009E)	Valve Wait Time	0 to 500 Sec	Default = 120
159 (0x009F)	Return Temp Boost Disable	Off, -80° to +80°	Default = Off
160 (0x00A0)	Modbus On.Off	0 = Front Panel Off 1 = On 2 = Modbus Off	Default = 0

TABLE 2-6: ACS Standard Holding Register Address Mapping

Modbus Data Address	Menu Item	Units and Range	Default/ Comments
161 (0x00A1)	Boiler Control Select	0 = None 1 = C-More 2 = MLX (BCM)	Default = 0
162 (0x00A2)	Boost Max Timer	0 (Off), 1 to 999 Min	Default = 0
163 (0x00A3) To 65535 (0xffff)	(Reserved For Future Expansion)		

(This page intentionally blank)

CHAPTER 3. STANDARD APPLICATION OPERATIONS

3.1 Introduction

This Section describes the standard application operations for AERCO C-More Boiler Controllers and the AERCO Boiler Management System (BMS/BMS II), and the AERCO Control System (ASC) and how they are achieved utilizing Modbus. Paragraphs 3.2 through 3.2.7 provide information for the C-More Boiler Controllers which can only function as Slaves in a Modbus Network. Paragraphs 3.3 through 3.3.4 provide similar information for the BMS, BMS II, and ACS, which can function as either a Master or Slave in a Modbus Network.

NOTE:

Additional information on Modbus hardware and software set up and installation are provided in Section 4 and Section 5 of this manual.

3.2 C-More Controller Standard Application Operations

The information in the following paragraphs apply to C-More Boiler Controllers with the following exceptions:

- C-More Boiler Controllers utilize a Fixed 10 second “Heartbeat” timer.
- C-More Boiler Controllers, require temperature readings to be converted from “counts” to °F or °C.

3.2.1 Password Protection for Input and Holding Register Access

Access to the C-More Input Register and Holding Register addresses are protected via security level passwords. Two separate Holding Register addresses (0x0002, 0x0003) are assigned for password entries, one for the Modbus (RS485) Network and one for the RS232 front panel user interface. If desired, separate security passwords can be entered for each interface.

Each C-More Controller menu parameter is assigned a preset security level that controls access from the front panel user interface. If the current communication password of the front-end software does not match the C-More Slave addresses security level, access is denied. When this occurs, an Illegal Data Address Exception Code (02) is generated and the data is not changed. If a Modbus message is received to read multiple Input or Holding Registers (Function Codes 03 or 04) and one or more of the register addresses is not accessible, an Illegal Data Address Exception Code will also be generated and no data is supplied to the Master. It should be noted that Modbus “Write Multiple Registers” command (Function Code 16) is not supported by AERCO C-More Controller Slaves and will cause an Illegal Function Exception Code to be generated.

The Holding Register data can be viewed without a password. However, the data cannot be changed without entering the appropriate password. The communications port security operation will mirror the security operation for viewing and adjusting parameters via the front panel keypad. Refer to C-More Operation Manual GF-112 for additional information on security passwords and menu access.

Simultaneous RS232 & RS485 Access to C-More Controller Variables

As previously mentioned, read and write access of the C-More Controller variables are protected from unauthorized access by an internal security level hierarchy. Passwords may be entered in the Slave's Holding Registers using any of the following methods:

- Locally via the front panel keypad and display
- Remotely via the front panel RS232 port
- Remotely via the Modbus (RS485) interface

It is imperative that the user understands that the LAST change made to any menu variable (including passwords) will supersede any previous change, regardless of which of the above methods is used. There is no priority structure assigned to any of the above methods and since they are not interlocked, they may be performed concurrently.

3.2.2 Direct Drive Control

In the Direct Drive Mode, the holding register parameter "Net Direct Drive" (address 0x0001) must be written or broadcast periodically from the BMS/BMS II/ACS (or EMS Master) to all Slave Controllers on the network. The Modbus message will specify the Fire Rate (0 to 100%) for the addressed Slave(s). If the Net Direct Drive message is broadcast, all enabled network Slaves will be set to the same fire rate percentage. However, if different fire rates are required for specific Slaves, each Slave must be addressed individually. Each time a network Slave successfully receives the Net Direct Drive message, it will reset its Heartbeat Timer which has a fixed 10 second timeout. If this timeout period is exceeded, the C-More Controller Slave will default to "Fail-Safe Mode" (Shutdown or Constant Setpoint) stored in holding register address 0x0018. When this occurs, "Modbus Comm Fault" will be displayed.

During operation in the Direct Drive Mode, only the Net Direct Drive variable in the Slave's Holding Register can be remotely adjusted. If desired, manual control via the C-More Controller front panel can be invoked by pressing the AUTO/MAN switch on the front panel.

3.2.3 Remote Setpoint Control

In the Remote Setpoint Mode, the holding register parameter "Net Remote Setpoint" (address 0x0000) must be written or broadcast periodically from the BMS/BMS II (or EMS Master) to all Slave Controllers on the network. The Modbus message will specify the Setpoint Temperature for the addressed Slave(s). If the Net Remote Setpoint message is broadcast, all enabled network Slaves will be set to the same setpoint temperature. However, if different setpoint temperatures are required for specific Slaves, each Slave must be addressed individually. Each time a network Slave successfully receives the Net Remote Setpoint message, it will reset its "Heartbeat". For C-More Controllers, the "Heartbeat" timeout is fixed at 10 seconds. If this timeout period is exceeded, the C-More Controller Slave will default to "Fail-Safe Mode" and display a "Modbus Comm Fault".

During operation in the Remote Setpoint Mode, only the "Net Remote Setpt" variable in the Slave's Holding Register can be remotely adjusted. If desired, manual control via the C-More Controller front panel can be invoked by pressing the AUTO/MAN switch on the front panel.

3.2.4 Combination Control (BMS/ACS Only)

The Combination Control Mode is only used for the BMS and ACS, **NOT** the BMS II. For BMS applications, Combination Control is implemented via PWM input. For ACS applications Combination Control is implanted via Modbus Network.

3.2.5 Physical Slave Address Zero

Normally, each Modbus Network Slave Controller will be assigned its own unique Comm. Address (Input Register Address 0x0013). Valid entries are from 1 to 127. However, if the default address of 0 is assigned, the C-More Slave, will not respond or process any Modbus Network messages. This effectively disables the Slave's Modbus communication link.

3.3 BMS/BMS II/ACS Standard Application Operations

For an AERCO BMS (only) Controller, the first eight Boilers are reserved for Legacy Boilers. These Legacy Boilers are wired to the J2 connector terminals and are controlled utilizing Pulse Width Modulation (PWM) signals, just as with earlier BMS Models, prior to implementation of Modbus. Therefore, Boiler No. 9 will be the first Modbus Network Boiler, Boiler No. 10 will be the second and so on. Up to 32 Network Boilers can be connected on a Modbus Network, in addition to the 8 Legacy Boilers. The BMS will operate the Network Boilers and the Legacy Boilers as one complete System.

The BMS II and ACS do not utilize PWM signals and will not operate a Legacy Boiler Controller that does not have Modbus capability. The BMS II and ACS will operate up to 32 Network Boilers.

3.3.1 Password Protection for BMS/BMS II/ACS Input and Holding Register Access

Access to BMS/BMS II/ACS register addresses are protected by a password in virtually the same manner as the C-More Controllers. For the BMS/BMS II/ACS, a communications security code holding register "Password Lo" and "Password Hi" (addresses 0x007E, 0x007F) must be written with the proper password for writing data in the BMS/BMS II/ACS through the RS232 communications port. If an attempt is made to write data to a single holding register using an incorrect password, write access is denied. If this occurs, an Illegal Data Address Exception Code (02) is generated and the data is not changed. Reading data is allowed, even if the password is incorrect. If a Modbus message is received to read multiple Input or Holding Registers and one or more of the addresses is not accessible, an Illegal Data Address Exception Code will be sent to the EMS Master and no data is affected.

Only the network control variable "Net Header Set Temp" (address 0x0004) can be written without a password and only if the BMS/BMS II/ACS is programmed for Remote Setpoint Control by an EMS Master.

3.3.2 Remote Setpoint Control of BMS/BMS II/ACS Slave By EMS Master

All Modbus communication between a BMS/BMS II/ACS Slave and an EMS Master is accomplished via the RS232 port. If the EMS Master also contains a RS232 port, it can be directly connected to the BMS/BMS II/ACS. However, if the EMS Master contains only a RS485 port, a RS232-to-RS485 Converter is required.

To enable the Remote Setpoint Mode, the parameters "Remote Signal" and "RS232 Mode" must be set to "Network" and "Modbus" respectively. These parameter are stored in Standard Holding Register addresses 0x0056 and 0x0057 respectively. Also, ensure that the RS232 Baud Rate setting (address 0x0058) matches the EMS Baud Rate being used.

In the Remote Setpoint Mode, the holding register parameter "Net Header Set Temp" (Holding

CHAPTER 3: Standard Application Operations

Register address 0x0004) must be transmitted periodically from the EMS Master to the BMS/ BMS II/ACS Slave. A “Heartbeat” Timer with a timeout period defined by the variable “Network Timeout” (Holding Register address 0x007D), is reset each time the signal is successfully received. If the timeout period is exceeded, the BMS/BMS II/ACS will default to its “Fail-Safe” mode and display a Network Comm Fault.

3.3.3 BMS/BMS II/ACS Master Control of C-More Slaves Via Network

The BMS/BMS II/ACS can also communicate with the up to 32 Network C-MORE Boiler Control Slaves via the BMS RS485 port. Parallel and Sequential control can be selected as before. See BMS Manual GF-108M, BMS II Manual GF-124, or ACS Manual GF-131 for additional information.

The “Number Of Network Boilers” must be entered at location 0x0059 in the Standard Holding Registers. The C-More Slave communication addresses (“Net Boiler 1 Address” To “Net Boiler 32 Address”) can either be manually entered in a pre-defined order in the BMS, or they can be detected from the network and operated in the order they are detected. To manually enter Network Boiler communication addresses, leave the “Min Slave Address” and “Max Slave Address” set to their default values of 0. To allow the BMS to automatically detect the Network Boilers, enter the respective “Min Slave Address” and “Max Slave Address” in their proper location in the Standard Holding Registers (0x005A, 0x005B). The Max Slave Address must be no more than 31 above the Min Slave Address.

The fire rate information will be transmitted periodically from the BMS/BMS II/ACS to the C-MORE boiler controls. A “heartbeat” timer will be reset in the slave each time the control information is successfully received from the BMS. If a timeout occurs, the slave will default to its “Fail-Safe Mode” and display “Modbus Comm Fault”.

3.3.4 BMS Combination Mode Boiler Control of C-More Slaves (BMS and ACS Only)

For BMS applications, the Legacy (PWM) Boilers 5 through 8 can be selected as Combination Boilers. These Boilers are connected to the BLR 5 - BLR 8 PWM terminal connections (J2). An AERCO Combination Control Panel (CCP) is necessary to configure this type of setup. It should be noted that the assigned PWM Combination Boilers can be monitored and configured on the Modbus Network by assigning a Comm Address between 1 and 127. Refer to BMS Manual GF-108M for additional information on installation and setup.

NOTE:

The C-More Demand Delay function can only be used on C-More Controllers with software version 2.01 or higher.

For ACS applications, the domestic boilers (up to 8 of 32 network boilers) can be selected as Combination Boilers. These boilers are connected to the RS485 terminal, JP6. Depending on the application, ACS Relay Panel may be required. See Application Guide TAG-0049 and ACS Manual GF-131.

CHAPTER 4. MODBUS NETWORK HARDWARE SETUP & INSTALLATION

4.1 Introduction

This Section provides basic information on planning and setup of a Modbus Communication Network utilizing AERCO C-More Boiler Controllers and Boiler Management Systems (BMS/ BMS II) and AERCO Control System (ACS). It also provides basic information on Modbus Network setup utilizing AERCO BMS/ BMS II/ACS or C-More Slaves with a Master EMS (or BAS) provided by other manufacturers.

4.2 Physical Modbus RS485 Network Wiring Connections

To properly perform combustion calibration, the proper instruments and tools must be used and correctly attached to the unit. The following paragraphs outline the necessary tools and instrumentation as well as their installation.

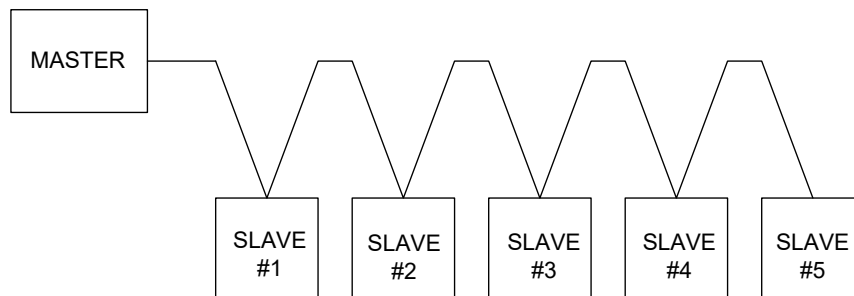

Figure 4-1: Typical Daisy-Chain Modbus/RS485 Network

The physical wiring connections for a Modbus Network utilizing an AERCO BMS/BMS II/ACS and C-More Boiler Controllers should be made using shielded twisted-pair wire, from 18 to 24 AWG. Examples of suitable wire are: Belden #9841, #8761, #3105A, or equivalent.

The actual locations of the wiring connectors necessary for Modbus Network implementation utilizing the AERCO BMS, BMS II, or ACS and C-More Boiler Controllers are provided in paragraphs 4.2.1 and 4.2.2 respectively. Where necessary, connector pin-out information is also provided.

4.2.1 BMS Slave To EMS Master Wiring Connections

Wiring connections between an EMS Master and an AERCO BMS Slave can be made at either the RS232 (DB9) port on the left side of the BMS, or at the internal RS232 connector located on the terminal board behind the connection cover on the BMS. These connections are shown in Figure 4-2. The internal RS232 connections are used when interfacing with an EMS Master via a conduit connection at the bottom edge of the BMS enclosure. If the internal RS232 connections are used, it is recommended that nothing be connected to the external RS232 (DB9) port.

If the EMS Master being used contains only an RS485 port (2-wire or 4-wire), an RS485-to-RS232 Converter is required. A BMS option is available with a built-in RS485-to-RS232 Converter to permit a conduit connection between the EMS and BMS. If the external RS232 port on the left side of the BMS is used, a separate external converter is required.

Simplified block diagrams showing the internal and external connection options between the BMS and EMS are shown in Figure 4-3. Connector pinouts for the external RS232 (DB9-Female) and internal

CHAPTER 4: Modbus Network Hardware Setup & Installation

RS232 connector are shown in Figure 4-4. In addition, Figure 4-4 shows the pin assignments for the internal RS485 connector mounted on the BMS terminal board. This connector is used to interface the boilers to the Modbus network.

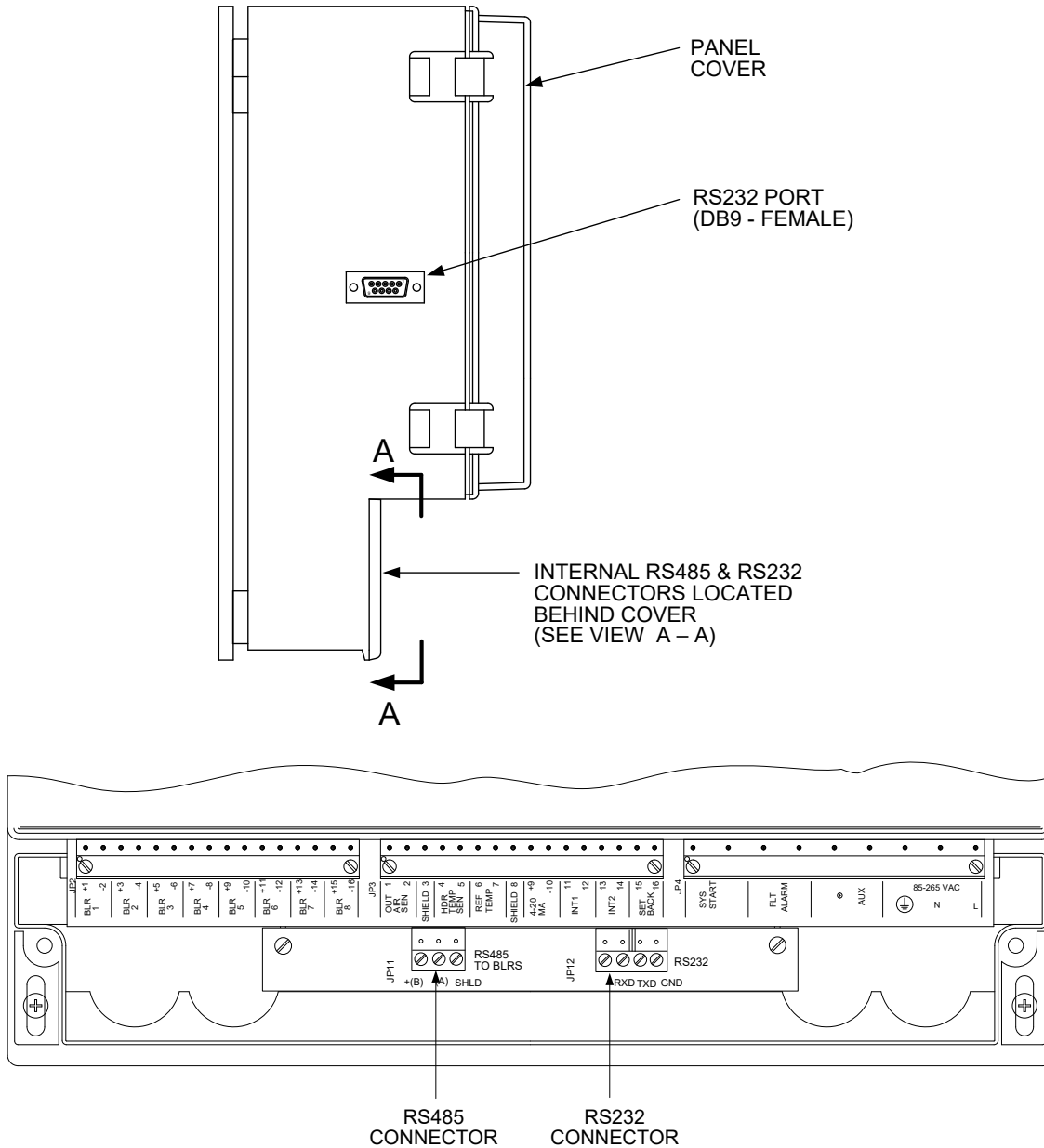

VIEW A – A
 (PARTIAL FRONT VIEW WITH COVER REMOVED)

Figure 4-2: BMS Left Side View

CHAPTER 4: Modbus Network Hardware Setup & Installation

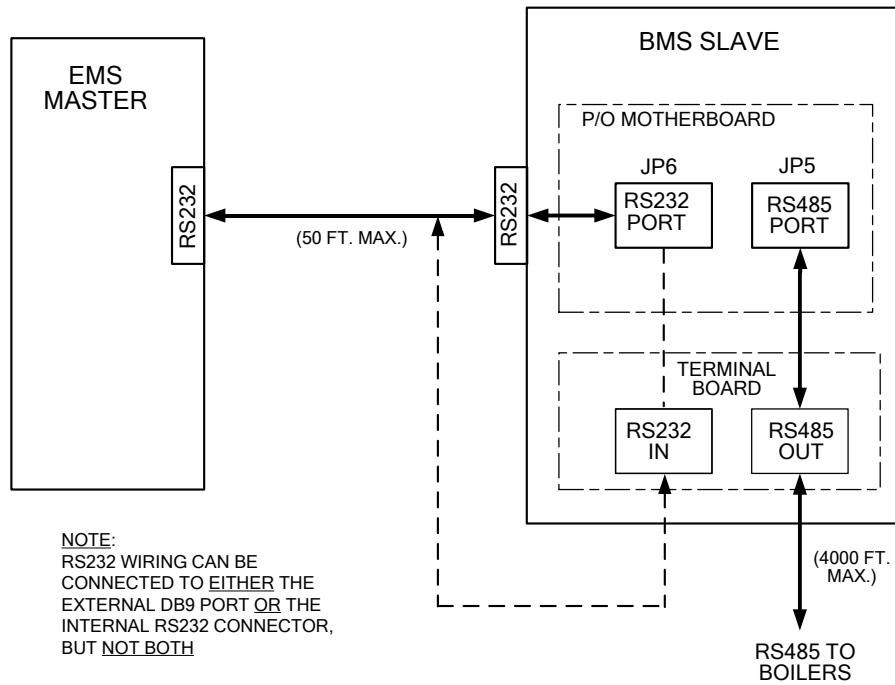

EMS RS232 PORT TO BMS RS232 PORT

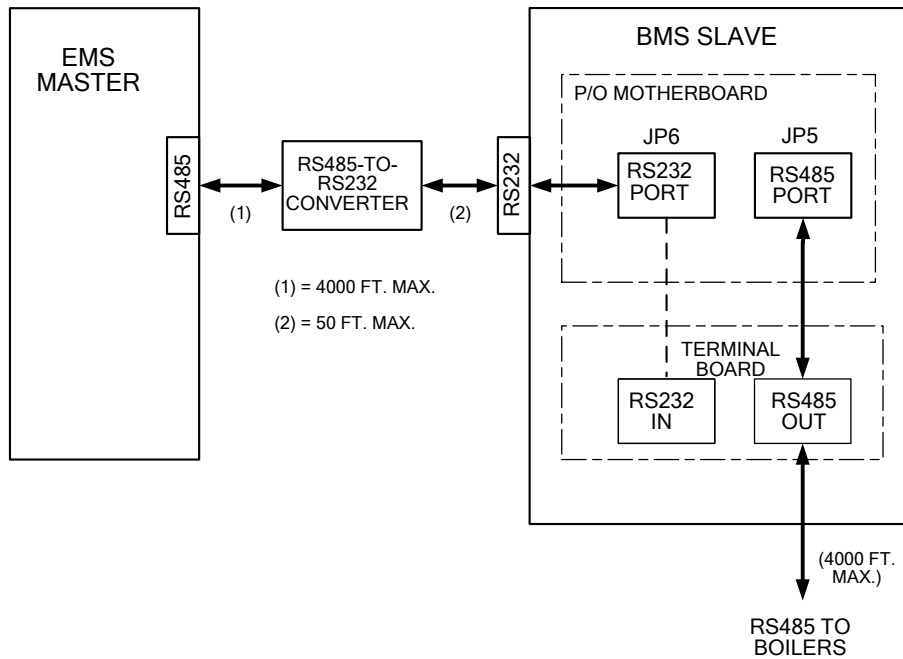

EMS RS485 PORT TO BMS RS232 PORT USING EXTERNAL CONVERTER

Figure 4-3: EMS Master-To-BMS Slave Connection Diagrams (Sheet 1 of 2)

CHAPTER 4: Modbus Network Hardware Setup & Installation

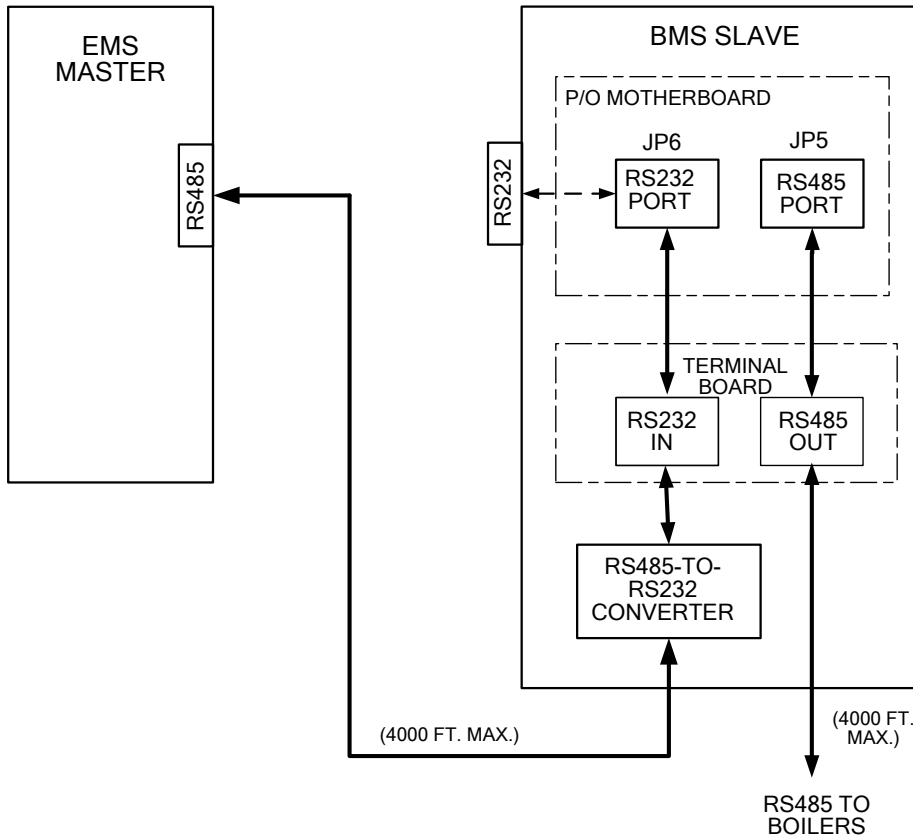

EMS RS485 PORT TO BMS RS232 PORT USING INTERNAL CONVERTER

Figure 4-3: EMS Master-To-BMS Slave Connection Diagrams (Sheet 2 of 2)

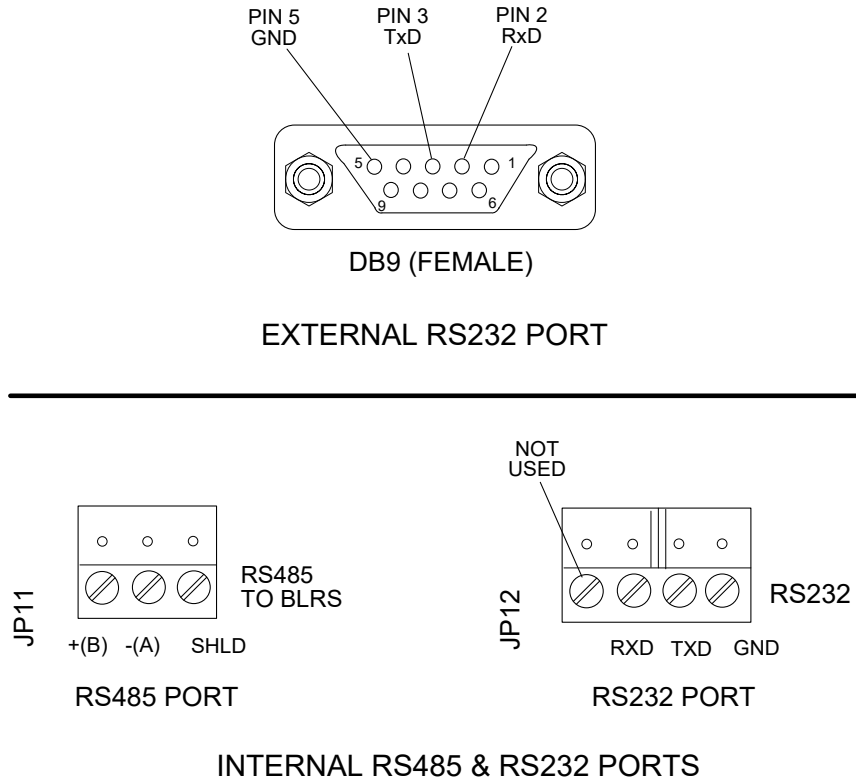

Figure 4-4: BMS RS232 & RS485 Connectors

4.2.2 BMS II/ACS Slave To EMS Master Wiring Connections

Wiring connections between an EMS Master and an AERCO BMS II/ACS Slave are made at the internal RS232 port terminals behind the wiring compartment cover of the BMS II/ACS. These connections are shown in Figure 4-5. These terminals are labeled RXD, TXD and 232 ISO GND. In addition, Figure 4-5 shows the internal RS485 terminals used to interface the boilers to the Modbus Network.

If the EMS Master being used contains only an RS485 port (2-wire or 4-wire), an RS485-to-RS232 Converter is required. A BMS II/ACS option is available with a built-in RS485-to-RS232 Converter to simplify connection between the EMS and BMS II/ACS. A separate external converter can also be used if desired.

Simplified block diagrams showing the internal and external connection options between the BMS II/ACS and EMS are shown in Figure 4-6.

CHAPTER 4: Modbus Network Hardware Setup & Installation

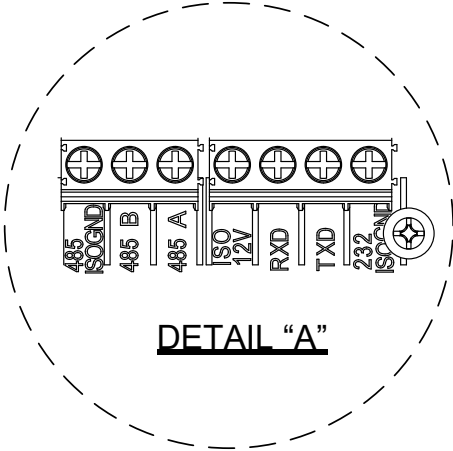
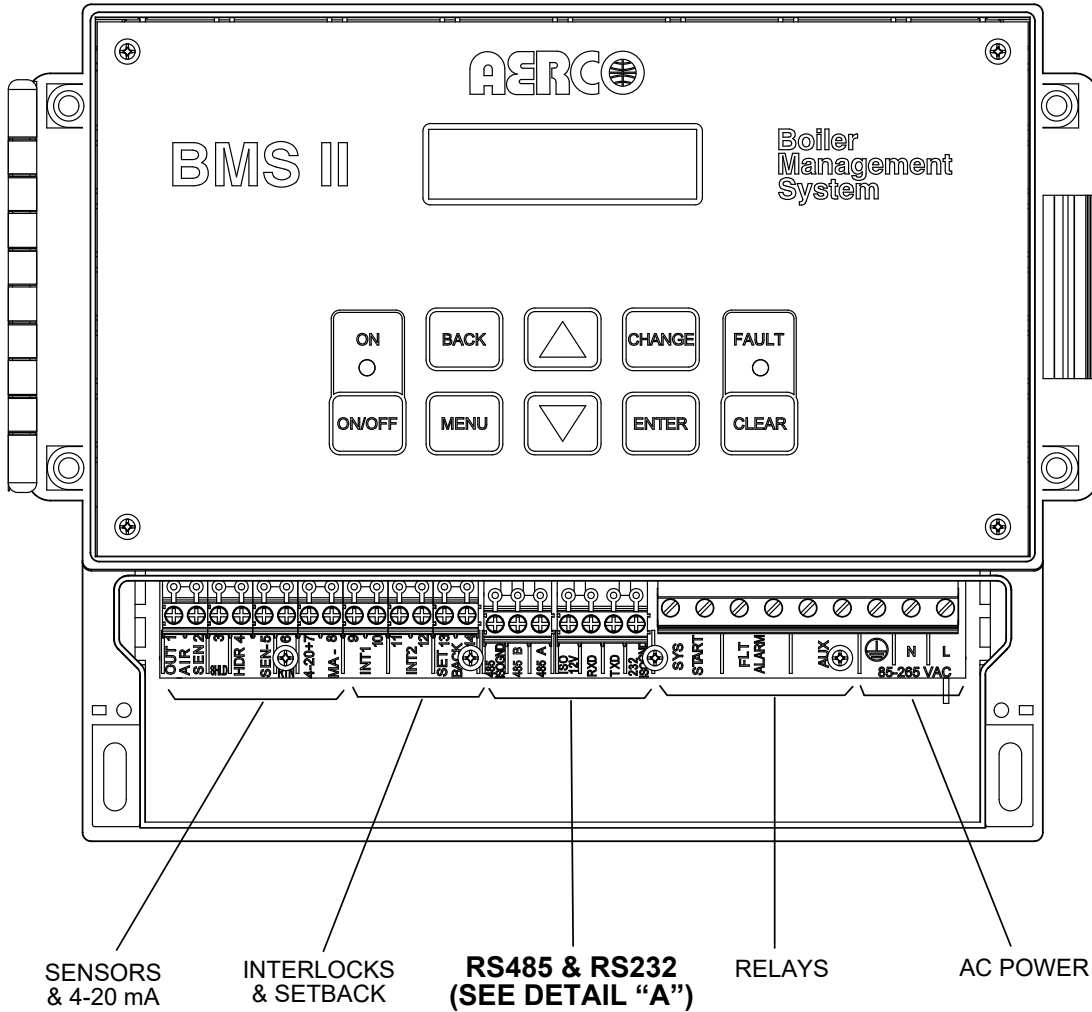
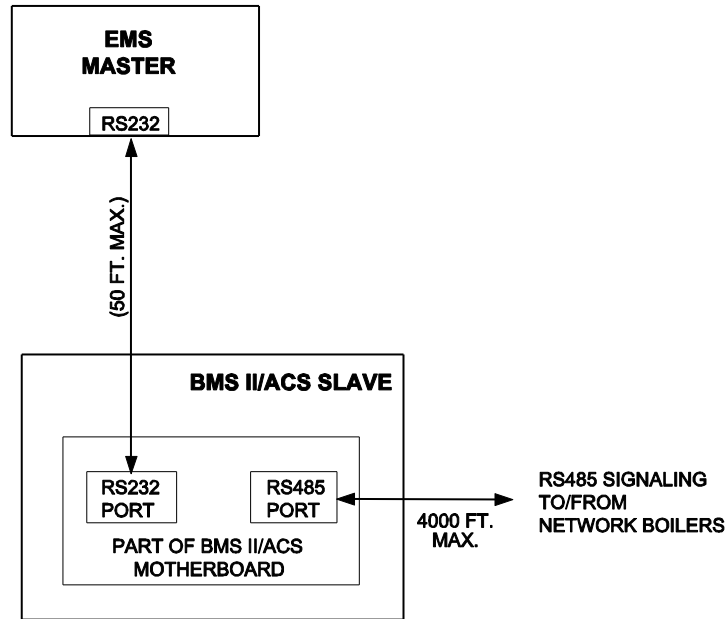
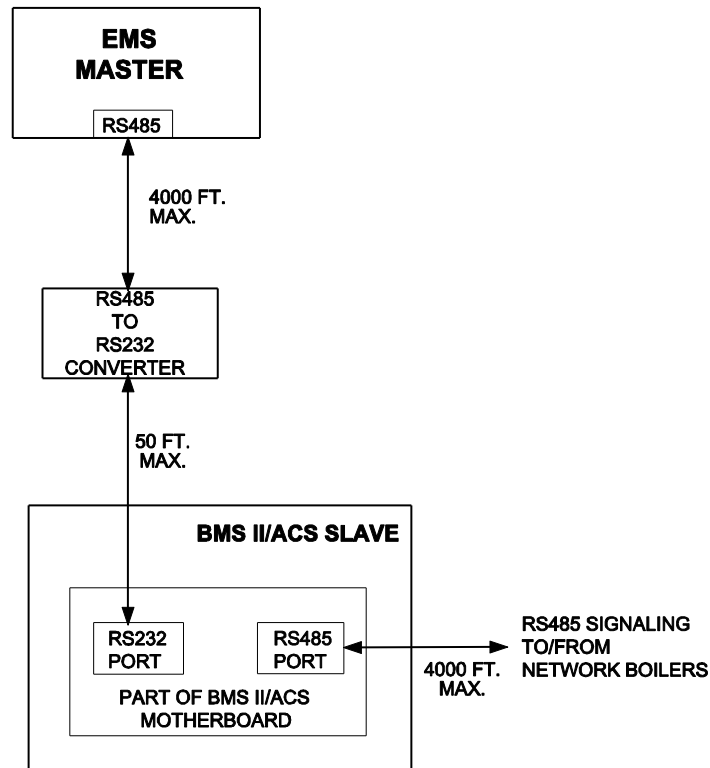

Figure 4-5: BMS II/ACS With Wiring Compartment Cover Removed



EMS RS232 Port to BMS II/ACS RS232 Port



EMS RS485 Port to BMS II/ACS RS232 Port Using External Converter

Figure 4-6: EMS Master To BMS II/ACS Slave Connection Diagrams (Sheet 1 of 2)

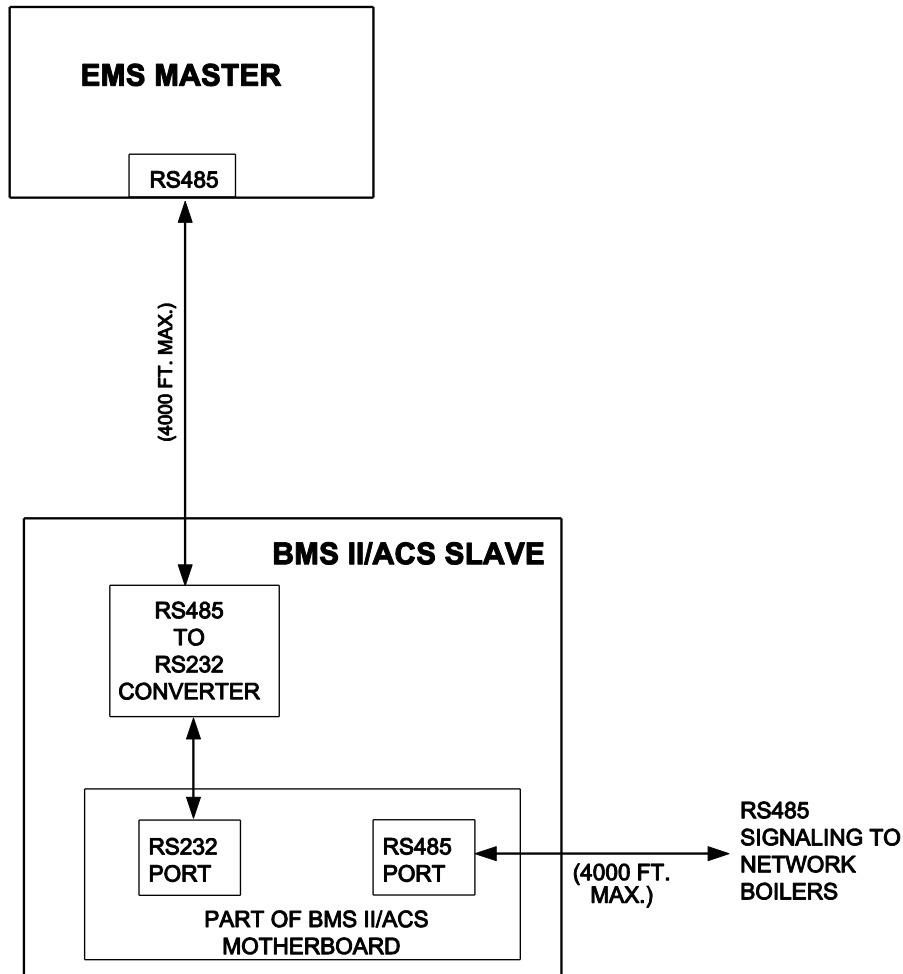

EMS to BMS II/ACS with External RS485-TO-RS232 Converter

Figure 4-6: EMS Master To BMS II/ACS Slave Connection Diagrams (Sheet 2 of 2)

4.2.3 BMS/BMS II/ACS Master To C-More Boiler Controller Slaves

Wiring connections for Modbus operation between a BMS/BMS II/ACS Master and C-More Boiler Controller Slaves are made between the BMS/BMS II/ACS internal RS485 Port terminals and the I/O Box for the associated C-More Boiler Controller. The RS485 Port terminals for the BMS and BMS II/ACS are shown in Figure 4-4 and 4-5 respectively. The RS485 COMM connections at each Boiler’s I/O Box are shown in Figure 4-7. Identical I/O Boxes are used for both Benchmark and KC1000 Boilers.

CHAPTER 4: Modbus Network Hardware Setup & Installation

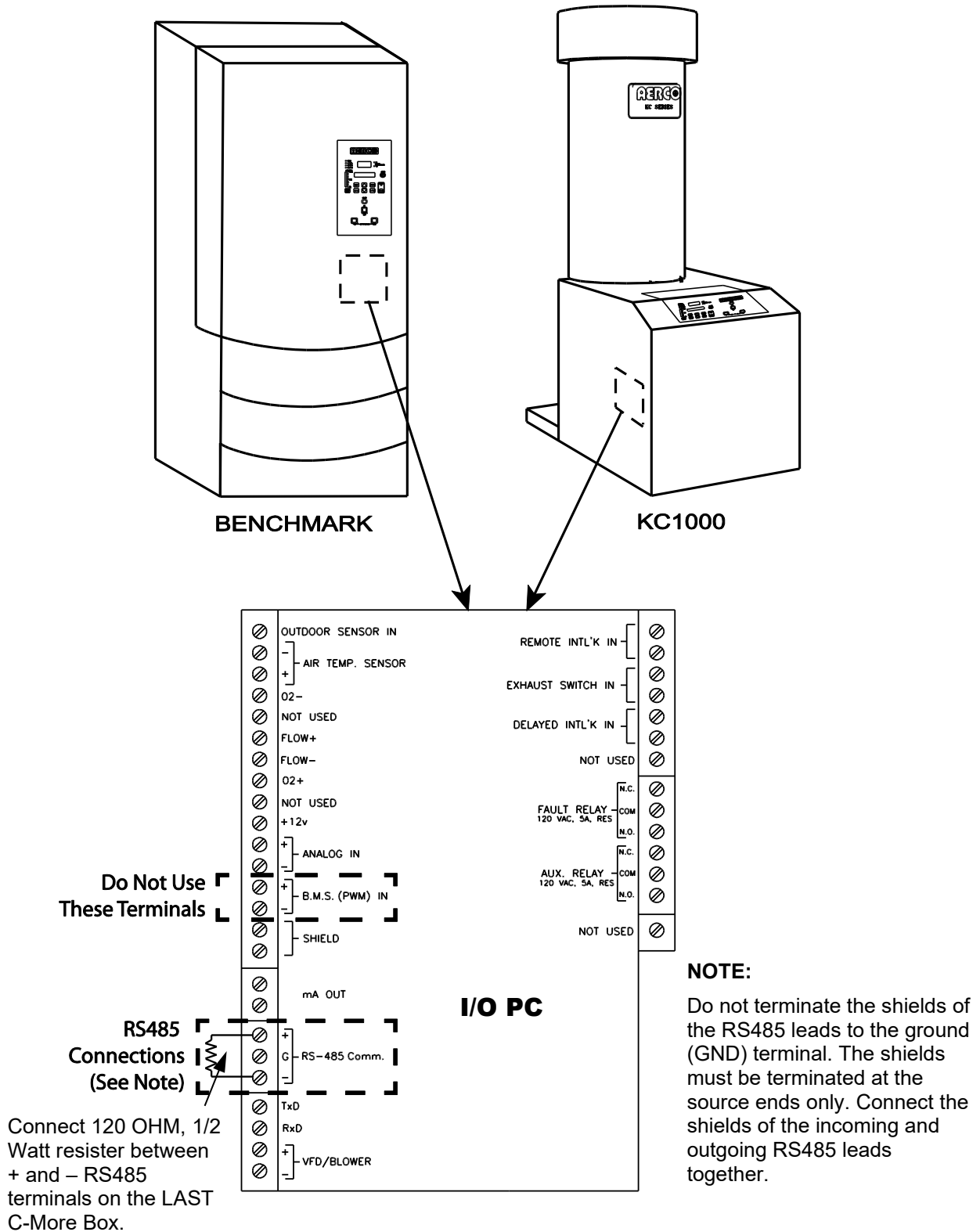

Figure 4-7: I/O Box RS485 COMM Terminal Connections

4.2.4 C-More Slaves To BMS/BMS II/ACS or EMS Master

Wiring connections between a BMS/BMS II/ACS Master and up to 32 Network C-More Boiler Controller Slaves are made directly between the BMS/BMS II/ACS internal RS485 terminals (Figure 4-4 or 4-5) and the RS485 COMM terminals in each Boiler's I/O Box (Figure 4-7).

If a third-party EMS Master is used in place of the BMS/BMS II/ACS, the Modbus Network connections will depend on the available communication port(s) on the EMS. Many EMS Models contain only a RS232 (DB9) port, while others contain either a 2-Wire or 4-Wire RS485 port. Some EMS models contain both a RS232 and a RS485 port. If the EMS is equipped with only a RS232 port, a RS232-to-RS485 converter will be required (such as a B&B Electronics, Model 485SD9TB).

4.3 RS485 Loop Terminating Resistors and Bias

A terminating resistor (120 ohms) on each end of the RS485 loop is designed to match the electrical impedance characteristic of the twisted-pair loop and prevent echoes or cross-talk from corrupting data on the line.

Bias may be necessary on the RS485 loop to minimize noise on the circuit. Loop bias is accomplished by activating pull-up/pull-down resistors on the last C-More Boiler Controller in the chain. Do not activate the bias DIP switches on the BMS II/ACS when the C-More bias is used

AERCO requires that both terminating resistors and bias be implemented on the RS485 circuit as described in paragraphs 4.3.1 and 4.3.2 which follow.

4.3.1 BMS Terminating Resistor

Each BMS/BMS II/ACS is equipped with a built-in terminating resistor (120 ohms) on the RS485 port. Therefore, only one additional terminating resistor will be required at the other end of the RS485 loop. Ensure that the last C-More Boiler Controller Slave on the loop has its terminating resistor activated as described in paragraph 4.3.2.

4.3.2 C-More Boiler Controller Terminating Resistor and Bias

C-More Boiler Controllers can function only as Slave devices on a Modbus Network. Since the Slaves are connected in a "Daisy-Chain" configuration, the terminating resistor must be enabled only in the last C-More Boiler Controller in the chain. In addition, bias must also be implemented only in the last C-More Boiler Controller. This is accomplished by setting a DIP switches on the Primary Micro-Controller (PMC) Board contained in the applicable C-More Boiler Controller. The last unit in the chain must be energized (even if disabled) to enable bias. To activate the DIP switches, proceed as follows:

1. Remove power from the last C-More Boiler Controller in the RS485 loop.
2. Loosen and remove the four (4) screws securing the front panel assembly to the chassis as shown in Figure 4-8.
3. Carefully separate the panel from the chassis. Use care to avoid applying undue stress to the ribbon cable connected between the back of the panel and the chassis-mounted printed circuit boards.

CAUTION:

The C-More Boiler Controller Printed Circuit Boards contain electronic components that are sensitive to electrostatic discharge (ESD). Prior to performing the following steps, put on an anti-static wrist strap and connect the clip lead to earth ground. Failure to observe this precaution may result in permanent damage to on-board ESD-sensitive components.

4. Put on an anti-static wrist strap and attach the clip lead to earth ground.
5. From the back of the Panel Assembly (Figure 4-9), locate the RS485 DIP switches on the PMC Board.
6. Refer to Figure 4-10 and set the “TERM” switch to the ON (Up) position.
7. Set the BIAS2 and BIAS1 switches to the ON (Up) position.
8. After the DIP switches have been set, reposition the Front Panel Assembly on the chassis and secure it in place with the four screws.

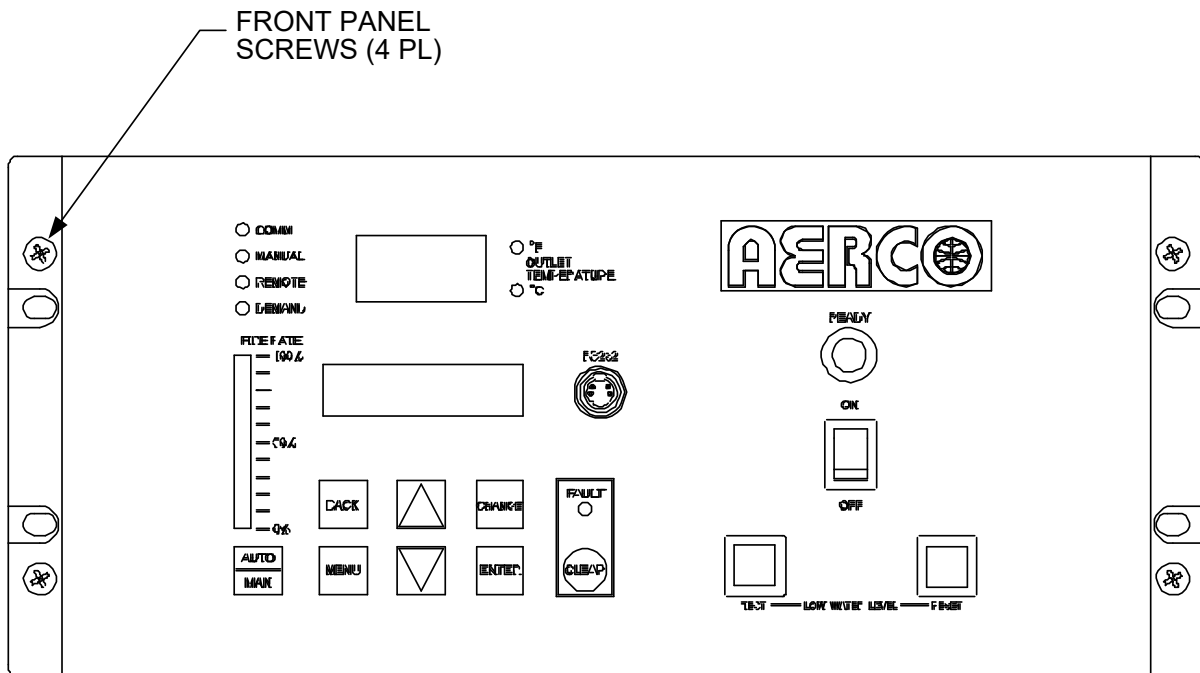

NOTE:

THE C-MORE CONTROLLER MODEL SHOWN WITH A HORIZONTAL PANEL CONTROL LAYOUT IS USED ON KC1000 BOILERS.
 BENCHMARK BOILERS UTILIZE C-MORE CONTROLLERS WITH A VERTICAL PANEL CONTROL LAYOUT.

Figure 4-8: C-More Control Panel - Front View

CHAPTER 4: Modbus Network Hardware Setup & Installation

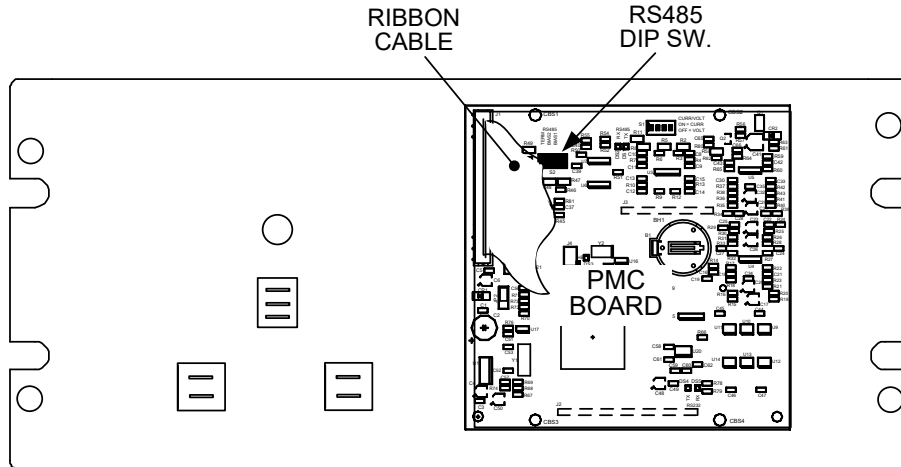

CONTROL PANEL REAR VIEW – KC1000

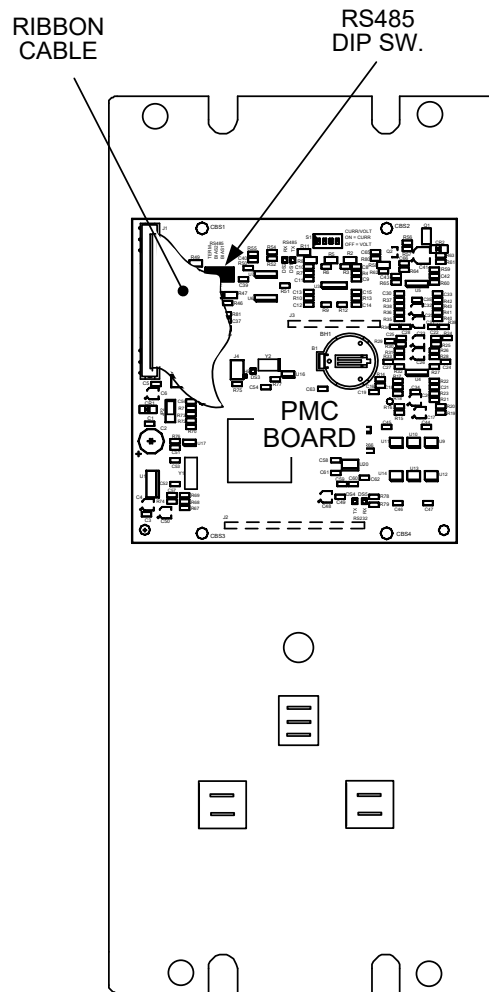

CONTROL PANEL REAR VIEW – BENCHMARK

Figure 4-9: C-More Control Panel - Rear Views

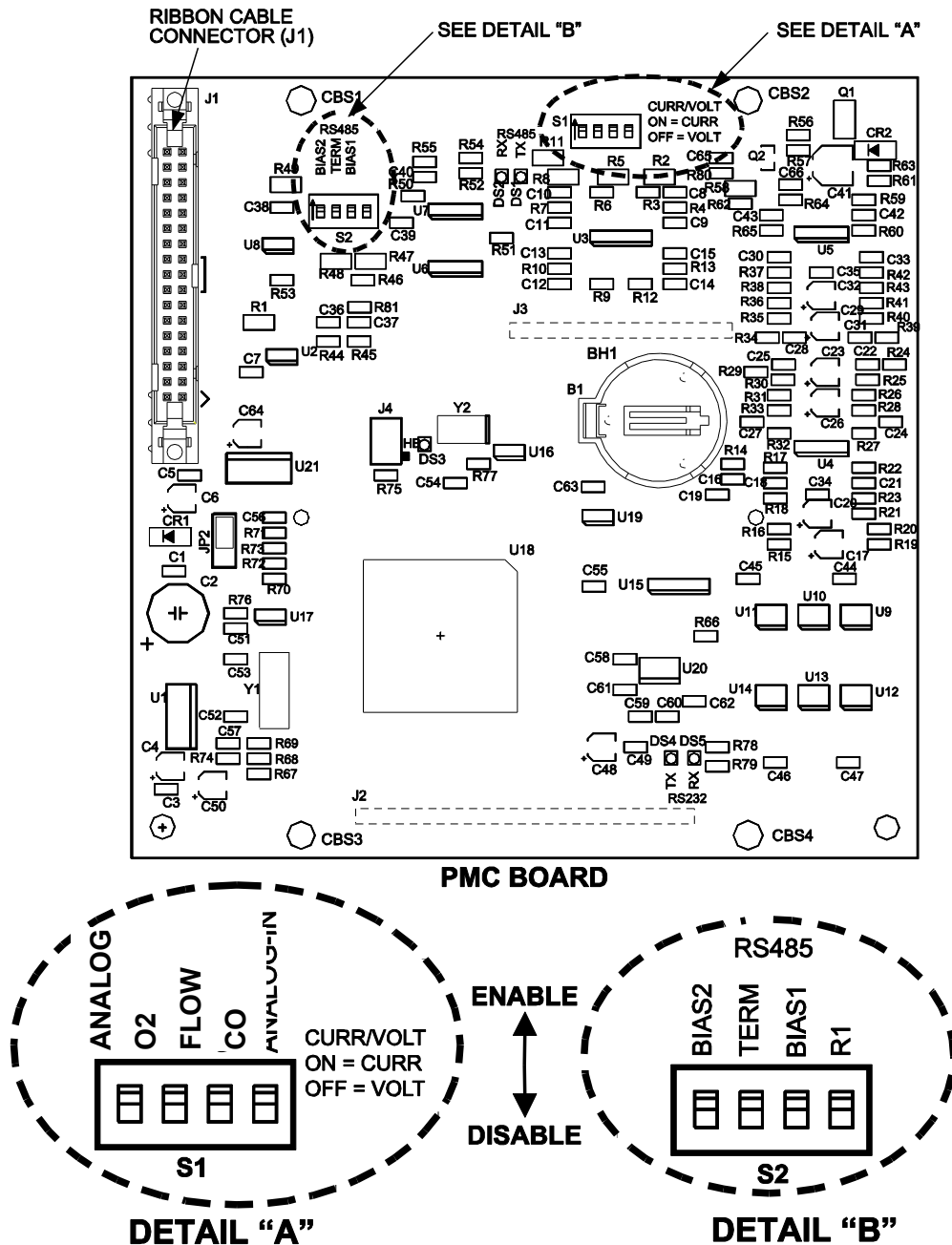

S1: These DIP Switches are used to set either current (CURR) or voltage (VOLT) as the remote signal input source.
 ON (up) = CURRENT
 OFF (down) = VOLTAGE
NOTE:
 Refer to GF-114 before activating any of the DIP switches.

S2: The BIAS2, TERM, and BIAS1 DIP switches are used only when this is the last unit connected at the end of a RS485 (Modbus) network chain. If an Oxygen Sensor is attached to the C-More Controller, set R1 to DISABLED (down). If an Oxygen Sensor is NOT used, set R1 to ENABLED (up). Factory default is ENABLED.

Figure 4-10: C-More Control Panel PMC Board

4.4 Modbus Network Wiring Diagrams

Sample Modbus Network wiring diagrams for the basic circuit configurations are provided in paragraphs 4.4.1 through 4.4.3. It should be noted that these diagrams are only intended as a guide and do not include all possible scenarios. If a third-party EMS is being utilized, refer to the manufacturer's manual prior to attempting any network wiring connections.

CAUTION:

It is imperative that polarity be maintained between all Modbus Network connections. The Network will not operate if the proper polarity is not maintained. Also, twisted-pair wiring shield should only be terminated at the controlling Master Controller for the Modbus Network.

4.4.1 Wiring Diagrams for Master EMS Controlling BMS Slaves With Legacy (PWM) Boilers

Figure 4-11 provides a sample wiring diagram for a BMS (Model 168) being controlled by an EMS Master equipped with a RS485 port.

4.4.2 Wiring Diagram for Master BMS/BMS II/ACS Controlling Networked C-More Slaves

Wiring connections for the "Network" Boilers are made at the BMS/BMS II/ACS RS485 port as shown in Figure 4-12. In addition, for a BMS (only) up to 8 "Legacy" Boilers can be wired to the PWM terminal strip to allow control of up to 40 Boilers by one BMS. The BMS PWM terminal connections can also be used to connect AERCO Boilers which utilize older types of control systems, such as Modular Control Boxes, or C-More Controllers equipped with software version 1.61 or lower. Refer to BMS Manual GF-108M for additional setup details for the PWM "Legacy" Boilers. BMS II and ACS units do not support PWM, therefore disregard the PWM terminal connections shown in Figure 4-12. BMS II/ACS units can only operate networked boilers with C-More control systems.

4.4.3 Wiring Diagram For EMS Master Controlling C-More Controller Slaves

Figure 4-13 provides a sample wiring diagram for an EMS equipped with a RS485 port. If the EMS contains a 4-wire RS485 port, refer to Figure 4-11, Detail "A" for additional wiring details.

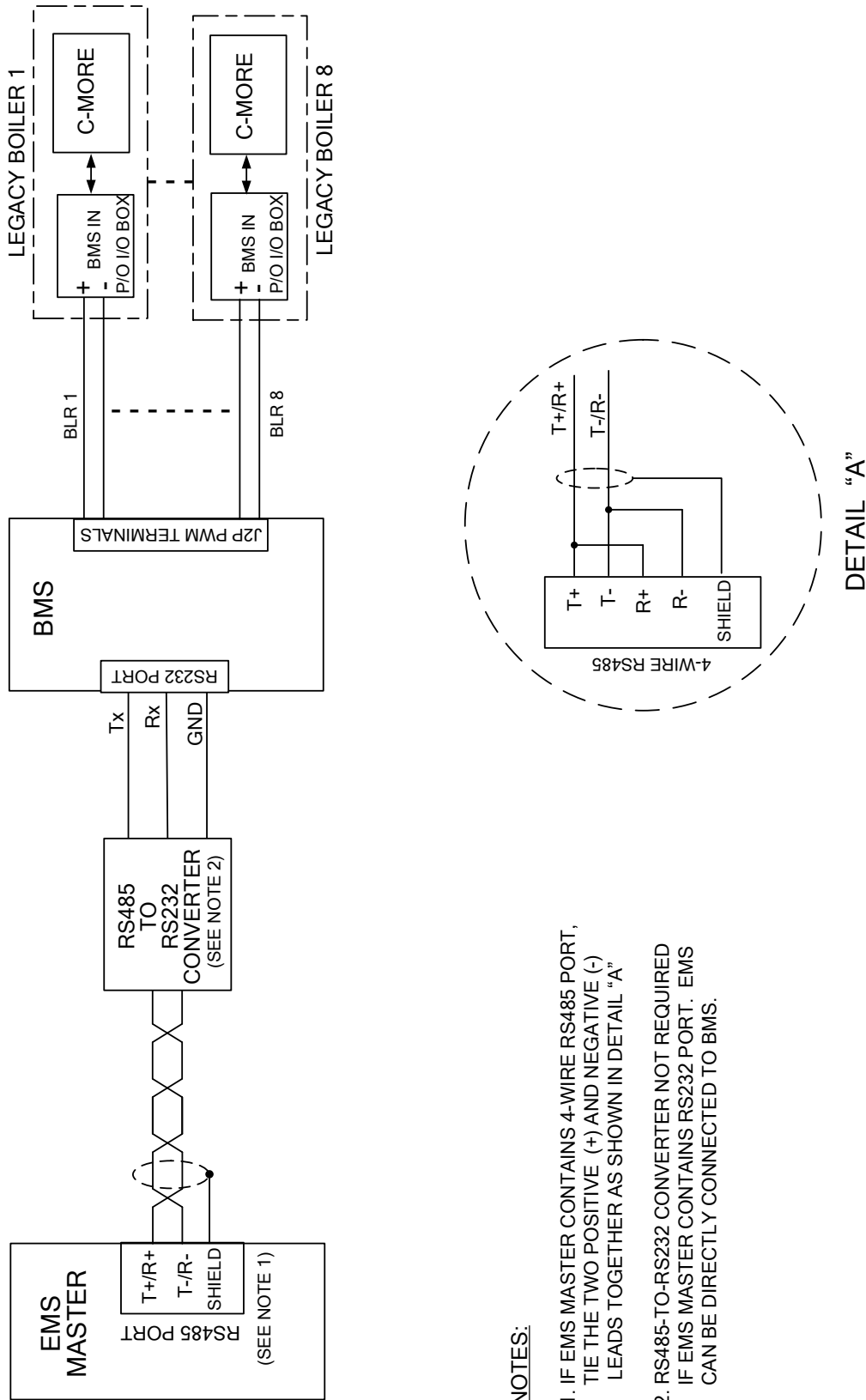

NOTES:

1. IF EMS MASTER CONTAINS 4-WIRE RS485 PORT, TIE THE TWO POSITIVE (+) AND NEGATIVE (-) LEADS TOGETHER AS SHOWN IN DETAIL "A"
2. RS485-TO-RS232 CONVERTER NOT REQUIRED IF EMS MASTER CONTAINS RS232 PORT. EMS CAN BE DIRECTLY CONNECTED TO BMS.

Figure 4-11. EMS Master Controlling BMS Slave

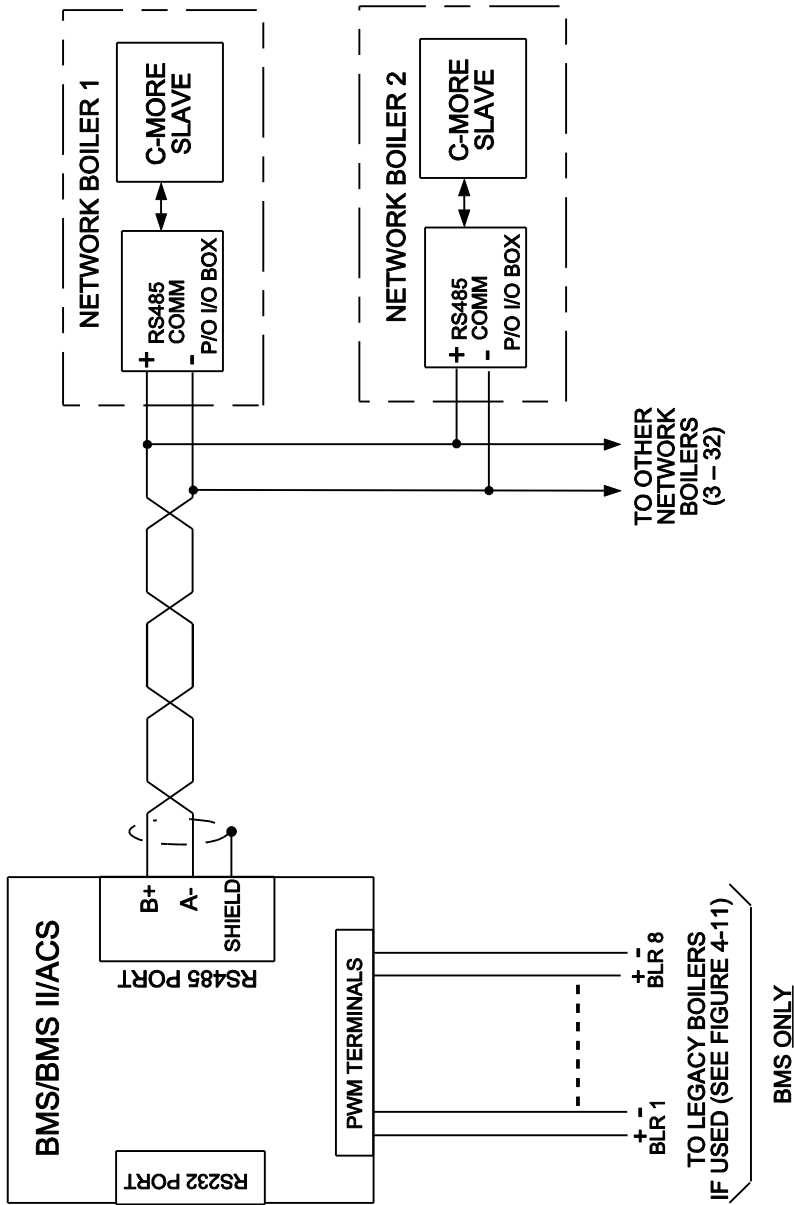

NOTE
 THE LAST C-MORE SLAVE ON THE RS485 LOOP MUST HAVE ITS TERMINATION RESISTOR (TERM) AND BIAS (BIAS1, BIAS2) DIP SWITCHES TURNED ON.

Figure 4-12. BMS Master Controlling C-More Slaves

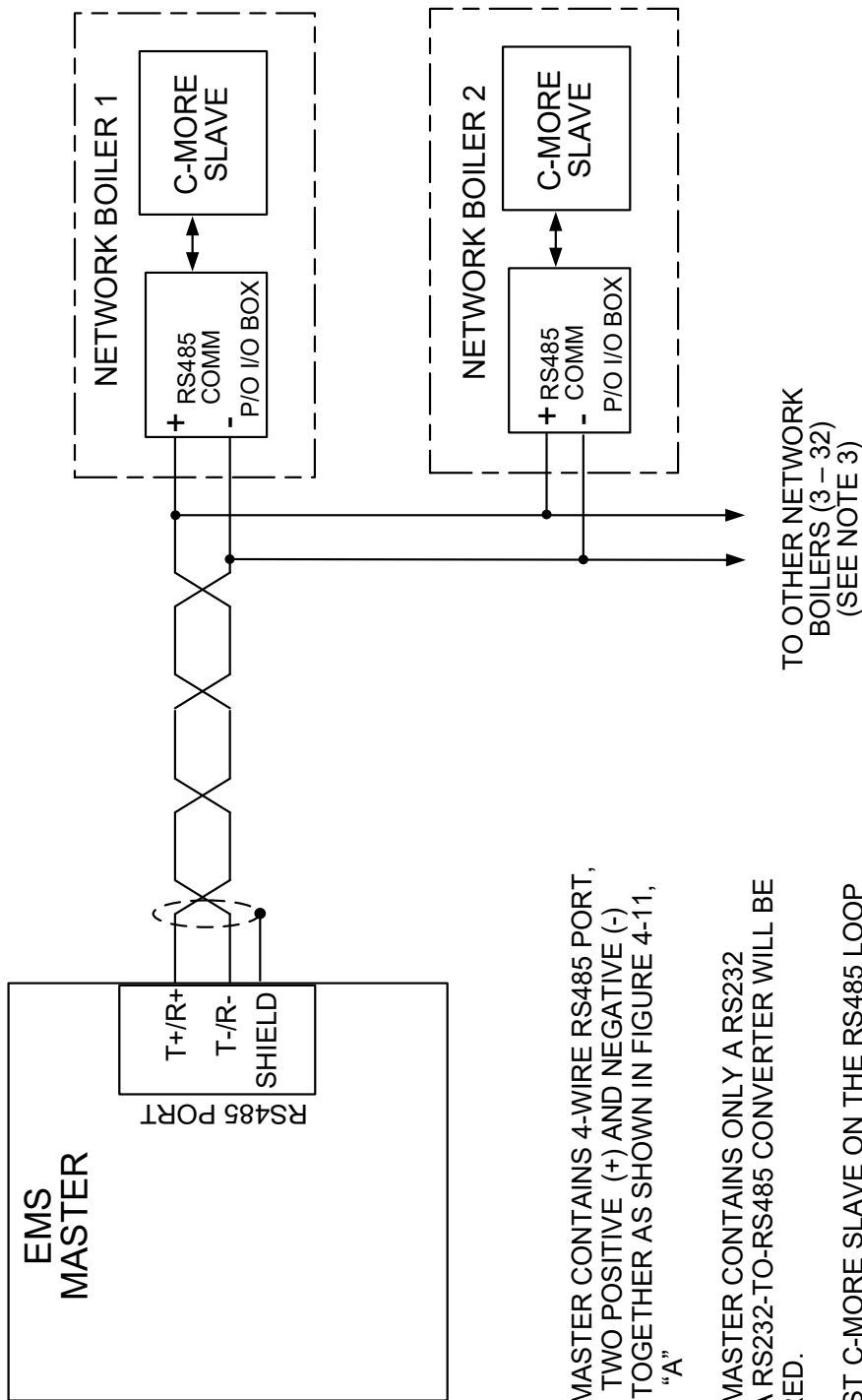

NOTES:

1. IF EMS MASTER CONTAINS 4-WIRE RS485 PORT, TIE THE TWO POSITIVE (+) AND NEGATIVE (-) LEADS TOGETHER AS SHOWN IN FIGURE 4-11, DETAIL "A"
2. IF EMS MASTER CONTAINS ONLY A RS232 PORT, A RS232-TO-RS485 CONVERTER WILL BE REQUIRED.
3. THE LAST C-MORE SLAVE ON THE RS485 LOOP MUST HAVE ITS TERMINATION RESISTOR (TERM) TURNED ON. ALSO, BIAS (BIAS1, BIAS2) MAY BE REQUIRED. CHECK WITH THE EMS MANUFACTURER.

Figure 4-13. EMS Master Controlling C-More Slaves

(This page intentionally blank)

CHAPTER 5. MODBUS SOFTWARE SETUP: C-MORE & BMS

NOTES:

Section 5 provides Modbus Software Setup information for BMS (Model 168) units only. Refer to Section 6 for Modbus Software Setup information for BMS II and ACS units.

The BMS includes a Modbus Pass-Thru function which permits an EMS to monitor and configure the boilers on the Modbus network. However, it does not permit the EMS to directly control the boilers. This Modbus Pass-Thru feature is enabled in the BMS Field Adjust Menu using the AIR TEMP key. Refer to BMS Manual GF-108M, paragraph 4.3.2 and Appendix D for details.

5.1 Introduction

This Section provides the information necessary to configure the AERCO C-More Boiler Controllers and a Boiler Management System (BMS) for operation on a Modbus Network. It also provides the basic setup procedures to operate the C-More Boiler Controller and BMS in each available Modbus Mode.

5.2 C-More Boiler Controller Setup For Modbus Operation

The C-More Boiler Controller can be set up for three types of Modbus operating modes. These modes are as follows:

- Monitoring and Configuration Only
- Modbus Direct Drive Control and Monitoring
- Modbus Remote Setpoint Control and Monitoring

The following paragraphs provide the procedures necessary to set up the C-More Boiler Controllers for each of the above modes of operation. These procedures assume that the required wiring connections for Modbus operation have already been accomplished as described in Section 4.

NOTE:

The appropriate password must be entered in the Setup Menu of the C-More Boiler Controller, prior to changing any of the current settings. For detailed information on menu items, refer to the appropriate Operation and Maintenance Manual for the Benchmark Series or KC1000 Series units being used.

5.2.1 Monitoring and Configuration Control

In order for the C-More Boiler Controller to be recognized by the Modbus Master, a valid Network Comm Address must be entered in the Setup Menu as follows:

NOTE:

A C-More Boiler Controller can be monitored or configured on the Modbus Network regardless of its mode of control.

1. Scroll through the Setup Menu until *Comm Address* is displayed.
2. With *Comm Address* displayed, press the **CHANGE** key.
3. Using the ▲ or ▼ arrow key, enter the appropriate *Comm Address* from 1 to 127.
4. Press the **ENTER** key to store the *Comm Address* in memory.

Once the *Comm Address* has been entered, the C-More Boiler Controller can be accessed by the Modbus Network Master (BMS or EMS).

5.2.2 Modbus Direct Drive Control and Monitoring

Modbus Direct Drive Control of the C-More Boiler Controller is set up as follows:

1. Enter and store a valid Comm Address using the procedures in paragraph 5.2.1.
2. Scroll through the Configuration Menu and change the following menu options to the settings shown:

<u>MENU OPTION</u>	<u>SETTING</u>
Boiler Mode	Direct Drive
Remote Signal	Network

3. The C-More Controller is now set for Direct Drive operation via the Modbus Network.
4. AERCO recommends that the *Setpoint Limiting* feature in the Configuration Menu be enabled. Also, ensure that the *Failsafe Mode* setting is set to the desired setting (*Shutdown* or *Constant Setpoint*) in the event that the Modbus Network signal is lost.

5.

5.2.3 Modbus Remote Setpoint Control

Modbus Remote Setpoint Control of the C-More Boiler Controller is set up as follows:

1. Enter and store a valid Comm Address using the procedures in paragraph 5.2.1.
2. Scroll through the Configuration Menu and change the following menu options to the settings shown:

<u>MENU OPTION</u>	<u>SETTING</u>
Boiler Mode	Remote Setpoint
Remote Signal	Network

3. The C-More Controller is now set for Remote Setpoint operation via the Modbus Network.
4. AERCO recommends that the *Setpoint Limiting* feature in the Configuration Menu be enabled. Also, ensure that the *Failsafe Mode* setting is set to the desired setting (*Shutdown* or *Constant Setpoint*) in the event that the Modbus Network signal is lost.

NOTE:

The AERCO BMS can function as either a Slave or a Master on a Modbus Network. Paragraph 5.3 provides the programming setup procedures when the BMS is a Slave to an EMS (or BAS). Paragraph 5.4 provides the programming setup procedures when the BMS is the controlling Master for C-More Boiler Controllers.

5.3 BMS Setup For Operation As a Slave to an EMS Master

The BMS can be programmed as a Slave to an EMS Master on the Modbus Network in two ways:

- Monitoring and Configuration Only
- Modbus Remote Setpoint Control and Monitoring

The setup procedures for the above operating configurations are provided in paragraphs 5.3.1 and 5.3.2 which follow.

5.3.1 BMS Monitoring and Configuration By An EMS Master

To set up the BMS to be monitored or configured on the Modbus Network, proceed as follows:

1. Press the **FIELD ADJ** key on the BMS front panel to enter the Field Adjust Mode. The yellow LED on the key should be lit.
2. Press the **AIR TEMP** key until *RS232 MODE* is shown on the top line of the display. If necessary, press the ▲ or ▼ arrow key until *MODBUS SLAVE* appears in the second line of the display.
3. Press the **AIR TEMP** key again until *RS232 BAUDRATE* is shown on the top line of the display. Press the ▲ or ▼ arrow key to select the appropriate baud rate.
4. Press the **AIR TEMP** key again until *MODBUS ADDRESS* is shown on the top line of the display. Press the ▲ or ▼ arrow key to set the desired address for the BMS on the Modbus Network.
5. Press the **FIELD ADJ** key to exit the Field Adjust Mode. The yellow LED on the key should go off.

The BMS is now set up to be monitored or configured on the Modbus Network. Remember that the configuration can only be changed on the Modbus Network by first entering a valid password for PASSWORD LO and PASSWORD HI.

5.3.2 BMS Modbus Remote Setpoint Control By An EMS Master

To configure the BMS for Remote Setpoint Control from an EMS Master, proceed as follows:

1. Press the **FIELD ADJ** key on the BMS front panel to enter the Field Adjust Mode. The yellow LED on the key should be lit.
2. Press the **AIR TEMP** key until *RS232 MODE* is shown on the top line of the display. If necessary, press the ▲ or ▼ arrow key until *MODBUS SLAVE* appears in the second line of the display.
3. Press the **AIR TEMP** key again until *RS232 BAUDRATE* is shown on the top line of the display. Press the ▲ or ▼ arrow key to select the appropriate baud rate.
4. Press the **AIR TEMP** key again until *MODBUS ADDRESS* is shown on the top line of the

CHAPTER 5: Modbus Software Setup: C-More & BMS

display. Press the ▲ and ▼ arrow keys to set the required address for the BMS on the Modbus Network.

5. Press the **AIR TEMP** key again until *NETWORK TIMEOUT* is shown in the top line of the display. Press the ▲ and ▼ arrow keys to select the maximum allowable time (in seconds) for the EMS (or BAS) to refresh the Remote Setpoint information being sent to the BMS. AERCO recommends that a time be selected that is at least 3 times the normal refresh rate. This will allow for the loss of 1 or 2 transmissions without timing out.
6. Press the **AIR TEMP** key again until *REMOTE SIGNAL* is shown in the top line of the display. Press the ▲ or ▼ arrow key to select *MODBUS*.
7. Press the **FIELD ADJ** key to exit the Field Adjust Mode. The yellow LED on the key should go off.
8. To set the BMS for Remote Operation, press the **CONFIG SYS** key to enter the System Configuration Mode. The red LED on the key will light.
9. Press the **FIELD ADJ** key until *HDR SET MODE* is shown in the top line of the display. Press the ▲ and ▼ arrow keys to select *REMOTE SET TEMP*.
10. Press the **CONFIG SYS** key to exit the System Configuration Mode. The red LED on the key will go off.

The BMS is now programmed for Remote Setpoint Operation from an EMS Master. In the event of a Modbus signal interruption, AERCO recommends that the *TEMP FAIL MODE* setting be set to *Switch Inputs* if you want the BMS to continue running the Boilers in the CONSTANT SET TEMP Mode. In this case, ensure that the *REF TEMP* is set to the desired setpoint temperature.

5.4 BMS Setup As Master To C-More Boiler Controllers

To set up the BMS as a Master to Control C-More Boiler Slaves, proceed as follows:

1. Press the **FIELD ADJ** key on the BMS front panel to enter the Field Adjust Mode. The yellow LED on the key should be lit.
2. Press the **HDR TEMP** key until *RS485 BAUDRATE* is shown on the top line of the display. Press the ▲ and ▼ arrow keys if necessary to set the baud rate to 9600.
3. Press the **HDR TEMP** key again until *MIN SLAVE ADDR* is shown in the display. Use the ▲ and ▼ arrow keys to set the address to zero.
4. Press the **HDR TEMP** key again until *MAX SLAVE ADDR* is shown in the display. Use the ▲ and ▼ arrow keys to set the address to zero.
5. Press the **HDR TEMP** key until *NUMBER NETW BLRS* is shown on the top line of the display. Using the ▲ and ▼ arrow keys, set the number to the maximum number of C-More Boilers that will be controlled on this Modbus Network.

NOTE:

DO NOT count the C-More Boilers or Water Heaters that will only be monitored on the Modbus Network. Only count the Boilers that will be controlled by the BMS using the Modbus connection.

6. Press the **HDR TEMP** key until *MODBUS CNTL TYPE* is shown on the top line of the display. Using the ▲ or ▼ arrow key, if necessary, set it to *ROUND ROBIN*.
7. Press the **HDR TEMP** key until *NETW BOILER 1* is shown on the top line of the display. Use the ▲ and ▼ arrow keys to set the address of the first Boiler being controlled on the BMS RS485 loop. (This address must be the same as the Comm Address setting in the

C-More Boiler Controller).

8. Press the **HDR TEMP** key again until *NETW BOILER 2* is shown on the top line of the display. Use the ▲ and ▼ arrow keys to set the address of the second Boiler being controlled on the BMS RS485 loop. (This address must be the same as the Comm Address setting in the C-More Boiler Controller).
9. Repeat step 8 for each additional C-More Boiler being controlled on the BMS RS485 loop.
10. This completes programming for the BMS RS485 Network. Press the **FIELD ADJ** key to exit the Field Adjust Mode. The yellow LED on the key should go off.

IMPORTANT

Boilers #1 to #8 are reserved for the Legacy Boilers connected to the Pulse Width Modulation (PWM) connections on the BMS. Therefore, *NETW BOILER 1* is the same as Boiler #9. *NETW BOILER 2* is the same as Boiler #10 and so on.

The BMS is now programmed to control the Networked Boilers, as well as any Legacy Boilers connected to it. The BMS will automatically detect any C-More Boiler that is programmed for Network Control as follows:

- Boiler Mode = Direct Drive
- Remote Signal = Network
- Comm Address = Matches one of the *NETW BOILER* addresses stored in the BMS

(This page intentionally blank)

CHAPTER 6. MODBUS SOFTWARE SETUP: C-MORE & BMS II/ACS

NOTES:

Section 6 provides Modbus Software Setup information for BMS II and ACS units only. Refer to Section 5 for Modbus Software Setup information for BMS (Model 168) units.

The BMS II/ACS includes a Modbus Pass-Thru function which permits an EMS to monitor and configure the boilers on the Modbus network. However, it does not permit the EMS to directly control the boilers. This Modbus Pass-Thru feature is enabled in the BMS II/ACS RS232 Menu. Refer to BMS II Manual GF-124 or ACS Manual GF-131, paragraph 3.6, and Appendix A for details.

6.1 Introduction

This Section provides the information necessary to configure the AERCO C-More Boiler Controllers and a Boiler Management System II (BMS II)/AERCO Control System (ACS) for operation on a Modbus Network. It also provides the basic setup procedures to operate the C-More Boiler Controller and BMS II in each available Modbus Mode.

6.2 C-More Boiler Controller Setup For Modbus Operation

The C-More Boiler Controller can be set up for three types of Modbus operating modes. These modes are as follows:

- Monitoring and Configuration Only
- Modbus Direct Drive Control and Monitoring
- Modbus Remote Setpoint Control and Monitoring

The following paragraphs provide the procedures necessary to set up the C-More Boiler Controllers for each of the above modes of operation. These procedures assume that the required wiring connections for Modbus operation have already been accomplished as described in Section 4.

NOTE:

The appropriate password must be entered in the Setup Menu of the C-More Boiler Controller, prior to changing any of the current settings. For detailed information on menu items, refer to the appropriate Operation and Maintenance Manual for the Benchmark Series or KC1000 Series units being used.

6.2.1 Monitoring and Configuration Control

In order for the C-More Boiler Controller to be recognized by the Modbus Master, a valid Network Comm Address must be entered in the Setup Menu as follows:

NOTE:

CHAPTER 6: Modbus Software Setup: C-More & BMSII/ACS

A C-More Boiler Controller can be monitored or configured on the Modbus Network regardless of its mode of control.

1. Scroll through the Setup Menu until *Comm Address* is displayed.
2. With *Comm Address* displayed, press the **CHANGE** key.
3. Using the ▲ or ▼ arrow key, enter the appropriate *Comm Address* from 1 to 127.
4. Press the **ENTER** key to store the *Comm Address* in memory.

Once the *Comm Address* has been entered, the C-More Boiler Controller can be accessed by the Modbus Network Master (BMS II/ACS or EMS).

6.2.2 Modbus Direct Drive Control and Monitoring

Modbus Direct Drive Control of the C-More Boiler Controller is set up as follows:

1. Enter and store a valid Comm Address using the procedures in paragraph 6.2.1.
2. Scroll through the Configuration Menu and change the following menu options to the settings shown:

<u>MENU OPTION</u>	<u>SETTING</u>
Boiler Mode	Direct Drive
Remote Signal	Network

3. The C-More Controller is now set for Direct Drive operation via the Modbus Network.
4. AERCO recommends that the *Setpoint Limiting* feature in the Configuration Menu be enabled. Also, ensure that the *Failsafe Mode* setting is set to the desired setting (*Shutdown* or *Constant Setpoint*) in the event that the Modbus Network signal is lost.

5.

6.2.3 Modbus Remote Setpoint Control

Modbus Remote Setpoint Control of the C-More Boiler Controller is set up as follows:

1. Enter and store a valid Comm Address using the procedures in paragraph 6.2.1.
2. Scroll through the Configuration Menu and change the following menu options to the settings shown:

<u>MENU OPTION</u>	<u>SETTING</u>
Boiler Mode	Remote Setpoint
Remote Signal	Network

3. The C-More Controller is now set for Remote Setpoint operation via the Modbus Network.
4. AERCO recommends that the *Setpoint Limiting* feature in the Configuration Menu be enabled. Also, ensure that the *Failsafe Mode* setting is set to the desired setting (*Shutdown* or *Constant Setpoint*) in the event that the Modbus Network signal is lost.

NOTE:

The AERCO BMS II/ACS can function as either a Slave or a Master on a Modbus Network. Paragraph 6.3 provides the programming setup procedures when the BMS II/ACS is a Slave to an EMS (or BAS). Paragraph 6.4 provides the programming setup procedures when the BMS II/ACS is the controlling Master for C-More Boiler Controllers.

The appropriate password must be entered in the Setup Menu of the BMS II/ACS prior to changing any of the current settings. For detailed information on menu items or change procedures, refer to the BMS II/ACS operating instructions provided in GF-124.

6.3 BMS II/ACS Setup For Operation As a Slave To an EMS Master

The BMS II/ACS can be programmed as a Slave to an EMS Master on the Modbus Network in two ways:

- Monitoring and Configuration Only
- Modbus Remote Setpoint Control and Monitoring

The setup procedures for the above operating configurations are provided in paragraphs 6.3.1 and 6.3.2 which follow.

6.3.1 BMS II/ACS Monitoring and Configuration By An EMS Master

To set up the BMS II/ACS to be monitored or configured on the Modbus Network, entries must be made in the RS232 Menu as follows:

1. Using the **MENU** key on the BMS II/ACS front panel, select the RS232 MENU.
2. Scroll through the RS232 Menu and select the *RS232 MODE* option. The second line of the display will show the currently selected RS232 Mode (*MODBUS SLAVE* or *NORMAL*).
3. If *MODBUS SLAVE* is not displayed, press the **CHANGE** key and toggle the display to *MODBUS SLAVE*.
4. Press the **ENTER** key to store the *MODBUS SLAVE* setting in memory.
5. While still in the RS232 MENU, scroll to the *RS232 BAUDRATE* option. Using the **CHANGE** key and **▲** or **▼** arrow keys, select the appropriate baud rate being used on the Modbus Network. Press the **ENTER** key to store the selected baud rate.
6. Next, scroll to the *MODBUS ADDRESS* option. Using the **CHANGE** key, and the **▲** or **▼** arrow keys, select the desired address for the BMS II/ACS on the Modbus Network.
7. When the address is selected, press the **ENTER** key to store the address in memory.

The BMS II/ACS is now set up to be monitored or configured on the Modbus Network.

6.3.2 BMS II/ACS Modbus Remote Setpoint Control By An EMS Master

To configure the BMS II/ACS for Remote Setpoint Control from an EMS Master, options must be set in the RS232 Menu and Field Adjust Menu as follows:

1. Using the **MENU** key on the BMS II/ACS front panel, select the RS232 MENU.
2. Scroll through the RS232 Menu and select the *RS232 MODE* option. The second line of the display will show the currently selected RS232 Mode (*MODBUS SLAVE* or *NORMAL*).
3. If *MODBUS SLAVE* is not displayed, press the **CHANGE** key and toggle the display to *MODBUS SLAVE*.
4. Press the **ENTER** key to store the *MODBUS SLAVE* setting in memory.
5. While still in the RS232 MENU, scroll to the *RS232 BAUDRATE* option. Using the **CHANGE**, **▲** and **▼** arrow keys, select the appropriate baud rate being used on the Modbus Network. Press the **ENTER** key to store the selected baud rate.
6. Scroll to the *MODBUS ADDRESS* option in the RS232 MENU. Using the **CHANGE** key, and the **▲** and **▼** arrow keys, select the desired address for the BMS II/ACS on the Modbus Network. When the address is selected, press the **ENTER** key to store the address in memory.

CHAPTER 6: Modbus Software Setup: C-More & BMSII/ACS

7. Next, scroll to the *NETWORK TIMEOUT* option in the RS232 MENU. Press the **CHANGE** key and then select the maximum allowable time (in seconds) for the EMS (or BAS) to refresh the Remote Setpoint information being sent to the BMS II/ACS. AERCO recommends that a time be selected that is at least 3 times the normal refresh rate. This will allow for the loss of 1 or 2 transmissions without timing out. This completes the required entries in the RS232 MENU.
8. Press the **MENU** key and enter the FIELD ADJUST MENU.
9. Using the **▲** and **▼** arrow keys, scroll through the FIELD ADJUST MENU until the *HDR SET MODE* option is displayed.
10. If *REMOTE SETPT* is not shown in the second line of the display, press the **CHANGE** key and toggle the display to *REMOTE SETPT*.
11. Press the **ENTER** key to store the *REMOTE SETPT* setting.
12. While still in the FIELD ADJUST MENU, scroll to the *REMOTE SIGNAL* option.
13. If *MODBUS* is not shown in the second line of the display, press the **CHANGE** key and toggle the display to *MODBUS*.
14. Press the **ENTER** key to store the setting.
15. This completes all required menu entries for this mode.

The BMS II/ACS is now programmed for Remote Setpoint Operation from an EMS Master. In the event of a Modbus signal interruption, AERCO recommends that the *FAIL SAFE MODE* setting in the (CONFIGURATION MENU) be set to *CONSTANT SETPT* if you want the BMS II to continue running the Boilers in the *CONSTANT SETPT* Mode. In this case, ensure that the *INTERNAL SETPT* (Field Adjust Menu) is set to the desired setpoint temperature.

6.4 BMS II/ACS Setup As Master To C-More Boiler Controllers

To set up the BMS II/ACS as a Master to control C-More Boiler Slaves, options must be set in the RS485 Menu as follows:

1. Using the **MENU** key on the BMS II/ACS front panel, select the RS485 MENU.
2. Scroll through the RS485 Menu and select the *RS485 BAUDRATE* option. The second line of the display will show the currently selected RS232 Baud Rate (*2400, 4800, 9600 or 19200*).
3. If *9600* is not displayed, press the **CHANGE** key.
4. Using the **▲** and **▼** arrow keys, scroll through the menu option choices until *9600* is displayed.
5. With a RS485 Baud Rate of *9600* displayed, press the **ENTER** key to store the setting in memory.
6. Continue scrolling through the RS485 MENU until *MIN SLAVE ADDR* is shown in the display.
7. If *000* is not displayed in the second line of the display, press the **CHANGE** key. Use the **▼** arrow key to set the *MIN SLAVE ADDR* to *000*.
8. Press the **ENTER** key to store the *000* address in memory.
9. Scroll through the RS485 MENU until *MAX SLAVE ADDR* is shown in the display.
10. If *000* is not displayed in the second line of the display, press the **CHANGE** key. Use the **▼** arrow key to set the *MAX SLAVE ADDR* to *000*.

CHAPTER 6: Modbus Software Setup: C-More & BMSII/ACS

11. Press the **ENTER** key to store the *000* address in memory.
12. Next, scroll to the *NUMBER OF NETW BLRS* option. The second line of the display will show the current number of Network Boilers currently stored in memory.
13. Press the **CHANGE** key and set the correct number of *NETW BOILERS*.
14. Press **ENTER** to store the number of Boilers on the Network.
15. Scroll to the *MODBUS CNTL TYPE* and ensure it is set to *ROUND ROBIN* (default). The only other setting available for this option is *BROADCAST* which is not available at this time.

NOTE:

The remaining steps in this setup procedure involve assigning separate and distinct addresses for each Boiler on the Modbus Network. The valid address range is from 001 through 127.

16. While still in the RS485 MENU, scroll to *NETW BOILER 01*. The second line of the display will show *ADDRESS = 001* which is the default address for Network Boiler 1. If desired, this address can be changed to any other value within the valid range (*001* to *127*).
17. Repeat step 16 for each additional C-More Boiler being controlled on the BMS II/ACS RS485 loop. Do Not count Boilers or Water Heaters that will only be monitored on the Modbus Network. Only count Boilers that will be controlled by the BMS II/ACS using the Modbus connection.
18. This completes programming for the BMSII/ACS RS485 Network.

The BMS II/ACS is now programmed to control the Networked Boilers. The BMS II/ACS will automatically detect any C-More Boiler that is programmed for Network Control as follows:

- Boiler Mode = Direct Drive
- Remote Signal = Network
- Comm Address = Matches one of the *NETW BOILER* addresses stored in the BMS II/ACS.

(This page intentionally blank)

APPENDIX A: C-More Reference Tables

This Appendix includes the following tables:

- C-More Controller Status & Fault Messages
- Conversion Equations
- BCM Fault Codes
- BMM Fault Codes
- I/O Status Tables

TABLE A-1: Status and Fault Messages	
STATUS MESSAGES	DESCRIPTION
FAIL SAFE MODE ACTIVATED	The system is running in the Constant Setpt mode due to loss of the Remote signal or Outdoor Air sensor input.
NETWORK DISABLED MODBUS LISTEN	“Forced Listen Only Mode” has been activated. All Modbus commands except “restart Communications Options” will be ignored. The ACS will operate in the Fail Safe Mode.
OUTSIDE AIR TEMP NOT CONNECTED	The Outdoor Air Temperature Sensor is not installed and connected.
RETURN TEMP NOT INSTALLED	The Boiler Return Temperature Sensor is not installed.
FAULT MESSAGES	DESCRIPTION
OUTDOOR SENSOR ERROR	The Outdoor Air Temperature Sensor signal is out of range.
HEADER SENSOR ERROR	The Header Temperature Sensor signal is out of range or disconnected.
RETURN SENSOR ERROR	The Return Temperature Sensor signal is out of range.
INTERLOCK 1 ERROR	Interlock 1 input is open.
INTERLOCK 2 ERROR	Interlock 2 input is open.
4 – 20 mA INPUT ERROR	The 4 – 20 mA Remote Input signal is lost.
MODBUS TIMEOUT ERROR	The Modbus remote input information was not received within the network timeout period.

APPENDIX A: C-More Status & Reference Tables

TABLE A-2: C-More Status and Fault Messages		
Code	Message	Description
1	DISABLED HH:MM pm MM/DD/YY	Displayed if ON/OFF switch is set to OFF. The display also shows the time and date that the unit was disabled.
2	STANDBY	Displayed when ON/OFF switch is in the ON position, but there is no demand for heat. The time and date are also displayed.
3	DEMAND DELAY XX sec	Displayed if Demand Delay is active.
4	PURGING XX sec	Displayed during the purge cycle during startup. The duration of the purge cycle counts up in seconds.
5	IGNITION TRIAL XX sec	Displayed during ignition trial of startup sequence. The duration of cycle counts up in seconds.
6	FLAME PROVEN	Displayed after flame has been detected for a period of 2 seconds. Initially, the flame strength is shown in %. After 5 seconds has elapsed, the time and date are shown in place of flame strength.
7	WARMUP XX sec	Displayed for 2 minutes during the initial warm-up only.
8	HIGH WATER TEMP SWITCH OPEN	The High Water Temperature Limit Switch is open.
9	LOW WATER LEVEL	The Water Level Control board is indicating low water level.
10	LOW GAS PRESSURE	The Low Gas Pressure Limit Switch is open.
11	HIGH GAS PRESSURE	The High Gas Pressure Limit Switch is open.
12	INTERLOCK OPEN	The Remote Interlock is open.
13	DELAYED INTERLOCK OPEN	The Delayed Interlock is open.
14	AIRFLOW FAULT DURING PURGE	The Blower Proof Switch opened during purge.
15	SSOV FAULT DURING PURGE	The SSOV switch opened during purge.
16	PRG SWTCH OPEN DURING PURGE	The Purge Position Limit switch on the Air/Fuel valve opened during purge.

APPENDIX A: C-More Status & Reference Tables

TABLE A-2: C-More Status and Fault Messages

Code	Message	Description
17	IGN SWTCH OPEN DURING IGNITION	The Ignition Position Limit switch on the Air/Fuel valve opened during ignition.
18	AIRFLOW FAULT DURING IGN	The Blower Proof Switch opened during ignition.
19	AIRFLOW FAULT DURING RUN	The Blower Proof Switch opened during run.
20	SSOV FAULT DURING IGN	The SSOV switch closed or failed to open during ignition.
21	SSOV FAULT DURING RUN	The SSOV switch closed for more than 15 seconds during run.
22	FLAME LOSS DURING IGN	The Flame signal was not seen during ignition or lost within 5 seconds after ignition.
23	FLAME LOSS DURING RUN	The Flame signal was lost during run.
24	HIGH EXHAUST TEMPERATURE	The High Exhaust Temperature Limit Switch is closed.
25	LOSS OF POWER	A power loss occurred. The time and date when power was restored is displayed.
26	LOSS OF SENSOR	Not Currently Used
27	LOSS OF SIGNAL	Not Currently Used
28	HIGH O2 LEVEL	Not Currently Used
29	LOW O2 LEVEL	Not Currently Used
30	HIGH CO LEVEL	Not Currently Used
31	SSOV RELAY FAILURE	A failure has been detected in one of the relays that control the SSOV.
32	RESIDUAL FLAME	The Flame signal was seen for more than 60 seconds during standby.
33	HEAT DEMAND FAILURE	The Heat Demand Relays on the Ignition board failed to activate when commanded.
34	IGN SWTCH CLOSED DURING PURGE	The Ignition Position Limit switch on the Air/Fuel valve closed during purge.
35	PRG SWTCH CLOSED DURING IGNITION	The Purge Position Limit switch on the Air/Fuel valve closed during ignition.

APPENDIX A: C-More Status & Reference Tables

TABLE A-2: C-More Status and Fault Messages

Code	Message	Description
36	SSOV SWITCH OPEN	The SSOV switch opened during standby.
37	IGNITION BOARD COMM FAULT	Communication fault between the Ignition board and the CPU board.
38	WAIT	Prompts the operator to wait.
39	DIRECT DRIVE SIGNAL FAULT	The direct drive signal is not present or is out of range.
40	REMOTE SETPT SIGNAL FAULT	The remote setpoint signal is not present or is out of range.
41	OUTDOOR TEMP SENSOR FAULT	The temperature measured by the Outdoor Air Sensor is out of range.
42	OUTLET TEMP SENSOR FAULT	The temperature measured by the Outlet Sensor is out of range.
43	FFWD TEMP SENSOR FAULT	The temperature measured by the FFWD Sensor is out of range.
44	HIGH WATER TEMPERATURE	The temperature measured by the Outlet Sensor exceeded the Temp Hi Limit setting.
45	LINE VOLTAGE OUT OF PHASE	The High AC voltage is out of phase from the low AC voltage.
46	STEPPER MOTOR FAILURE	The stepper motor failed to move the valve to the desired position.
47	SETPT LIMITING ACTIVE	Setpoint temperature has exceeded the maximum allowable setting.
48	MODBUS COMM FAULT	The RS485 (Modbus) network information is not present or is corrupted.
49	WAIT IGNITION RETRY	Second ignition trial after fault.
50	WAIT FAULT PURGE	Post purge after fault.
51	WAIT RETRY PAUSE	30 sec. pause before ignition retry.
52	EXHAUST TEMP SENSOR SHORT	Exhaust temperature sensor is shorted.
53	EXHAUST TEMP SENSOR OPEN	Exhaust temperature sensor is open.
54	WARNING EXHAUST TEMP HIGH	Exhaust temperature is close to alarm limit.

TABLE A-2: C-More Status and Fault Messages

Code	Message	Description
55	EXHAUST TEMP HIGH	Exhaust temperature has exceeded the alarm limit.
56	INLET WATER TEMP SENSOR SHORT	Inlet water temperature sensor is shorted.
57	INLET WATER TEMP SENSOR OPEN	Inlet water temperature sensor is open.
58	WARNING IN WATER TEMP HIGH	Inlet water temperature is nearing the alarm limit.
59	WARNING IN WATER TEMP LOW	Inlet water nearing freezing temperature.
60	INLET GAS PRESS SENSOR OPEN	Inlet gas pressure sensor connection input is open.
61	GAS PLATE DP SENSOR OPEN	Gas plate differential pressure sensor input is open.
62	INLET WATER FLOW SENSOR OPEN	Inlet water flow sensor input is open.
63	WARNING IN WTR FLOW LOW	Inlet water flow is too low.
64	INLET WATER HIGH FLOW	Inlet water flow is too high.

APPENDIX A: C-More Status & Reference Tables

TABLE A-3: Conversion Equations for Temperature Variables – Variable Counts to Temp		
REGISTER VARIABLE TYPE	DEGREES FAHRENHEIT (°F)	DEGREES CELSIUS (°C)
DEGREES_1	$\text{Temp}(F) = \left[\frac{(\text{RegVar}) * (230) + 500}{1000} \right] + 20$	$\text{Temp}(C) = \left[\frac{(\text{RegVar}) * (128) + 500}{1000} \right] - 7$
DEGREES_2	$\text{Temp}(F) = \left[\frac{(\text{RegVar}) * (330) + 500}{1000} \right] - 80$	$\text{Temp}(C) = \left[\frac{(\text{RegVar}) * (183) + 500}{1000} \right] - 62$
DEGREES_3	$\text{Temp}(F) = \left[\frac{(\text{RegVar}) * (520) + 500}{1000} \right] + 40$	$\text{Temp}(C) = \left[\frac{(\text{RegVar}) * (289) + 500}{1000} \right] - 4$
ABS_DEG_1	For (RegVar ≥ 0): $\text{Temp}(F) = \left[\frac{(\text{RegVar}) * (230) + 500}{1000} \right]$ For (RegVar < 0): $\text{Temp}(F) = \left[\frac{(\text{RegVar}) * (230) - 500}{1000} \right]$	For (RegVar ≥ 0): $\text{Temp}(C) = \left[\frac{(\text{RegVar}) * (128) + 500}{1000} \right]$ For (RegVar < 0): $\text{Temp}(C) = \left[\frac{(\text{RegVar}) * (128) - 500}{1000} \right]$

TABLE A-4: Conversion Equations for Temperature Variables – Temp to Variable Counts		
REGISTER VARIABLE TYPE	DEGREES FAHRENHEIT (°F)	DEGREES CELSIUS (°C)
DEGREES_1	$\text{RegVar} = \left[\frac{(\text{degF} - 20) * (1000) + 115}{230} \right]$	$\text{RegVar} = \left[\frac{(\text{degC} + 7) * (1000) + 64}{128} \right]$
DEGREES_2	$\text{RegVar} = \left[\frac{(\text{degF} + 80) * (1000) + 165}{330} \right]$	$\text{RegVar} = \left[\frac{(\text{degC} + 62) * (1000) + 91.5}{183} \right]$
DEGREES_3	$\text{RegVar} = \left[\frac{(\text{degF} - 40) * (1000) + 260}{520} \right]$	$\text{RegVar} = \left[\frac{(\text{degC} - 4) * (1000) + 144.5}{289} \right]$
ABS_DEG_1	For (degF ≥ 0): $\text{RegVar} = \left[\frac{(\text{degF}) * (1000) + 115}{230} \right]$ For (degF < 0): $\text{RegVar} = \left[\frac{(\text{degF}) * (1000) - 115}{230} \right]$	For (degC ≥ 0): $\text{RegVar} = \left[\frac{(\text{degC}) * (1000) + 64}{128} \right]$ For (degC < 0): $\text{RegVar} = \left[\frac{(\text{degC}) * (1000) - 64}{128} \right]$

APPENDIX A: C-More Status & Reference Tables

TABLE A-5: BCM (Boiler Communication Module) Fault Codes				
CODE	DESCRIPTION	EFFECT	CORRECTION	RESET
17	Boiler Pipe is frozen. FlowSensor temp. is 36°F or less.	Ignition is inhibited. Pump runs for 5 min at max speed.	Carefully defrost boiler	AUTOMATIC - when FlowSensor is greater than 41°F.
18	Maximum Δ-temperature protection. Flow temperature - Return Temperature > Water Δ-Temp Protection + 50°F	All burners turned OFF and Pump ON at maximum speed.	Check the system installation.	AUTOMATIC - when Δ-temperature < Water Δ-Temp Protection.
19	High outlet temperature. FlowSensor temperature > 203°F.	All burners turned OFF and Pump ON at maximum speed.	Check Flow Sensor or system pump	AUTOMATIC - when FlowSensor < 176°F.
38	Settings Corrupted	Ignition is inhibited. Pump runs for 5 min at max speed.	Re-program the settings. Contact Factory	MANUAL - push reset switch or cycle power.
50	Internal Failure	Ignition is inhibited.	Contact Factory for new BCM.	MANUAL - cycle the power.
58	FlowSensor fault.	All burners turned OFF.	Check flow sensor or wiring.	AUTOMATIC
97	Standby. No remote control detected and Request input is open.	Ignition is inhibited.	Close Request input for Manual operation.	MANUAL - push reset switch or cycle power.
98	No BMM detected.	Ignition is not possible.	Check the BMM eBus wiring.	MANUAL - push reset switch or cycle power.

APPENDIX A: C-More Status & Reference Tables

TABLE A-6: BMM (Burner Management Module) Fault Codes				
CODE	DESCRIPTION	EFFECT	CORRECTION	RESET
1	High Limit (STB) Thermostat activated	All burners turned OFF and Pump ON at maximum speed.	Check FlowSensor thermal connection to boiler.	MANUAL - push reset switch when temperature goes below limit.
2	Low Gas Pressure	All burners turned OFF	Check gas pressure or gas pressure switch.	AUTOMATIC - when gas pressure switch closes.
4	No flame detected at burner start	Burner control lockout.	Check flame rod or combustion.	MANUAL - push reset switch or cycle power.
5	Flame loss during run.	Ignition retry.	Check combustion and wiring.	MANUAL - push reset switch or cycle power.
6	High outlet temperature. FlowSensor temperature > 203°F.	All burners turned OFF and Pump ON at maximum speed.	Check Flow Sensor or system pump	AUTOMATIC - when FlowSensor < 176°F.
10	Internal Failure	Ignition is inhibited.	Contact Factory for new BCM.	MANUAL - cycle the power.
11	Flame signal detected before ignition.	Ignition is inhibited.	Disconnect flame rod wire from BMM. If problem goes away change flame rod and/or wire. If problem does not go away change BMM.	MANUAL - push reset switch or cycle power
12	FlowSensor fault	All burners turned OFF.	Check flow sensor or wiring.	AUTOMATIC
13	Aux Sensor fault	The boiler will operate from the FlowSensor without the AuxSensor	Check aux sensor or wiring.	AUTOMATIC
14	Return Sensor fault	All burners turned OFF.	Check return sensor or wiring.	AUTOMATIC

APPENDIX A: C-More Status & Reference Tables

TABLE A-6: BMM (Burner Management Module) Fault Codes

CODE	DESCRIPTION	EFFECT	CORRECTION	RESET
15	Maximum Δ -temperature protection. Flow temperature - Return Temperature > Water Δ -Temp Protection + 50°F	All burners turned OFF and Pump ON at maximum speed	Check the system installation.	AUTOMATIC - when Δ -temperature < Water Δ -Temp Protection
16	Boiler Pipe is frozen. FlowSensor temperature is 36°F or less.	Ignition is inhibited. Pump runs for 5 min at max speed.	Carefully defrost boiler	AUTOMATIC - when FlowSensor is greater than 41°F.
20	Flame signal detected after burner is OFF.	Ignition is inhibited.	Disconnect gas valve wire from BMM. If failure goes away, check wiring or change BMM. If failure remains check or change gas valve.	MANUAL - push reset switch or cycle power.
22	No air flow at burner after fan started for 30 seconds.	Ignition retry after 60 second delay and failure remains until we have a successful burner operation.	If fan is stopped, check supply voltage and fan wiring. If OK try another fan. If still not working change the BMM. If fan is not stopped, check the exhaust gas outlet for blockage. If OK then check the air pressure switch wiring. If still not working try another air pressure switch. If still not working, change the BMM.	AUTOMATIC/MANUAL
23	The air pressure switch doesn't switch off.	Ignition is inhibited.	Disconnect the air proving switch. If problem goes away install a new switch. If not, check the wiring. If wiring OK then change BMM.	AUTOMATIC

APPENDIX A: C-More Status & Reference Tables

TABLE A-6: BMM (Burner Management Module) Fault Codes				
CODE	DESCRIPTION	EFFECT	CORRECTION	RESET
24	Fan speed out of control: It doesn't reach pre-purge speed within 30 seconds.	Ignition retry after 60 second delay and failure remains until we have a successful burner operation.	Check fan wiring.	AUTOMATIC/MANUAL
26	Fan speed out of control: It doesn't stop within 30 seconds after turned OFF.	Ignition is inhibited.	Check fan wiring.	AUTOMATIC
27	Air flow failure during ignition.	Restart pre-purge timer. The failure remains until we have a successful burner operation.	Check fan and wiring. Check air proving switch and wiring.	AUTOMATIC
30	Settings Corrupted	Ignition is inhibited. Pump runs for 5 min at max speed.	Re-program the settings. Contact Factory	MANUAL - cycle the power or send reset message.
32	Line voltage too low. (<96 VAC)	Wait for proper line voltage. (>102 VAC)	Check input voltage else try another BMM.	AUTOMATIC
40	Low Water Flow. Low water flow switch activated.	Burners turned OFF.	Check water flow or check switch.	AUTOMATIC

APPENDIX A: C-More Status & Reference Tables

TABLE A-7: I/O Status (MSD = Most Significant Digit; LSD = Least Significant Digit)

I/O STATUS	(MSD Bit 3)	INTER-LOCK (MSD Bit 2)	INTER-LOCK 2 (MSD Bit 1)	SETBACK (MSD Bit 0)	(LSD Bit 3)	SYS STRT RELAY (LSD Bit 2)	FAULT RELAY (LSD Bit 1)	AUX RELAY (LSD Bit 0)
00	N/A	OFF	OFF	OFF	N/A	OFF	OFF	OFF
01	N/A	OFF	OFF	OFF	N/A	OFF	OFF	ON
02	N/A	OFF	OFF	OFF	N/A	OFF	ON	OFF
03	N/A	OFF	OFF	OFF	N/A	OFF	ON	ON
04	N/A	OFF	OFF	OFF	N/A	ON	OFF	OFF
05	N/A	OFF	OFF	OFF	N/A	ON	OFF	ON
06	N/A	OFF	OFF	OFF	N/A	ON	ON	OFF
07	N/A	OFF	OFF	OFF	N/A	ON	ON	ON
08 - 09	N/A	N/A	N/A	N/A	N/A	N/A	N/A	N/A
10	N/A	OFF	OFF	ON	N/A	OFF	OFF	OFF
11	N/A	OFF	OFF	ON	N/A	OFF	OFF	ON
12	N/A	OFF	OFF	ON	N/A	OFF	ON	OFF
13	N/A	OFF	OFF	ON	N/A	OFF	ON	ON
14	N/A	OFF	OFF	ON	N/A	ON	OFF	OFF
15	N/A	OFF	OFF	ON	N/A	ON	OFF	ON
16	N/A	OFF	OFF	ON	N/A	ON	ON	OFF
17	N/A	OFF	OFF	ON	N/A	ON	ON	ON
18 - 19	N/A	N/A	N/A	N/A	N/A	N/A	N/A	N/A
20	N/A	OFF	ON	OFF	N/A	OFF	OFF	OFF
21	N/A	OFF	ON	OFF	N/A	OFF	OFF	ON
22	N/A	OFF	ON	OFF	N/A	OFF	ON	OFF
23	N/A	OFF	ON	OFF	N/A	OFF	ON	ON
24	N/A	OFF	ON	OFF	N/A	ON	OFF	OFF
25	N/A	OFF	ON	OFF	N/A	ON	OFF	ON
26	N/A	OFF	ON	OFF	N/A	ON	ON	OFF
27	N/A	OFF	ON	OFF	N/A	ON	ON	ON
28 - 29	N/A	N/A	N/A	N/A	N/A	N/A	N/A	N/A
30	N/A	OFF	ON	ON	N/A	OFF	OFF	OFF
31	N/A	OFF	ON	ON	N/A	OFF	OFF	ON
32	N/A	OFF	ON	ON	N/A	OFF	ON	OFF
33	N/A	OFF	ON	ON	N/A	OFF	ON	ON
34	N/A	OFF	ON	ON	N/A	ON	OFF	OFF
35	N/A	OFF	ON	ON	N/A	ON	OFF	ON

APPENDIX A: C-More Status & Reference Tables

TABLE A-7: I/O Status (MSD = Most Significant Digit; LSD = Least Significant Digit)

I/O STATUS	(MSD Bit 3)	INTER-LOCK (MSD Bit 2)	INTER-LOCK 2 (MSD Bit 1)	SETBACK (MSD Bit 0)	(LSD Bit 3)	SYS STRT RELAY (LSD Bit 2)	FAULT RELAY (LSD Bit 1)	AUX RELAY (LSD Bit 0)
36	N/A	OFF	ON	ON	N/A	ON	ON	OFF
37	N/A	OFF	ON	ON	N/A	ON	ON	ON
38 - 39	N/A	N/A	N/A	N/A	N/A	N/A	N/A	N/A
40	N/A	ON	OFF	OFF	N/A	OFF	OFF	OFF
41	N/A	ON	OFF	OFF	N/A	OFF	OFF	ON
42	N/A	ON	OFF	OFF	N/A	OFF	ON	OFF
43	N/A	ON	OFF	OFF	N/A	OFF	ON	ON
44	N/A	ON	OFF	OFF	N/A	ON	OFF	OFF
45	N/A	ON	OFF	OFF	N/A	ON	OFF	ON
46	N/A	ON	OFF	OFF	N/A	ON	ON	OFF
47	N/A	ON	OFF	OFF	N/A	ON	ON	ON
48 - 49	N/A	N/A	N/A	N/A	N/A	N/A	N/A	N/A
50	N/A	ON	OFF	ON	N/A	OFF	OFF	OFF
51	N/A	ON	OFF	ON	N/A	OFF	OFF	ON
52	N/A	ON	OFF	ON	N/A	OFF	ON	OFF
53	N/A	ON	OFF	ON	N/A	OFF	ON	ON
54	N/A	ON	OFF	ON	N/A	ON	OFF	OFF
55	N/A	ON	OFF	ON	N/A	ON	OFF	ON
56	N/A	ON	OFF	ON	N/A	ON	ON	OFF
57	N/A	ON	OFF	ON	N/A	ON	ON	ON
58 - 59	N/A	N/A	N/A	N/A	N/A	N/A	N/A	N/A
60	N/A	ON	ON	OFF	N/A	OFF	OFF	OFF
61	N/A	ON	ON	OFF	N/A	OFF	OFF	ON
62	N/A	ON	ON	OFF	N/A	OFF	ON	OFF
63	N/A	ON	ON	OFF	N/A	OFF	ON	ON
64	N/A	ON	ON	OFF	N/A	ON	OFF	OFF
65	N/A	ON	ON	OFF	N/A	ON	OFF	ON
66	N/A	ON	ON	OFF	N/A	ON	ON	OFF
67	N/A	ON	ON	OFF	N/A	ON	ON	ON
68 - 69	N/A	N/A	N/A	N/A	N/A	N/A	N/A	N/A
70	N/A	ON	ON	ON	N/A	OFF	OFF	OFF
71	N/A	ON	ON	ON	N/A	OFF	OFF	ON
72	N/A	ON	ON	ON	N/A	OFF	ON	OFF

TABLE A-7: I/O Status (MSD = Most Significant Digit; LSD = Least Significant Digit)

I/O STATUS	(MSD Bit 3)	INTER-LOCK (MSD Bit 2)	INTER-LOCK 2 (MSD Bit 1)	SETBACK (MSD Bit 0)	(LSD Bit 3)	SYS STRT RELAY (LSD Bit 2)	FAULT RELAY (LSD Bit 1)	AUX RELAY (LSD Bit 0)
73	N/A	ON	ON	ON	N/A	OFF	ON	ON
74	N/A	ON	ON	ON	N/A	ON	OFF	OFF
75	N/A	ON	ON	ON	N/A	ON	OFF	ON
76	N/A	ON	ON	ON	N/A	ON	ON	OFF
77	N/A	ON	ON	ON	N/A	ON	ON	ON
78 - 79	N/A	N/A	N/A	N/A	N/A	N/A	N/A	N/A



© AERCO International, Inc., 2026