

<b>MATERIALS OF CONSTRUCTION</b>
HEAT EXCHANGER: 316 (Ti)
<b>HEAT EXCHANGER DESIGN STANDARDS</b>
MAX. WORKING PRESS. (PSIG): 160
MAXIMUM TEMP. (°F): 210
TEST PRESS. (PSIG): 240
<b>BOILER/WATER HEATER UNITS:</b>
ASME B & PV CODE SECTION IV STAMP H
<b>OPTIONAL:</b>
ASME B & PV CODE SECTION IV STAMP HLW (ONLY BY REQUEST FOR WATER HEATER UNITS)

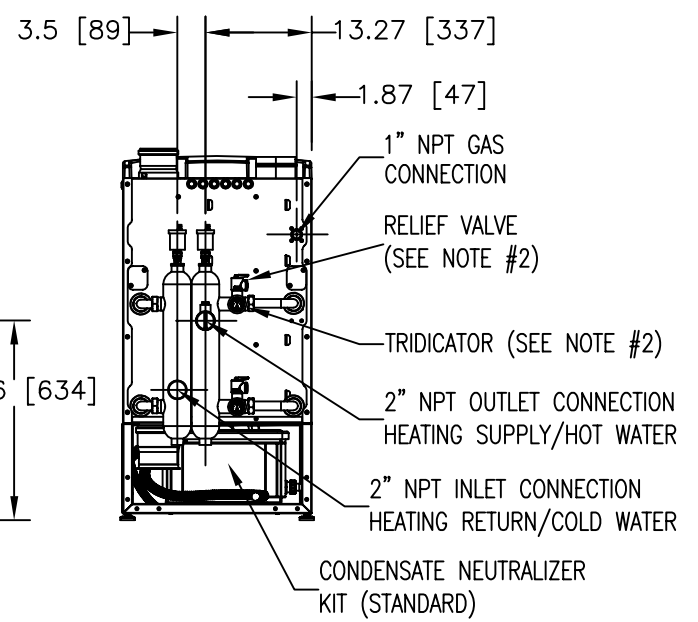
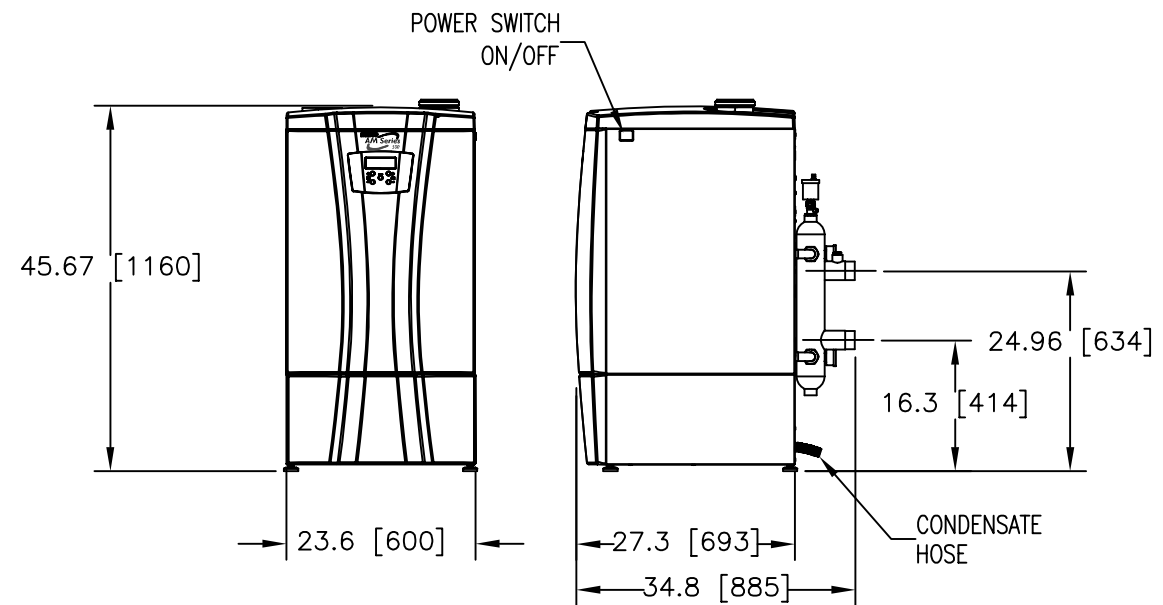
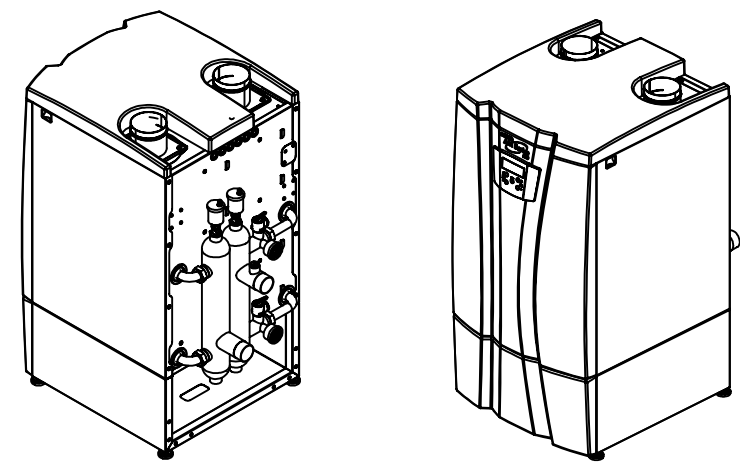
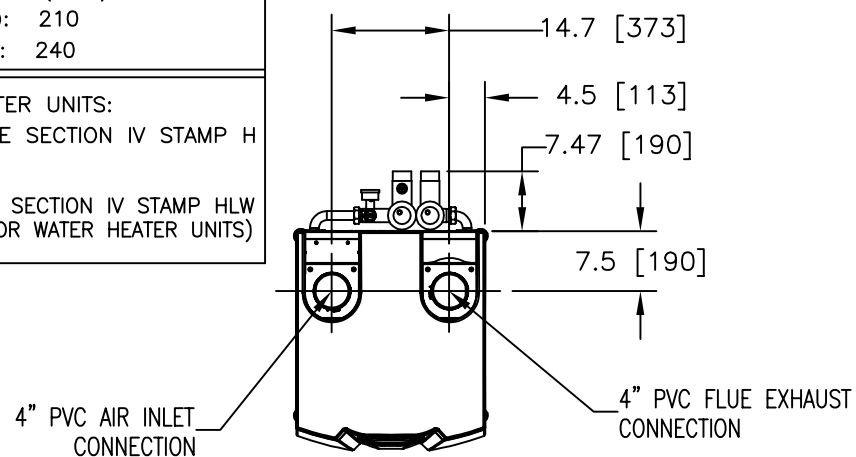

NOTES:  
 1) ALL DIMENSIONS SHOWN ARE IN INCHES (MILLIMETERS).  
 2) RELIEF VALVE AND TRIDICATOR ARE INCLUDED ONE SET ON EACH MODULE.

<b>AERCO INTERNATIONAL, INC.</b> Blauvelt, NY 10913	
AM MODELS 399 & 500 GAS FIRED BOILER/WATER HEATER DIMENSIONAL DRAWING	
DWN.BY <u>K.S.</u> DATE <u>122713</u> SCALE _____ SIZE <u>A</u> CHKD. _____ APPD. _____ REV.DATE <u>K.S. 050515</u>	AP-A-942      REV. C