

Application Guide

Modulex EXT Series

Modulating Condensing Hot Water Boilers

LIGHT COMMERCIAL MODELS:

- MLX EXT 450 2S
- MLX EXT 600 2S
- MLX EXT 800 2S
- MLX EXT 1100 2S

COMMERCIAL MODELS:

- MLX EXT 1500 2S
- MLX EXT 2300 2S
- MLX EXT 2600 2S
- MLX EXT 3000 2S

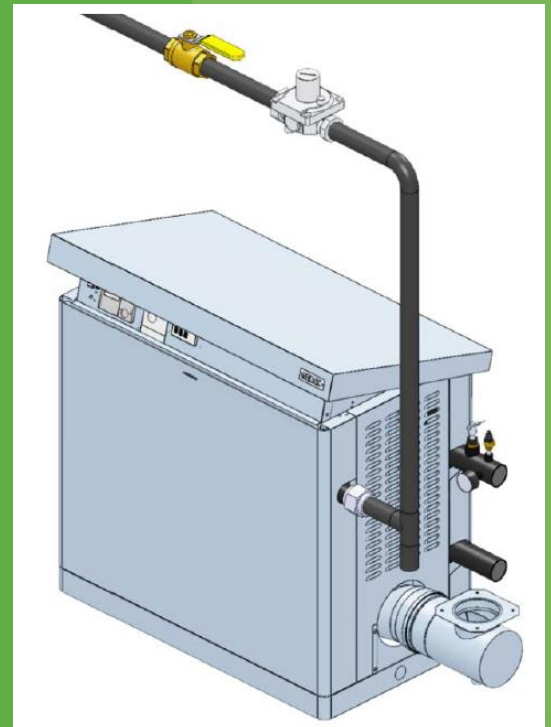

Disclaimer

The information contained in this manual is subject to change without notice from AERCO International, Inc. AERCO makes no warranty of any kind with respect to this material, including, but not limited to, implied warranties of merchantability and fitness for a particular application. AERCO International is not liable for errors appearing in this manual or for incidental or consequential damages occurring in connection with the furnishing, performance, or use of these materials.

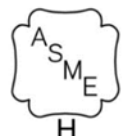

Heating and Hot Water Solutions

AERCO International, Inc. • 100 Oritani Drive • Blauvelt, NY 10913
USA: T: (845) 580-8000 • Toll Free: (800) 526-0288 • AERCO.com
Technical Support • (800) 526-0288 • Mon-Fri, 8 am - 5 pm EST
© 2021 AERCO

1. GENERAL INTRODUCTION

AERCO Modulex EXT gas fired boilers are modulating input boilers that require an adequate volume and pressure of natural or propane gas for proper operation. The gas requirements specified herein must be satisfied for efficient combustion. Designers and installers must adhere to the specifications of AERCO and of the local authorities having jurisdiction. A thorough understanding and knowledge of these guidelines is required for the successful design and installation of Modulex EXT boilers.

2. GAS TRAIN COMPONENTS

The Modulex EXT is a cast aluminum body boiler consisting of mutually connected combustion chambers, each having its own gas train (gas valve, pre-combustion chamber, and burner), blower, air pressure switch, check valve, igniter, and flame detector. Each group of these components is referred to as a module. The gas train components have been designed to operate at high combustion and seasonal efficiencies by closely controlling both the volume and air/fuel mixture to the burner. Below are descriptions of each of the gas train components for each module.

- **GAS VALVE** – An electronic, modulating gas valve with 100% tight shutoff. It controls the amount of gas delivered to the burner.
- **PRE-COMBUSTION CHAMBER** – A plastic chamber mounted to the blower, where combustion air and gas mix prior to entering the burner, providing controlled combustion. The outlet of the chamber leads to a check valve, which prevents any backflow of combustion gases.
- **LOW NO_x BURNER** – A metal fiber mesh covering a stainless steel burner head on which combustion occurs. The burner operation is stable throughout the entire input range of the boiler.

NOTE: The optimum gas pressure for the Modulex EXT boiler is 7.0" W.C. However, the Modulex EXT boiler can be safely operated at pressures ranging from 3.5" W.C. to 10.5" W.C.

3. GAS PRESSURE REQUIREMENTS

AERCO Modulex EXT boilers require a stable gas input pressure. The inlet supply to the unit must be *at least* 3.5" W.C. when firing at maximum input. A minimum supply gas pressure switch prevents the boiler from operating without sufficient pressure. Maximum allowable gas pressure is 10.5" W.C. Static gas pressure (when the unit is not firing) may vary, however actual gas pressure should be measured when the unit is in operation (firing). Measure the gas pressure with a manometer at the port provided in the inlet manifold. In a multiple boiler installation, gas pressure should initially be set for a single boiler in operation and then remaining boilers should be staged on at full fire to ensure that gas pressures never fall below the minimum allowable pressure of 3.5" W.C.

An external gas pressure regulator is mandatory for the State of Massachusetts, regardless of supply pressure; for all other jurisdictions, a lock-up style regulator is required when supply pressure is greater than 10.5" W.C. (see Fig. 1). The regulator must be installed with at least 2 feet of pipe between the regulator and the unit gas inlet. The regulator discharge range must be able to maintain 3.5" W.C. Gas regulators are self-contained with tapped diaphragm vent ports allowing the diaphragm to change its position. These vents typically require piping to the outside.

Every Modulex boiler requires a manual shutoff valve. CSA requires that no other components can be installed between the boiler and this shutoff valve except for pipe fittings such as a pipe union. If an external regulator is used, an additional isolation/service valve must be installed upstream of the regulator (see **Figure 1**). Gas piping should contain ground unions for removal of the gas piping to the unit for maintenance or service as required. Gas piping should never obstruct removal of the unit side panels and should not be supported from the unit itself. Gas piping should be supported properly from the floor or overhead as the installation allows.

CAUTION!

The AERCO Modulex EXT boilers must be isolated from the system when leak testing.

Drip legs are typically required at the gas supply of each unit to prevent any dirt, weld slag, or debris from entering the boiler gas train inlet pipe. When multiple units are installed, some utilities and local codes require a full size drip leg on the main gas supply line in addition to the drip leg at each unit. The bottom of the gas drip leg(s) should be removable without disassembling any gas piping. The weight of the gas pipe should not be supported from the bottom of the drip leg. The drip leg(s) should not be used to support any or part of the gas piping.

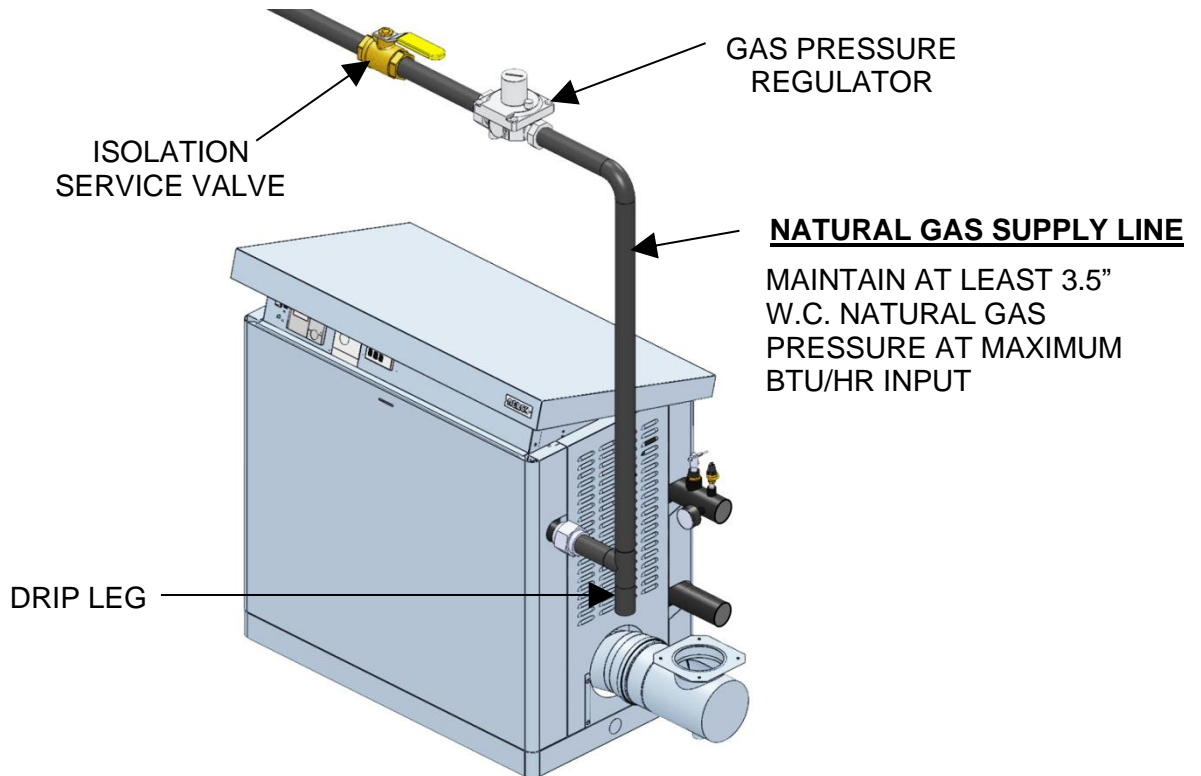

Figure 1: Single Boiler Gas Pipe Connections

4. GAS PIPING

All gas piping and components must comply with NFPA local codes, and utility requirement minimums. Only gas approved fittings, valves, or pipe should be utilized.

Standard industry practice for gas piping is Schedule 40 iron pipe and fittings. All high and low gas pressure piping systems must comply with local utility and building codes.

Assembled piping should be clean of all debris, pipe chips, or foreign material to prevent any from entering the Modulex boiler gas trains. Piping should be tested as prescribed in NFPA 54. Equipment should be isolated before testing any piping system over the allowable pressure. **DO NOT EXCEED 10.5" W. C.** on the inlet side of the Modulex boiler at any time.

5. GAS SUPPLY MAIN SIZING

The fuel supplier, or utility, should be consulted to confirm that sufficient volume and normal pressure is provided to the building at the discharge side of the gas meter or supply pipe. For existing installations with gas equipment, gas pressure should be measured with a manometer to ensure sufficient pressure is available. Before sizing gas piping, a survey of all connected gas devices should be made. Gas piping supplying more than one gas device must be able to handle the total connected input within the allowable gas pressure drop. The allowable minimum and maximum gas pressure for each device should be considered. Whenever the minimum and maximum gas pressures vary between devices, gas pressure regulators at each unit should be installed to allow regulation at any individual unit. Gas pressure must never exceed the maximum allowable rating of any connected device.

The total length of gas piping as well as fitting pressure drop must be considered when sizing the gas piping. Total equivalent length should be calculated from the meter or source location to the last unit connected. Gas piping **Table 1**, containing data extracted from NFPA 54, should be used as a *minimum guideline*. Gas pipe size should be selected on the total *equivalent* length from the table. The gas volume for cfh flow will be the input divided by the calorific value of the fuel to be supplied.

TABLE 1: Gas Supply Main Piping Minimum Size Requirements							
Nominal Iron Pipe Size	Maximum Capacity of Pipe in Cubic Feet of Gas / Hour (Gas pressure = 0.5 psig or less, pressure drop = 0.5 inches of W.C.) (Natural Gas with Specific Gravity of 0.60)						
	Length of pipe in feet						
	10'	20'	30'	40'	60'	80'	100'
1.1/4"	1,390	957	768	657	528	452	400
1.1/2"	2,090	1,430	1,150	985	791	677	600
2"	4,020	2,760	2,220	1,900	1,520	1,300	1,160
2.1/2"	6,400	4,400	3,530	3,020	2,430	2,080	1,840
3"	11,300	7,780	6,250	5,350	4,290	3,670	3,260
4"	23,100	15,900	12,700	10,900	8,760	7,490	6,640
5"	41,800	28,700	23,000	19,700	15,800	13,600	12,000

NOTE: For further information refer to National Fuel Gas Code Handbook, ANSI Z223.1.

6. GAS HEADER SIZING

Main supply gas pipe sizing should be developed for the total plant. Boiler gas manifold piping should be sized based on the volume requirements and lengths between boilers and the fuel main. Header sizes can be either full size or stepped in size as units are connected. A typical gas piping header diagram for two AERCO Modulex boilers is illustrated in **Figure 2**. Header should be located above or behind boiler. Gas piping should not be installed directly over top or front of any part of boiler.

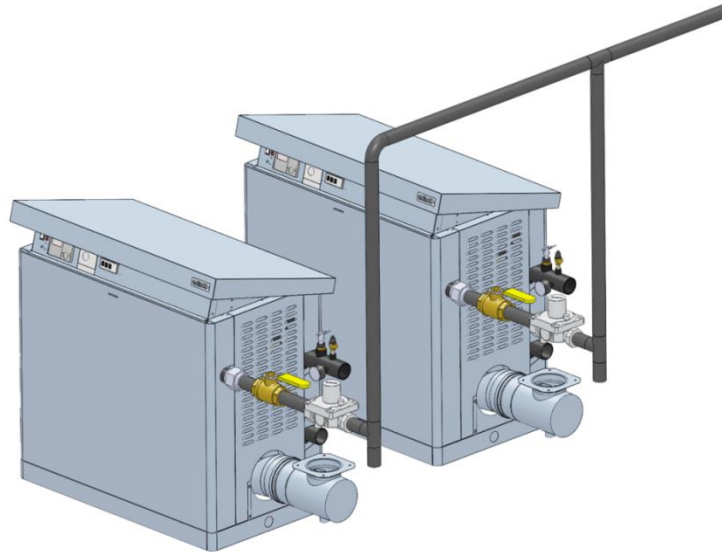

Figure 2: Typical Multiple Boiler Gas Manifold Construction

Ensure proper clearances for maintenance. Piping should not interfere with the removal of the unit's sheet metal nor impede maintenance. Observe service clearances around the boiler as listed below and as shown in Figures 3, 4, and 5:

EXT 450 2S, 600 2S, 800 2S and 1100 2S

- TOP of the boiler: 24" (600 mm)
- FRONT of the boiler: 24" (600 mm)
- RIGHT side: 24" (600 mm)
- LEFT side: 24" (600 mm)
- FLOOR/GROUND: 4" (100 mm)
- BACK of the boiler: 24" (600 mm)

EXT 1500 2S, 2300 2S, 2600 2S and 3000 2S

- TOP of the boiler: 24" (600 mm)
- FRONT of the boiler: 24" (600 mm)
- Exhaust vent side: 32" (600 mm)
- All non-vented sides: 24" (600 mm)
- FLOOR/GROUND: 4" (100 mm)

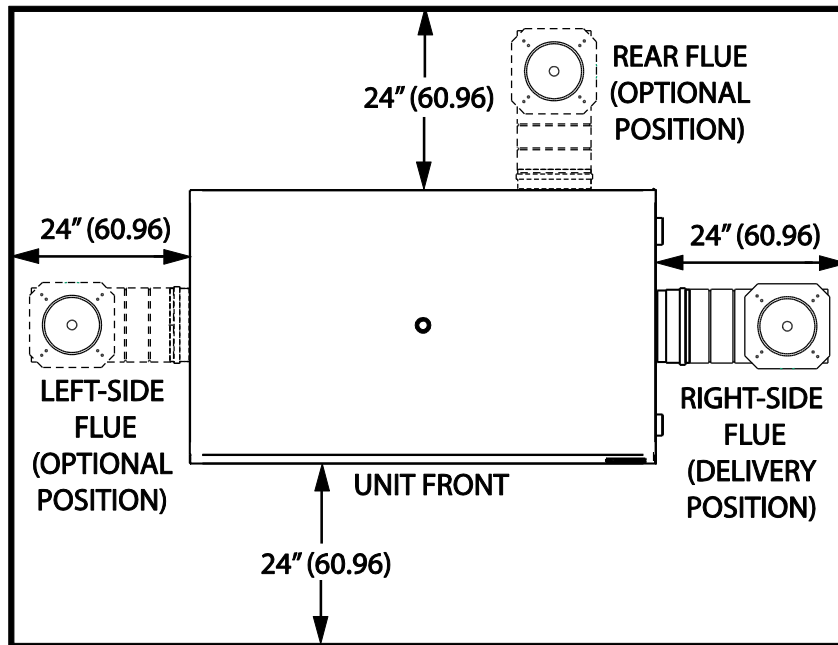

Figure 3: *MODULEX EXT 450 2S-1100 2S Boiler Clearances*

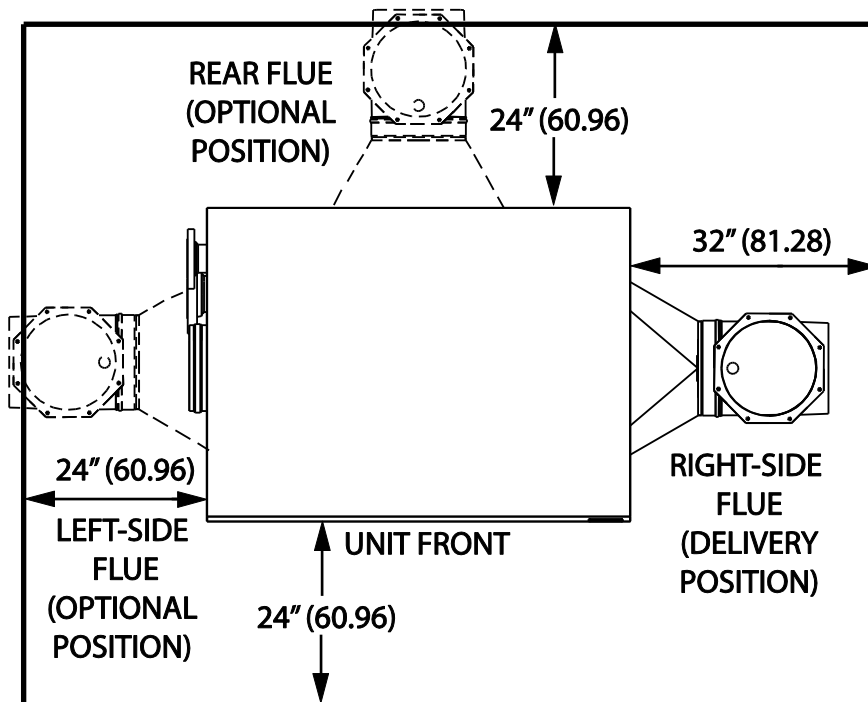

Figure 4: *MODULEX EXT 1500 2S-3000 2S Boiler Clearances*

NOTE: Standard locations for components/connections are on the right hand side. Dotted lines show alternate flue locations.

For EXT 1500 2S-3000 2S (Figure 4), use 32" (81.28mm) for vent flue at any side as needed, and 24" (60.96mm) all others.

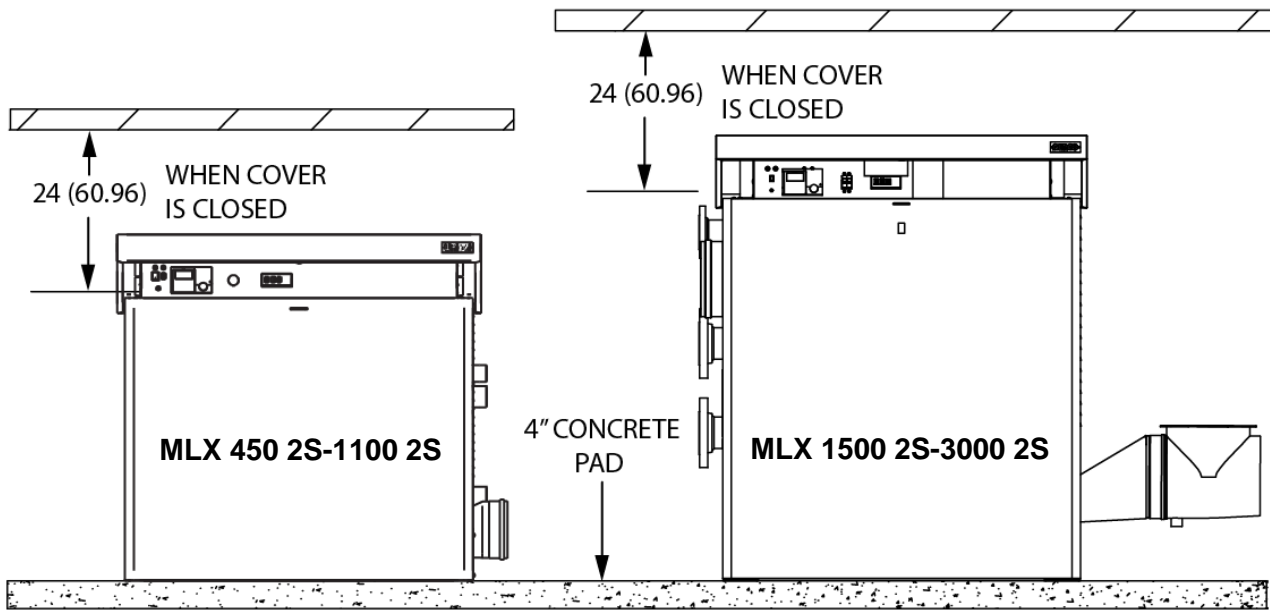

Figure 5: MODULEX EXT Boiler Top Clearances