

## Technical Data Sheet

# SmartPlate EV Double Wall Water-to-Water Heater

The newly evolved AERCO SmartPlate EV water heater is designed to satisfy potable water heating needs in commercial and institutional environments. The packaged system incorporates simple, easy to understand, real-time, load tracking and responsive controls to maintain accurate hot water temperatures under diversified load patterns.

Packaged with a PID temperature controller and a 3-way electronic control valve, the heater maintains outstanding temperature control when operated under constant load conditions with variances held to  $\pm 4^{\circ}\text{F}$  under normal load changes.\* An integrated load monitoring system and high turndown electronic control valve deliver accurate temperature control without the need for storage tanks, blending valves or other temperature averaging components. The heater can be remotely monitored and/or fully integrated with BAS software via Modbus communications protocol.

The packaged heater consists of a counter flow, stainless steel, brazed plate – the most efficient water-to-water heat exchanger design available for potable water heating. Ideal for use with condensing boilers, the SmartPlate EV heater utilizes boiler water as little as  $5^{\circ}\text{F}$  above the required potable water temperature, resulting in the highest possible boiler efficiency and minimal radiation losses. To ensure longevity, all water wetted (potable water side) parts are stainless steel or copper alloy materials.

The unit's instantaneous design is compatible with low temperature boiler water. And installation is easy because of its small footprint and doorway size. Single point header connections for domestic hot water, cold water, boiler water inlet, boiler water outlet, and electrical power supply are all that is required for a fully functional, safe, and efficient system. Tight temperature control, high thermal efficiency, low maintenance, longevity and overall reliability make the SmartPlate EV heater the most logical choice for any commercial or institutional domestic water-to-water heating installation.

The SmartPlate EV offers direct 2-way communication with AERCO Benchmark Platinum boilers for optimal control and communication. Likewise, the boiler bypass connection in the SmartPlate EV can be piped to the upper return connections of Benchmark Platinum boilers for best-in-industry efficiency. Combination heating and domestic hot water plant solutions have evolved to the next level with AERCO SmartPlate EV and Benchmark Platinum boilers.

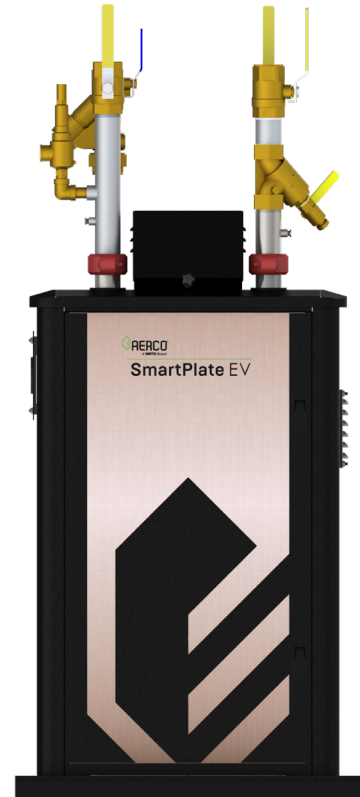

## Features

- Accurate temperature control  $\pm 4^{\circ}\text{F}$ \*
- Packaged with 3-way electronic control valve
- Fully modulating variable primary input
- Compact footprint  $< 6 \text{ ft}^2$
- All stainless steel or copper alloy wetted (potable water side) surfaces
- ASME B&PV Code Section VIII Division 1 stamped

## Supports Multiple Applications

- LTBW (2 Options); up to 150 PSIG,  $190^{\circ}\text{F}$  or 300 PSI,  $190^{\circ}\text{F}$
- DHW: up to 150 PSIG or 300 PSIG
- Set point range  $50^{\circ}\text{F}$  to  $180^{\circ}\text{F}$
- Single or multiple installations
- Supports 2-way or 3-way applications
- Ideal for new or retrofit

\*Incremental change in flow that does not exceed 50% of total capacity; i.e., demand change from 0 to 50% or 20 to 70%

# Dimensions

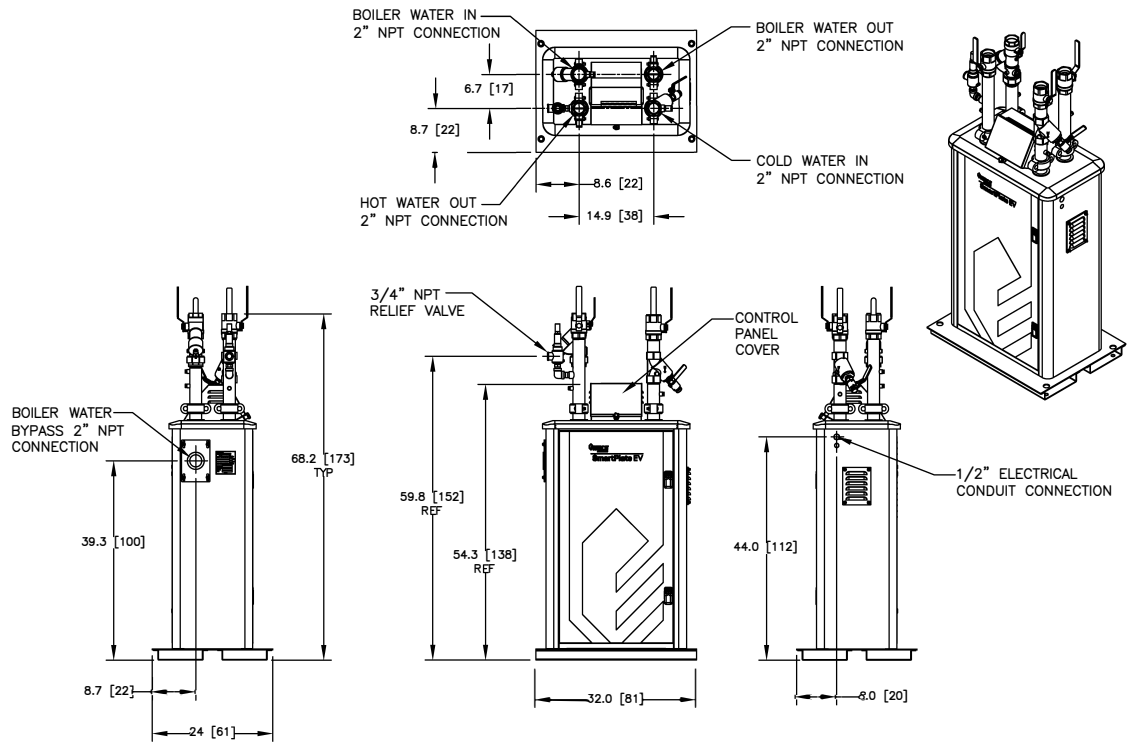

# Specifications

Domestic Water Pressure Drop	7 PSIG @ max. rated flow
Ambient Operating Temperature	23°F to 122°F
Electrical Requirements	120/1/60 Hz 2 Amp, 220/1/50 Hz 2 Amp
Standby Amperage Draw	2 Amp
High Limit "Tripped" Amperage Draw	2 Amp
Max. Continuous Water Flow Rate	90 GPM
Max. Boiler Water Pressure & Temperature	150 PSIG @ 190°F or 300 PSIG @ 190°F*
Max. Domestic Water Operating Pressure	150 PSIG or 300 PSIG*
Adjustable Temperature Control	up to 180°F
Adjustable High Limit Control	up to 200°F
Water Connection Inlets/Outlets	2" FNPT
Weight (lbs.)	SPDW-EV30 650 (dry), 670 (installed), SPDW-EV40 720 (dry), 760 (installed), SPDW-EV60 750 (dry), 800 (installed), SPDW-EV90 850 (dry), 900 (installed), SPDW-EV140 1250 (dry), 1400 (installed)

\*For SPEV140 model and 300 PSIG option, please contact your local sales representative.



Heating and Hot Water Solutions

AERCO International, Inc. • 100 Oritani Drive • Blauvelt, NY 10913  
 USA: T: (845) 580-8000 • Toll Free: (800) 526-0288 • AERCO.com